

RADIO'S LIVEST MAGAZINE



August  
25 Cents

# Radio-Craft

HUGO GERNSBACK Editor

The Radio  
Typewriter

See Page 74



The PENTODE Portable Set—A. D. C. PENTODE Receiver—Modernizing Old Radiolas  
Radio Servicing and Testing—Sound Recording—Power Amplifiers—Short-Wave Coils

# NEW **SPEED** TUBES

## FOR ALL NEW RECEIVERS

EVER ABREAST OF THE RADIO TIMES

**SPEED** adds new important types to an already complete line of receiving tubes.



235

New screen grid tube—designed to reduce cross modulation and similar distortion.

551

New screen grid tube—designed for same purpose as type 235, although having slightly different characteristics.

230

New general purpose tube, operating economically at 2 volts, giving unusual service though using very little power.

231

New amplifier using 2 volts and extremely low current consumption, in same group as types 230 and 232.

232

New screen grid tube—for use as radio frequency amplifier, operating at 2 volts.

233

New power amplifier in the Pentode group, operating on 2 volts with low current consumption.

247

New power amplifier Pentode, for use in the output stage of AC receivers.

236

New screen grid tube used mainly as R.F. amplifier or detector in automobile sets. In same group as type 237 and 238. Also for use in D.C. sets.

237

New general purpose tube—especially adapted to automobile use. Can be used either as a detector or amplifier. Also for use in D.C. sets.

238

New power amplifier Pentode for use in automobile receivers designed for it. Gives unusual volume for small input signal strength.

S 84

Developed expressly for replacement of type C 484 in Sparton sets. Somewhat similar in characteristics to the type 227.

S 82 B

Developed expressly for replacement of the C 182 B in Sparton sets, possessing all the peculiar characteristics necessary for this purpose.

S 83

Developed expressly for replacement of the C 183 in Sparton sets, possessing all the peculiar characteristics necessary for this purpose.

**SPEED** Quality is Making History Today. Write for Complete Details.

Still another addition to a big family. **SPEED** FOTO-LECTRIC TUBES. Standard gas-filled type, red sensitive, caesium on caesium-oxide silver-oxide. Six months guarantee against defects. Write for FOTO-LECTRIC booklet.



**CABLE RADIO TUBE CORPORATION**

230-240 NORTH 9th STREET, BROOKLYN, NEW YORK

**RCA**  
LICENSED



# Train *with* R.T.A. *for* Radio Service Work

Important and far-reaching developments in Radio create sudden demand for specially equipped and specially trained Radio Service Men.



*This excellent  
set analyzer  
and trouble  
shooter included  
with our course  
of training*

**M**ANY skilled Radio Service Men are needed now to service all-electric sets. By becoming a certified R. T. A. Service Man, you can make big money, full time or spare time, and fit yourself for the big-pay opportunities that Radio offers.

We will quickly give you the training you need to qualify as a Radio Service Man . . . certify you . . . furnish you with a marvelous Radio Set Analyzer. This wonder instrument, together with our training, will enable you to compete successfully with experts who have been in the radio business for years. With its help you can quickly diagnose any ailing Radio set. The training we give you will enable you to make necessary analysis and repairs.

Serving as a "radio doctor" with this Radio Set Analyzer is but one of the many easy ways by which we help you make money out of Radio. Wiring rooms for Radio, installing and servicing sets for dealers, building and installing automobile Radio sets, constructing and installing short wave receivers . . . those are a few of the other ways in which our members are cashing in on Radio.

As a member of the Radio Training Association, you receive personal instruction from skilled Radio Engineers. Upon completion of the training, they will advise you personally on any problems which arise in your work. The Association will help you make money in your spare time, increase your pay, or start you in business. The easiest, quickest, best-paying way for you to get into Radio is by joining the Radio Training Association.

This amazing Radio Set Analyzer plus the instructions given you by the Association will transform you into an expert quickly. With it, you can locate troubles in all types of sets, test circuits, measure resistance and condenser capacities, detect defective tubes. Knowing how to make repairs is easy; knowing what the trouble is requires expert knowledge and a Radio Set Analyzer. With this Radio Set Analyzer, you will be able to give expert service and make big money. Possessing this set analyzer and knowing how to use it will be but one of the benefits that will be yours as a member of the R. T. A.

## Write for No-Cost Membership Plan

We have worked out a plan whereby a membership enrollment need not cost you a cent. Our thorough training and the valuable Radio set analyzer can be yours. Write at once and find out how easily both of these can be earned.

Now is the time to prepare to be a Radio Service Man. Greater opportunities are opening up right along. For the sake of extra money in your spare time, bigger pay, a business of your own, a position with a future, get in touch with the Radio Training Association of America now.

Send for this No-Cost Membership plan and Free Radio Handbook that will open your eyes as to what Radio has in store for the ambitious man. Don't wait. Do it now.

**RADIO TRAINING ASSOCIATION OF AMERICA**  
Dept. RCA-8      4513 Ravenswood Ave.      Chicago, Ill.

Fill Out and Mail Today!

**RADIO TRAINING ASSOCIATION OF AMERICA**  
Dept. RCA-8, 4513 Ravenswood Ave., Chicago, Ill.

Gentlemen: Send me details of your No-Cost Membership Enrollment Plan and information on how to learn to make real money in radio quick.

Name .....

Address .....

City..... State.....

H. GERNSBACK, President  
 S. GERNSBACK, Treasurer  
 J. M. HERZBERG, Vice-President  
 I. S. MANHEIMER, Secretary



HUGO GERNSBACK, Editor-in-Chief

R. D. WASHBURNE,  
 Technical Editor

C. P. MASON,  
 Associate Editor

VOLUME III  
 NUMBER 2

## Contents of This Issue

AUGUST  
 1931

	PAGE		PAGE
<b>EDITORIAL:</b>		<b>RADIO CONSTRUCTION AND THEORY:</b>	
Radio and Prosperity.....By Hugo Gernsback	73	The Radio Robot (Part II).....By H. G. Cisin	77
<b>NEW DEVELOPMENTS IN RADIO:</b>		Remote Control of Radio Reception...By Eli M. Lurie	78
The Radio Typewriter.....	74	The RADIO-CRAFT "Pentode Portable".....	88
The Latest Radio Appliances.....	75	The Short-Wave Superregenerative..By Clifford E. Denton	90
Fitting One Chassis to Three Cabinets.....	76	Short-Wave Converters and Their Operation	
<b>SOUND RECORDING:</b>		By Ronald Lewis	93
Recording Equipment and Its Operation		Stenode's Selectivity is Revolutionary.....	94
By George J. Saliha	80	Replacement of Volume Controls.....By H. G. Cisin	95
<b>SERVICE MAN'S DEPARTMENT:</b>		An Ideal Sound System for High Power	
Operating Notes for Service Men..By Bertram M. Freed	82	By C. H. W. Nason	96
The Open Forum.....	83	Pentodes and Their Use.....By C. E. Denton	97
<b>RADIO SERVICE DATA SHEETS</b>		Modernizing Old Radiolas with Two-Volt Tubes	
No. 47—The Radiola "Superette" and Allied Models	84	By F. L. Sprayberry	98
No. 48—The Bosch "60".....	85	Short-Wave Inductances and How to Figure Them.....	99
Favorite Testing Equipment of Service Men.....	86	How to Work with Two-Volt Tubes..By C. A. Oldroyd	100
Service Men's Notebooks.....	87	RADIO-CRAFT'S Information Bureau.....	102

### In Forthcoming Issues

**THE RADIO-CRAFT A.C. PENTODE PORTABLE.** This little receiver, lightened of its batteries and with a screen-grid detector, gives loud-speaker volume with even distant stations, where a standard light-line is available. It will be described in the September issue of RADIO-CRAFT.

**A DIRECT-CURRENT SHORT-WAVE CONVERTER.** The super-converters hitherto described have been for A.C. or battery operation. Mr. W. E. Smith, author of the "Roll-Your-Own," has worked out a self-contained converter for operation from the D.C. light line.

**"GOING AFTER SERVICE"** by J. P. Kennedy. The writer tells how he built up a successful service business from the beginning, under the pressure of unfavorable business conditions. The story is full of suggestions which not only beginners, but well-established Service Men can put to good account.

**THE "RADIO SHERLOCK HOLMES"**—a device of remarkable ingenuity—and many other ingenious applications of radio which will intrigue the constructor, who is interested in photoelectric-cell technique, will be explained with data for their construction.

RADIO-CRAFT is published monthly, on the fifth of the month preceding that of date; its subscription price is \$2.50 per year. (In Canada and foreign countries, \$3.00 a year to cover additional postage.) Entered at the postoffice at Mt. Morris, Ill., as second-class matter under the act of March 3, 1879. Trademarks and copyrights by permission of Gernsback Publications, Inc., 98 Park Place, New York City.

Text and illustrations of this magazine are copyright and must not be reproduced without permission of the copyright owners. We are also agents for WONDER STORIES and WONDER STORIES QUARTERLY. Subscriptions to these magazines may be taken in combination with RADIO-CRAFT at reduced club rates. Write for information.

Copyright 1931, GERNSBACK PUBLICATIONS, INC.

Published by  
**TECHNI-CRAFT PUBLISHING CORPORATION**

Publication Office: 404 No. Wesley Ave., Mount Morris, Illinois

Editorial and Advertising Offices  
 96-98 Park Place, New York City

Chicago Advertising Office  
 737 North Michigan Avenue, Chicago, Ill.

Western Advertising Office  
 220 No. Catalina St., Los Angeles, Calif.

L. F. McCLURE, Chicago Advertising Representative

LOYD B. CHAPPELL, Western Advertising Representative

London Agent: Hachette & Co.,  
 3 La Belle Sauvage, Ludgate Hill, E.C. 4

Paris Agent: Hachette & Co.,  
 111 Rue Roumure

Australian Agent: McGill's Agency,  
 179 Elizabeth St., Melbourne



# A BIG PAY JOB for YOU

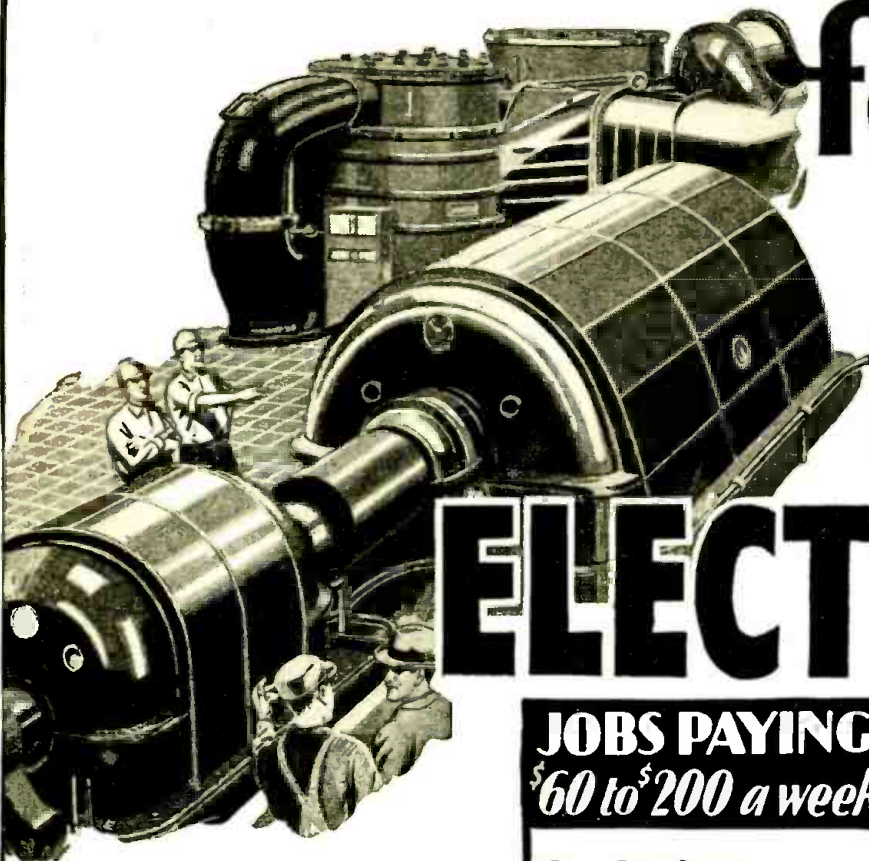

in the biggest  
money making  
game on earth

# ELECTRICITY

**JOBS PAYING**  
*\$60 to \$200 a week*

Power Plant Operator	\$.50 to \$ 70 a week
Maintenance Engineer	\$60 to \$100 a week
Armature Winding	\$.45 to \$ 75 a week
Illumination Expert	\$.50 to \$ 80 a week
Radio Service Expert	\$.50 to \$100 a week
Aviation Ignition	\$.60 to \$125 a week
Battery Expert	\$.70 to \$200 a week
Auto Electrician	\$.75 to \$200 a week
Contractor-Dealer	\$.60 to \$300 a week
Signal Engineering	\$.50 to \$100 a week

**Free Employment Service**

**Earn As You Learn**

Don't worry about a job! My Employment Department gives you a FREE life-time service. And if you need part-time work while at School to help pay expenses, we'll gladly help you get it. Don't let anything keep you out of this Big Pay field!

**Get My Big FREE Book**

Get the PROOF! Mail coupon for my Big FREE book, telling all about jobs—salaries—opportunities. Find out about my FREE Radio and Automobile Electricity offers, and my special low tuition offer. This does not obligate you.

**Just Mail the COUPON!**

Don't spend your life in a dull, hopeless job! Don't be satisfied with \$30 or \$40 a week! MAIL COUPON BELOW FOR FREE PROOF THAT YOU CAN HAVE A GOOD ELECTRICAL JOB IN 90 DAYS! Electricity pays salaries of \$60, \$70 and even \$200 a week to thousands of fellows no smarter than you.

**THOUSANDS OF JOBS ARE OPEN**

Thousands of Jobs are open, paying \$60 a week and up—in Power Plant work, Armature Winding, Auto Ignition, House Wiring, Radio Service, Refrigeration, Welding, Aviation Electricity, Illumination, etc. You can prepare for one of these Big Pay Jobs in 90 days! Mail coupon for PROOF!

## Learn Without Lessons in 90 days

Come to Coyne at Chicago and learn Electricity the quick and practical way—not by correspondence, but by actual electrical work—on huge motors and generators, switchboards, powerplants, substations, armatures, auto and airplane engines, etc. You don't need advanced education or previous experience. Coyne has been training men for Big Pay Electrical Jobs since 1899. Let Coyne help YOU to a good electrical position!

**COYNE ELECTRICAL SCHOOL**, H. C. LEWIS, Pres.  
500 S. Paulina St., Dept. C1-81, Chicago, Ill.

H. C. LEWIS, President  
Coyne Electrical School, Dept. C1-81  
500 S. Paulina Street, Chicago, Ill.

Gentlemen: Please send me your big Free Electrical Book with 151 illustrations. This does not obligate me.

Name .....

Address .....

City ..... State.....



# BIG News for you

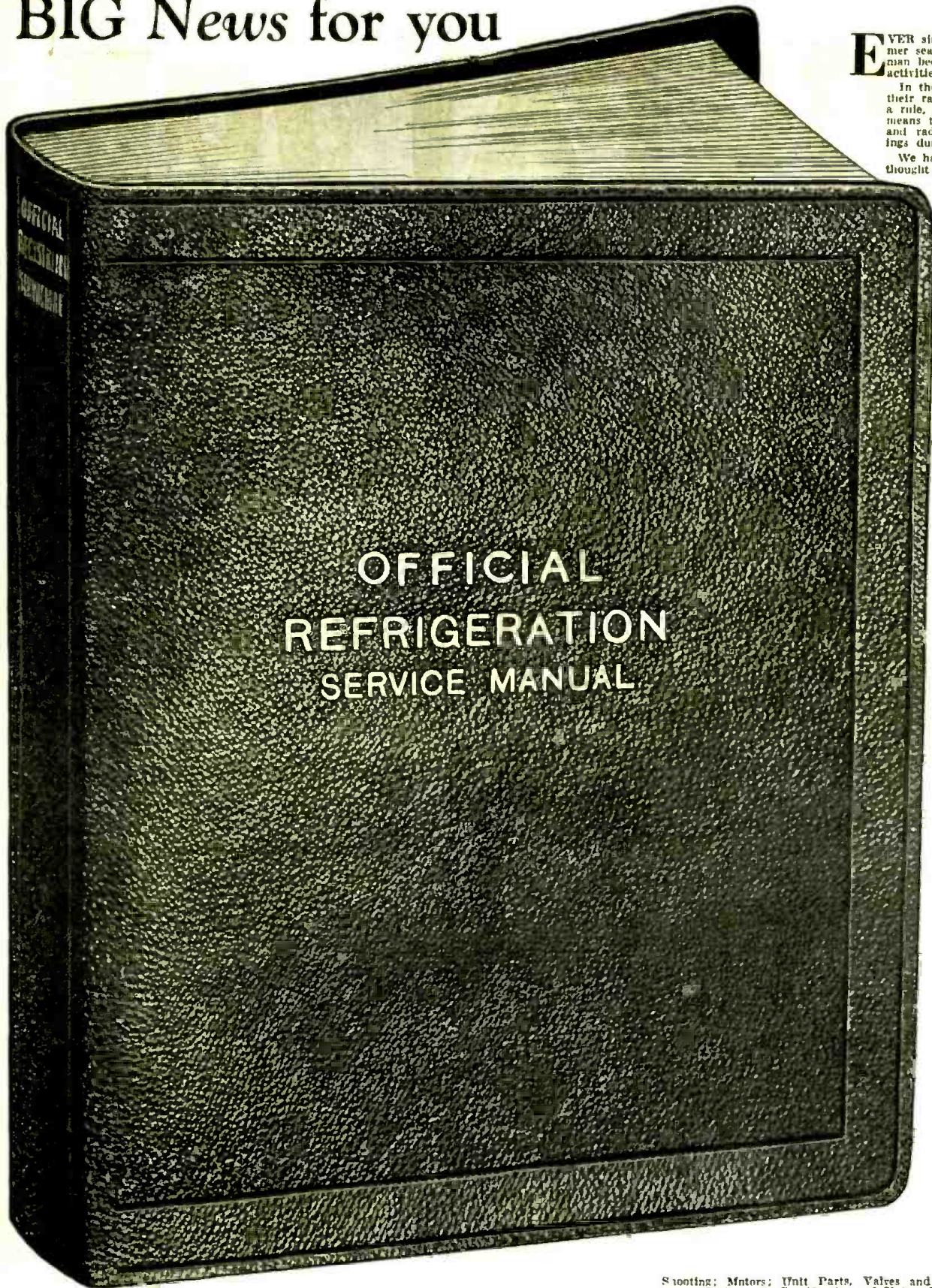

**E**VER since the advent of radio, the summer season has been a curse to the radio man because that is the time when radio activities are at their lowest.

In the summer time, people do not use their radio sets so much and there is, as a rule, little servicing to be done. This means that the average radio service man and radiotrician finds pretty slim pickings during the summer months.

We have given this problem considerable thought and for over a year worked quietly on the problem; and from now on every radio man, service man and radiotrician will have a steady income all the year around, incredible as this may seem.

The idea of radio people servicing refrigeration units is self-evident and the thought has occurred to perhaps untold thousands of radio men ever since electric refrigeration started. Yet nothing was done, because the average radio man knows little or nothing about refrigeration. Our survey of the field convinces us that, compared with servicing a radio set, the servicing of a refrigerator is absurdly simple, once you get the hang of it; and that is exactly why the **OFFICIAL REFRIGERATION SERVICE MANUAL** is going to be a side-partner to the **OFFICIAL RADIO SERVICE MANUAL**, with which you are well acquainted.

When you are called in to service a radio set, it is easy to find out if your customers own a refrigerator. If they do, you can now tell them that you can service the refrigerator as well. Place your card somewhere near the refrigerator so that, if trouble comes, you will be called in to fix it.

From whatever point you look at it, you will make money. And don't ever lose sight of the fact that refrigerators usually need servicing in the summer time and that it is here that you will get a new and extra income.

But don't take our word for all this. Study the situation yourself and see if we are not right. Look around in your locality and find out how many refrigerators there are. At the present time the servicing of these refrigerators goes to other trades when this business niche just as well belong to you.

So we say to you, why not go into the refrigeration servicing business at once? Remember, there is big money in it and the refrigeration business is growing enormously every year; and it won't be very long before there will be more refrigerators than radios.

The **OFFICIAL REFRIGERATION SERVICE MANUAL** has been edited by L. E. Wright, who is an expert and a leading refrigeration authority. He is a member of the American Society of Mechanical Engineers, American Society of Refrigeration Engineers, The National Association of Practical Refrigeration Engineers, etc.

The new Manual, as you will see from the photographic reproduction, is the same size as our **OFFICIAL RADIO SERVICE MANUAL**. It will be 9 x 12 inches, and will contain 352 pages—loose-leaf, bound in leatherette, gold-stamped cover; in fact, it is a gold mine of information on the entire art of refrigeration.

Here are the chapter contents: Preface; Introduction; History of Refrigeration; Fundamentals of Refrigeration; Description of All Known Types of Refrigeration; Service Tools and Shop Equipment; Trouble Shooting; Makes and Specifications of Units; Manufacturers of Cabinets.

Every page is profusely illustrated; every refrigerator part is explained; diagrams are furnished of every known machine; special care is given to the servicing end, of course; all the tools needed are illustrated and their use explained; there are trouble shooting charts, and other service data.

This by no means exhausts the contents of the book, and it would take much more space to give you all of the details. Last year, when we brought out the **OFFICIAL RADIO SERVICE MANUAL**, we made a special pre-publication offer to our friends, which actually saved them thousands of dollars. We are now giving you the same chance again for a very short time.

### SPECIAL PRE-PUBLICATION OFFER

The regular price of the **OFFICIAL REFRIGERATION SERVICE MANUAL** is \$5.00 after it is published. To you, the book will be sold at \$3.50 prepaid if you send in your order at once before the publication of the book. Please use the coupon. The whole book is now ready for the printers and we are putting on the last finishing touches. It will be in the printer's hands in a few weeks. Once the **OFFICIAL REFRIGERATION SERVICE MANUAL** is issued, you know from experience that we cannot allow any price reduction and, the instant the book comes off the press, the price will be \$5.00.

**GERNSBACK PUBLICATIONS, Inc.**

96-98 Park Place

New York, N. Y.

GERNSBACK PUBLICATIONS, Inc.  
96-98 Park Place, New York, N. Y.

RC-3

As per your special pre-publication offer, I enclose herewith my remittance for \$3.50 (check or money order preferred) for which you are to send me, postage prepaid, one copy of the **OFFICIAL REFRIGERATION SERVICE MANUAL**, as soon as it comes off the press. I understand that the price upon publication will be \$5.00 per copy and this special offer will be void.

Name .....

Address .....

City .....

State .....



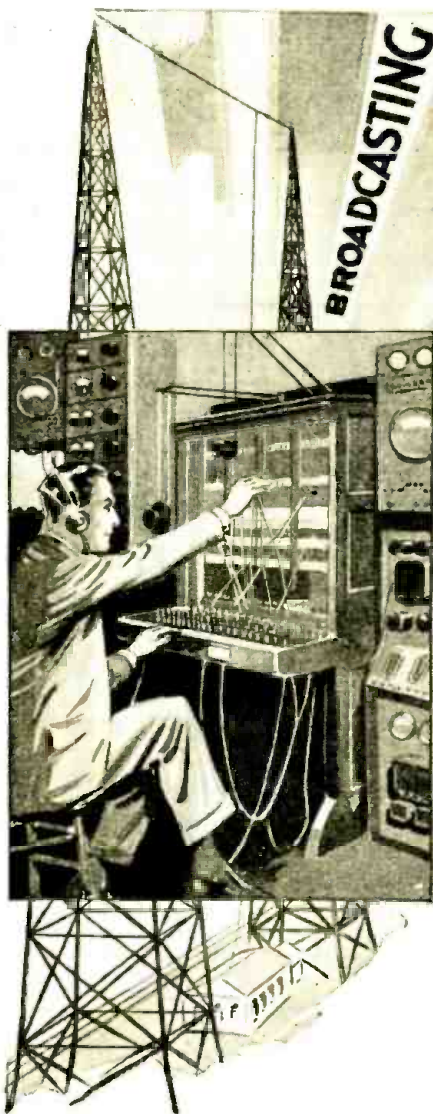

**BROADCASTING  
TELEVISION  
TALKING PICTURES  
WIRELESS OPERATING**

**WIN FAME and FORTUNE  
in RADIO!**

Don't spend your life slaving away in some dull, hopeless job! Don't be satisfied to work for a mere \$20 or \$30 a week. Let me show you how to make real money in Radio—the fastest-growing, biggest money-making game on earth!

**JOBS LEADING TO SALARIES OF \$60, \$70 A WEEK AND UP!**

Jobs as Designer, Inspector and Tester, paying \$3,000 to \$10,000 a year—as Radio Salesman and in Service and Installation Work, at \$45 to \$100 a week—as Operator or Manager of a Broadcasting Station, at \$1,800 to \$5,000 a year—as Wireless Operator on a Ship or Airplane, as a Talking Picture or Sound Expert—HUNDREDS of OPPORTUNITIES for fascinating BIG PAY Jobs!

**Learn Without Lessons in 10 Weeks**

You learn ALL branches of Radio at Coyne—in 10 short, pleasant weeks—NOT BY CORRESPONDENCE, but by actual work on actual Radio, Television and Sound equipment. We don't waste time on useless theory. We give you just the practical training you will need—in 10 weeks' time.

**No Books - No Lessons  
All Practical Work at Coyne**

Coyne is NOT a Correspondence School. We don't teach you from books or lessons. We train you on the greatest outlay of Radio, Television and Sound equipment in any school—on scores of modern Radio Receivers, huge Broadcasting equip-

ment, the very latest Television apparatus, Talking Picture and Sound Reproduction equipment, Code Practice equipment, etc. You don't need advanced education or previous experience. We give you—right here in the Coyne Shops—all the actual practice and experience you'll need.

**TELEVISION  
Is Now Here!**

And TELEVISION is already here! Soon there'll be a demand for THOUSANDS of TELEVISION EXPERTS! The man who learns Television NOW can make a FORTUNE in this great new field. Get in on the ground-floor of this amazing new Radio development! Learn Television at COYNE on the very latest, newest Television equipment.

**Talking Pictures  
A Great Field**

Talking Pictures and Public Address Systems offer thousands of golden

opportunities to the Trained Radio man. Here is a great new field of Radio that has just started to grow! Prepare NOW for these marvelous opportunities! Learn Radio Sound Work at Coyne, on actual Talking Picture and Sound Reproduction equipment.

**Coyne is 32 Years Old**

You get Free Employment Help as long as you live. And if you need part-time work while at school to help pay expenses we'll gladly help you get it. Coyne is 32 years old! Coyne training is tested—proven beyond all doubt. You can find out everything ABSOLUTELY FREE. JUST MAIL COUPON FOR MY BIG FREE BOOK, telling all about jobs—salaries—opportunities. Mail the coupon—NOW!

H. C. Lewis, Pres. **Radio Division** Founded 1899  
**Coyne Electrical School**  
500 S. Paulina Street Dept. C1-8H Chicago, Illinois

H. C. LEWIS; President  
Radio Division, Coyne Electrical School  
500 S. Paulina St., Dept. C1-8H, Chicago, Ill.

Send me your Big Free Radio Book and all details of your Special Introductory Offer. This does not obligate me in any way.

Name .....

Address .....

City ..... State.....

# The Third Supplement to the

## OFFICIAL RADIO SERVICE MANUAL

# Is READY for Distribution

# NOW!

*SUPPLEMENTS Nos. 1, 2 and 3 to the  
OFFICIAL RADIO SERVICE MANUAL  
are obtainable —*

ONE of the most important achievements in recent radio book publishing comes with the completion of the first three Supplements to the OFFICIAL RADIO SERVICE MANUAL. These Supplements, now ready for distribution, are the beginning of a series which will be published every sixty days during the year. The pages of the Supplements are printed exactly like those in the OFFICIAL RADIO SERVICE MANUAL, and as each Supplement is added periodically it will be kept uniform with the original book in paper stock, (loose-leaf form) and in make-up.

The third Supplement to the Manual brings that useful book right up-to-the-minute with the diagrams and schematic circuits of the latest radio models which have been placed on the market during the past few months, as well as with new information of sets for 1930 and 1931.

With each set of Supplements a new index is supplied. The pages are numbered to enable one to include the new additions in their logical places in the original OFFICIAL RADIO SERVICE MANUAL.

Every owner of the OFFICIAL RADIO SERVICE MANUAL will be sure to be up-to-date in radio if he becomes a subscriber to the Supplements. The cost—only \$3.50 a year—is trifling, when it is considered that it is our intention to publish enough Supplements during 1931 to make the present SERVICE MANUAL more than twice the size it is now!

### Some of the features in the third Supplement

Completely revised index for the entire OFFICIAL RADIO SERVICE MANUAL.

Radio—Phonograph installation,  
Wattage of Radio Receivers,  
R.M.A. Color Code,  
Fada Resistor and Condenser Values,  
Canadian Circuits.

### LIST OF CIRCUITS PUBLISHED IN SUPPLEMENT No. 3

Sentinel	Audiola	Electrad
Erla	Philco	Loftin-White
Stewart Warner	Canadian-	Kellogg
Story & Clark	Westinghouse	Bosch
Brunswick	DeForest Crosley	Silvertone
Radiola	Ambassador	New Midget
Victor		Circuits

SUBSCRIPTION PRICE FOR SUPPLEMENT SERVICE

# \$3.50 A Year

EACH SUBSCRIPTION STARTS WITH SUPPLEMENT No. 1.

This is a very small cost when you consider that for the whole year a Supplement will be mailed to you every other month. Those who already own the OFFICIAL RADIO SERVICE MANUAL have concrete evidence of what can be expected from a \$3.50 investment in the Supplements to the original book.

If you are one who has not yet recognized the importance of owning a copy of the OFFICIAL RADIO SERVICE MANUAL, turn to page 56 in this issue and learn more about this valuable book.

Future issues of the Supplements will be ready at the following dates:

July 1st      September 1st      November 1st

MAIL  
COUPON  
TODAY!

GERNSBACK PUBLICATIONS, Inc.      RC-8  
96-98 Park Place, New York, N. Y.

I enclose \$3.50 for which you are to enter my subscription for the Supplements of the OFFICIAL RADIO SERVICE MANUAL. It is understood that the Supplements will be mailed to me at least six times during the year. No Supplement will be sold singly.

Name .....

Address .....

City..... State.....



# HERE'S YOUR CHANCE for ROMANCE and BIG PAY!



J. E. SMITH, President, National Radio Institute, the man who has directed the Home-Study Training of more men for the Radio Industry than any other man in America.

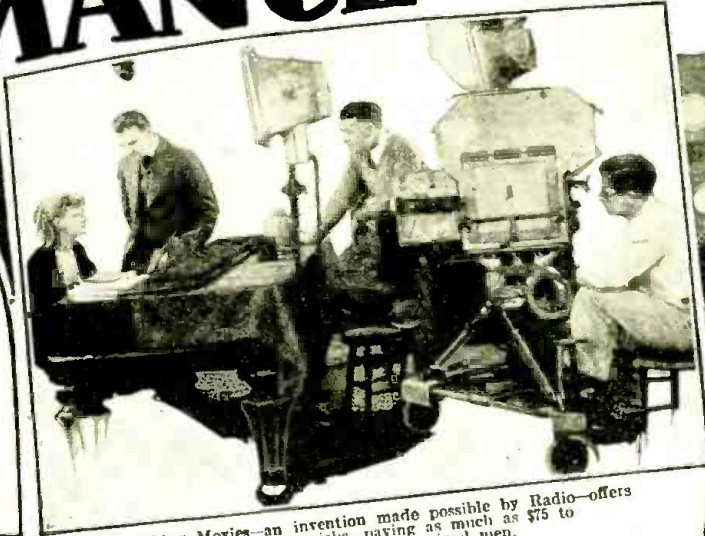

Talking Movies—an invention made possible by Radio—offers many thrilling jobs, paying as much as \$75 to \$200 a week to well-trained men.



Radio operators on ships enjoy life, see the world and get good pay plus expenses.



Broadcasting stations employ hundreds of trained men for jobs paying \$1200 to \$5000 a year.



Aviation is employing more and more trained Radio Men for good jobs on the ground and in the air.



The basic principles of Television—the coming field of many great opportunities—are included in my training.

Get Into These Fast Growing Fields With a Future; I'll Train You at Home in Your Spare Time for RADIO—TELEVISION—TALKING MOVIES. Send Today for My FREE Book of Facts

MAIL the coupon below for my free, 64-page book, "Rich Rewards in Radio." Find out about the thrilling opportunities my home training prepares you for. Get the facts on the big money many N. R. I. men earn—\$50 to \$100 a week. Learn how quickly you, too, should be able to begin earning good pay in Radio. You'll be amazed! There is no other training like mine. It's the only course that enables you to become a RADIO-TRICIAN. Yet it is so simple and practical that no previous Radio experience or even high school education is required to understand it.

### Thrilling Jobs That Pay \$50 to \$100 a Week

Why go along at \$25, \$30 or \$35 a week in dull, no-future work, when the good jobs in Radio pay \$50, \$75 and up to \$100 a week? For instance, my training opens the way to see the world in grand style as a Radio operator on shipboard. There are many splendid openings every year with good pay plus your expenses. You'll also find thrills and real pay in Aviation Radio work. Broadcasting is another field that offers big pay and fascinating opportunities to men who know Radio. And think of the great, thrilling future for men with training in Television and Talking Movies. My free book tells all about these and many other branches of Radio that bring you in contact with interesting people, pay big money and make life pleasant for

you. Moreover, if you want a Radio sales and service business of your own, I'll train you for this field, too. Many new developments, such as Auto Radios, low-priced Midget Sets, etc., are opening new opportunities continually.

### Many Earn \$200 to \$1000 in Spare Time While Learning

Stay at home. Hold your job. Learn in your spare time. I teach you to begin earning almost at once. The day you enroll I'll show you 28 ways to make money on the side, repairing, installing, selling Radio sets in your neighborhood. My new practical method makes this possible. I send you eight big experimental outfits that make clear the basic principles of whatever branch of Radio you choose—and show you how to service practically every type of receiving set made. Many of my students earn \$15, \$20, \$30 weekly on the side while learning. G. W. Page, 2210 Eighth Ave., S., Nashville, Tenn., writes: "I picked up \$936 in my spare time while studying."

### You Don't Risk a Penny

My free book tells all about the big opportunities in Radio, how little it costs to prepare for them and what my Employment Department does to help you get in Radio after you graduate. I back up my training with a signed agreement to refund every penny of your money if, after completion, you are not satisfied with the Lesson and Instruction Service I give you. Mail the coupon for my FREE book NOW. J. E. SMITH, President, National Radio Institute, Dept. 1HX Washington, D. C.

**\$100 a Week**  
"My earnings in Radio seldom fall under \$100 a week. If your course cost four or five times more I would still consider it a good investment." E. E. WINBORNE, 1287 W. 48th St., Norfolk, Va.

**\$300 a Month**  
"I occupy a responsible position as a control operator with the Onondago Radio Broadcasting Corp. I average approximately \$300 a month, including spare time work." Harold WFBL, Radio Station, WFBL, Syracuse, N. Y.

## Get this FREE BOOK



### Mail Coupon Today

J. E. SMITH, President  
National Radio Institute, Dept. 1HX  
Washington, D. C.

Dear Mr. Smith: Send me your free book, "Rich Rewards in Radio," giving information on the opportunities in Radio and your famous 50-50 method of home-study training. I understand this places me under no obligation and that no salesman will call.

Name.....

Address.....

City..... State.....

## Employment Service to all Graduates



**A Better TUBE<sup>®</sup>  
KEEPS  
A Customer  
LONGER  
Satisfied**



WHEN you speak about the replacement —you should talk PERRYMAN.\* You as counsel to your customers must be backed by a tube of outstanding quality. PERRYMAN tubes meet the most exacting requirements and will build permanent good will and an ever increasing volume of sales for you.



Your stock should include a varied supply of PERRYMAN Tubes. Write Dept. RC for the name of nearest wholesale distributor; also our special proposition for service men.

PERRYMAN Tube production has increased steadily during the past few months to keep pace with the demand for new tubes. The new low list prices have been carefully adjusted to enable dealers and servicemen to make a fair profit—PERRYMAN Replacement Policy assures recommendation by others for new tubes.

**PERRYMAN ELECTRIC CO.**  
INCORPORATED

NORTH BERGEN :: :: NEW JERSEY

**PERRYMAN**



**RADIO TUBES**





“Takes the Resistance Out of Radio”

Editorial Offices, 96-98 Park Place, New York, N. Y.

# Radio and Prosperity

By HUGO GERNSBACK

**I**T IS a curious fact that, ever since radio became a recognized industry, there has always been dissension in its ranks, instead of the industry's working for its common good. This condition developed immediately after the height of the 1922 boom; and there has been dissension ever since.

Whatever one group of radio people do, another group will promptly denounce and decry. Whenever a pioneer brings out something new, he is promptly set upon and denounced by the industry. Of course, these outcries are usually traceable to selfish reasons; because every manufacturer does not like to direct his efforts continually into new fields.

When the loud speaker first made its appearance the head-phone manufacturers were, naturally enough, loud in denouncing the “rattletraps” which (so the 'phone manufacturers claimed) were ruining the industry by driving people away from radio instead of into its folds. Of course, the inevitable happened; the loud speaker triumphed, and the 'phone manufacturers went out of business, except for those who saw the handwriting on the wall and made loud speakers themselves.

It was thus less than two years ago; when the Pentode was announced in America for the first time, and RADIO-CRAFT ran the first article on it. The Pentode was pooh-poohed and made sport of by the radio industry. Today, all those radio manufacturers and others, who cried loudest, are featuring the Pentode in all receivers.

A year or more ago, when the midget set arrived, nine out of ten of the radio industry were in violent opposition; and they denounced the midget set in no uncertain terms. As usual, we find that, today, those who were the most vociferous and apoplectic in their denunciations are themselves making midget sets.

It is a fact that, from 1919 until 1922, when radio was booming, there was no dissension; and, as Dr. Julius Klein, Assistant Secretary of Commerce, said in a recent address at the Radio Show: “Radio in 1921-22 helped to bring the country out of the depression that prevailed at that time.” As Dr. Klein put it: “Radio has played an important and helpful rôle in the depression. It has helped psychology outside of the lower end of Manhattan Island, where the psychology is unique. One of the invaluable elements of these reconstructions is the vigorous participa-

tion of new industries. In that respect radio was an invaluable contribution in accelerating our recovery after the slump in 1921-22.”

“The radio industry rendered invaluable assistance in the great task of lifting American business out of the post-war collapse,” continued Dr. Klein. “It can again render an equal service by conserving fully the assets of vigor and resourcefulness which are so conspicuous in this young giant in the business world.”

All these preliminary remarks are leading up to the point which I wish to make today, and that is—Television. Nine out of ten radio manufacturers, whether they make parts or sets, are today pooh-poohing television just as loud as the 'phone manufacturers were pooh-poohing loud speakers some years past. The radio manufacturers, who should today shout “Television!” most boldly from the roof-tops, are croaking dismally and are running around aimlessly because they apparently do not know what to do next. They seem not to have awakened as yet to the fact that there is today an actual, healthy demand for television material.

It is perfectly true that television today is crude; for that matter, as crude as radio was in the crystal-detector stage. Yet, if all the croakers would jump on the television bandwagon, and if they had as much courage as they had in 1920, they would soon forget their lamentations. They would find that television is again repeating radio history, as radio broadcasting did in 1920.

By next year, the present crepe hangers will be a sorry lot; because they will have found either that someone has beaten them to it, or that they are lagging behind in an industry that should be rightfully theirs.

There was a time when the radio industry believed in the future of radio, and had the courage of its convictions. In many of our so-called radio leaders, this quality seems to have vanished; but, as usual, newcomers who have more courage will take their places, unless the old-timers wake up speedily

and do something for themselves before it is too late.

And, make no mistake about it, television is here this time to stay. During the next three years it will rival the present radio industry, and reach heights that no one today believes possible.

**N**INE out of ten radio manufacturers, whether they make parts or sets, are today pooh-poohing television just as loud as the 'phone manufacturers were pooh-poohing loud speakers some years past. The radio manufacturers, who should today shout “Television!” most boldly from the roof-tops, are croaking dismally and are running around aimlessly because they apparently do not know what to do next. They seem not to have awakened as yet to the fact that there is today an actual, healthy demand for television material. . . .



# The Radio Typewriter

*Details of a new invention which promises rapid and secret transmission of written messages.*

**M**ANY years ago, when the first telegraph lines were being pushed into the Great American Desert (which then occupied most of the map of the United States west of the Missouri River), a group of wondering redskins gathered around the linesmen, and asked for an explanation of the white man's "medicine." The technicalities were difficult to translate into any terms mutually intelligible; but the final result was very instructive.

"We have a dog," said the resourceful operator, "so long that his head is in Omaha, and his tail is here. Now, when I pinch his tail—" and he pressed the key—"his head in Omaha will bark." Which satisfied the curiosity of Poor Lo.

Now we have something a little more mechanical; when we press the keys of a typewriter in Chicago, the typed sheet will roll off the carriage in New York. The automatic receiving machines used in telegraph offices, in newspaper service, etc., are today quite familiar; they have land-line connections. Now we have a radio-operated typewriter, which presents very interesting possibilities in the line of communication; it requires only a channel of operation of very narrow width.

The apparatus illustrated on this page is the invention of Glenn W. Watson of Detroit, who was led to its conception during researches on the problem of synchronization between pictures and voice broadcasts.

In previous type-printing devices operated at a distance, a system of relays is used. For instance in ordinary radio code, the letter "Q" is represented by two dashes, one dot, one dash (— . —). We may receive this signal by ear alone; we may construct a visual recorder which will show the dots and dashes as such, or a wavy line,



Fig. A

Mr. Watson at his transmitter-typewriter, the circuit of which is Fig. 1. The commutator is at the upper left of the machine.

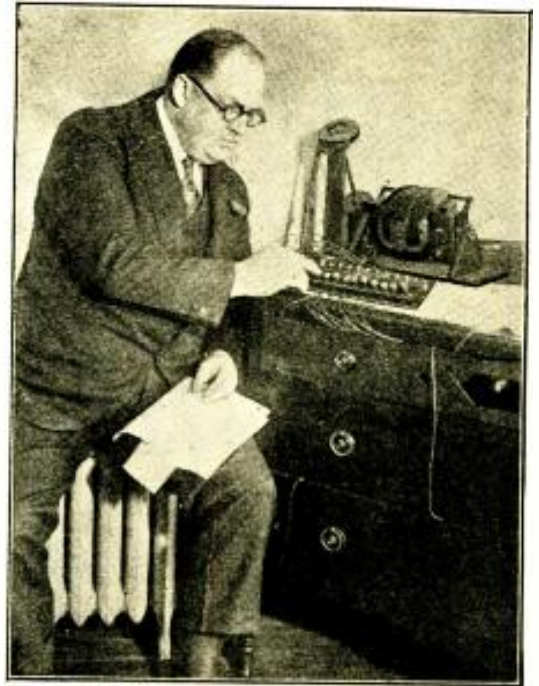

on a piece of paper; or we may make a mechanical device which will print the letter "Q" as soon as the dots and dashes have been received—after the proper delay, to make sure that there are no more signals to come for that one letter. It is true that, for a mechanical-relay system, some other combination may be preferable to indicate "Q;" but the principle is not altered.

Mr. Watson, on the contrary, has devised

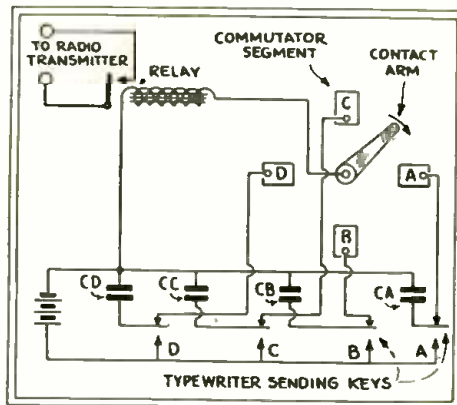

Fig. 1

Simplified circuit of the transmitting typewriter; the condensers are 2-mf. capacities.

his machine to send out just one impulse or dot for each letter.

That is to say, for instance, when the

sending-key for the letter "D" is depressed, the battery A is closed across the condenser CD (Fig. 1) for an instant; and the condenser is charged. At the instant that the contact arm touches the "D" segment on the commutator, the condenser will be discharged through the relay, which effects the keying of the radio transmitter. There is an impulse impressed at once on the outgoing carrier wave.

At the receiver, this carrier wave is picked up in the usual manner, amplified at radio frequency, and detected; the "dot" corresponding to the letter "D" is passed through an audio-frequency amplifier, and sent to the thyratron tubes.

In the printing apparatus, there is another contact arm, and a commutator revolving in isochronism (and practical synchronism, allowing for the electrical delay) with that of the transmitter. The dot "D" comes on the grids of the thyratrons, just as the contact arm closes the plate circuit of one of them through the "D" commutator segment; the impulse causes plate current to be released from the thyratron.\* The flow of this current through a solenoid jerks down the armature of the latter, to which is attached a printing key bearing the letter "D"; this character is thereby impressed on the paper in the receiving typewriter's carriage.

The contact arm, however, is still sweep-  
(Continued on page 113)

Fig. B (left)

The receiving typewriter at the left, with its short-wave receiver at the right. The latter is standard. The machine has a commutator rotating in exact synchronism with that of the transmitter.

Fig. 2 (right)

The fundamental circuit of the receiving typewriter; the solenoids are relays which operate the type bars of the machine. Its rapidity is limited only by mechanical considerations.

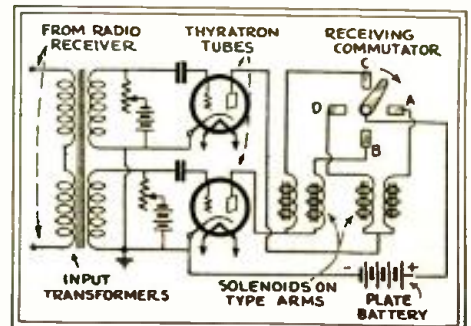

\* See "The Thyratron," on page 150, of the September, 1930, issue of RADIO-CRAFT; also page 659 of the May, 1931, issue.

# The Latest Radio Appliances

*New Commercial Products of interest to the radio trade, Service Men, and radio constructors.*

## DISTRIBUTION-CONTROL PANEL

**O**PERATION of any number of speakers from a single audio amplifier, whether for demonstration and comparison, or for a public-address system, is obtained by the use of the control panel illustrated in Fig. A; the simplicity of the connections may



Fig. A

*This panel controls sixteen speakers.*

be seen from Fig. 1, which gives the schematic circuit of the equipment. It will control distribution to and volume of, any number of reproducers from one up to sixteen; jacks are provided for the use of a monitor at the panel. Public halls, schools, hotels, hospitals, restaurants, multiple and large dwellings, etc., as well as show rooms and laboratories, may utilize apparatus of the kind in a sound equipment installation.

(Manufacturer, Bud Radio, Inc.)

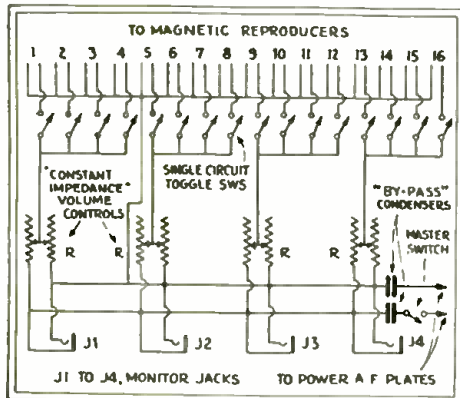

Fig. 1

*Complete diagram of the control panel.*

## SMALL INTERMEDIATE CONDENSERS

**S**UPERHETERODYNE practice, with its insistence on compactness, has resulted in the appearance of a new intermediate-frequency tuning condenser of particularly small dimensions; it measures only 1 15/16 in. in diameter. The available capacity ranges are from 10 to 79 mmf.; 70 to 140 mmf., and 140 to 220 mmf. The unit is designed for high efficiency.

(Manufacturer, Hammarlund Mfg. Co.)

## PERMANENT-MAGNET DYNAMIC

**I**N Fig. B is illustrated a permanent-magnet dynamic reproducer, the first of a series just designed. Although this type of reproducer has been available in Europe for some time, no American manufacturer has hitherto put on the market a "moving-coil" loud speaker deriving its high-density magnetic flux from a permanent-magnet system, instead of the standard electromagnet or "field-coil" unit.

Although this reproducer is of midget proportions and, in consequence, adaptable to mantel-type receivers, its magnet system weighs eight pounds; and it cannot, therefore, be recommended as a portable unit.

The one-piece molded cone developed for it bears the trade name "Tym-Flex." The manufacturer recommends this particular model for use in conjunction with battery-operated radio sets. In timbre it is said

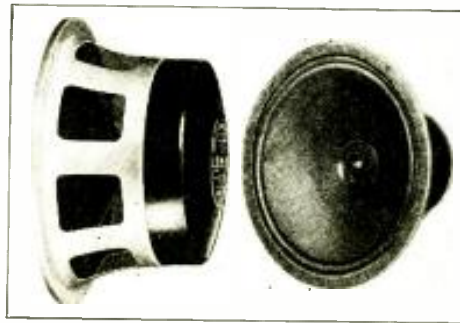

Fig. B

*The permanent magnet needs no field current.*

to be similar to the standard, higher-power electrodynamic type.

(Manufacturer, Jensen Radio Mfg. Co.)

## PENTODE ADAPTER

**A**NEW adapter has been added to the many previously available. Its design is based on the discovery that the suppresser-grid of a pentode tube (which operates at

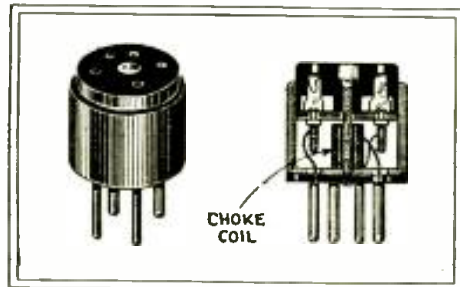

Fig. D

*This adapter fits a pentode into any set.*

approximately the same potential as the plate) may be powered from the plate terminal of the pentode tube if an A.P. choke coil is introduced into the lead; so that only the D.C. potential is applied to the suppresser grid. The completed adapter is shown in Fig. D.

The adapter is provided with a 5-prong UY receptacle and a 4-prong UX base; it will take a type-47 (2.5-volt) pentode and

fit it to the output audio socket in place of a type-45 power tube; no other change in the set is required. Similarly, a 33 may be substituted for a 31. Two adapters are required for push-pull circuits.

It may be found, in some instances, that the power output of the existing pack is insufficient to take care of the pentode. However, where this adapter has been used hitherto, the audio output volume has been considerably increased; the voltages automatically adjusting themselves within the circuit.

(Manufacturer, Blum the Radio Man, Inc.)

## ALL-AROUND POWER PACK

**T**HE unit pictured in Fig. C is a new "A, B, C" supply unit for complete operation of an A.C. receiver. In addition to furnishing current at all appropriate voltages, for the operation of the standard receiver with push-pull 45 output, it may be adapted to many other needs of the constructor, or modernizer of older sets; the filament windings provide a wide option.

The primary may be compensated for 110- or 120-volt supply, by means of a clip fuse. Four filament secondaries supply 12 amps. at 2 1/2 volts; 3 1/2 amps. at 2 1/2 volts; 1 amp. at 5 volts; and 6 amps. at 4 volts. (The last-mentioned winding, though designed with a view to export requirements, may serve the purposes of the experimenter;

(Continued on page 110)

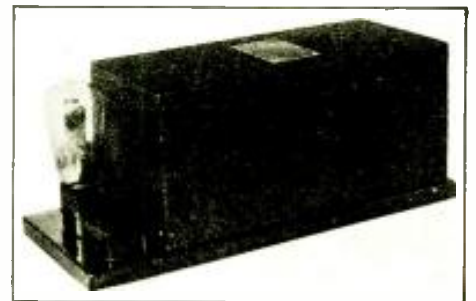

Fig. C

*A versatile heavy-duty power pack.*

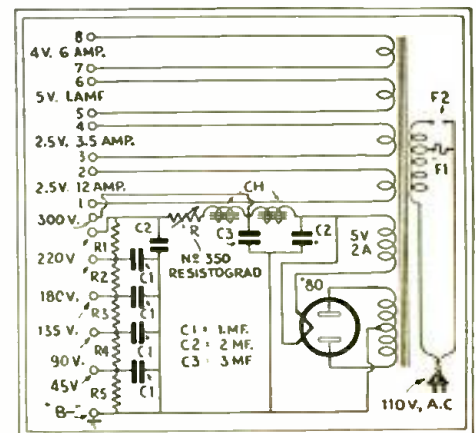

Fig. 2

*Circuit of the power unit pictured above.*



# Fitting One Chassis to Three Cabinets

*How a modern design makes it possible to adapt a single receiver design to widely varying decoration schemes.*

**D**ETAILED descriptions of the interesting developments in receiver design, during the past few months, have included a group of the latest Crosley models; each of which has presented several new and ingenious features for examination.

A new mark in successful reduction of chassis and cabinet size was given in the lilliputian "Wigit"; the superheterodynes, after a considerable period of research, appeared in this manufacturer's line with the "Model 120" ("Sondo," "Rondeau" and "Administrator"); and, after a brief period of incubation, the dynatron oscillator, together with the newest tubes—the

The first of these is a stately model, accentuating the vertical lines, and taking little floor space; above it houses an electric clock; in the center, the chassis; and, beneath, a dynamic reproducer. This is the "Oracle"; it stands 61½ inches high, is 14 wide, and 9¾ deep.

The mantel-type set, shown reposing on a table top in the photograph, is 14 9/16 inches high, 11 11/16 wide, and 9 5/8 deep; it is known as the "Show Boy."

The larger cabinet is 35 1/8 inches high, 23 3/4 wide, and 12 1/4 deep; its poetical title is "Sonneteer."

The chassis itself is illustrated in Fig. D; and its position in the "Oracle" case is

Fig. A

The Crosley "Oracle" is largely cabinet; yet it contains an electric clock, as well as a standard reproducer.



shown in the rear view of the latter—Fig. E. It incorporates four receiving tubes—two '35 variable-mu; one screen-grid '24 detector; and a pentode power output tube,

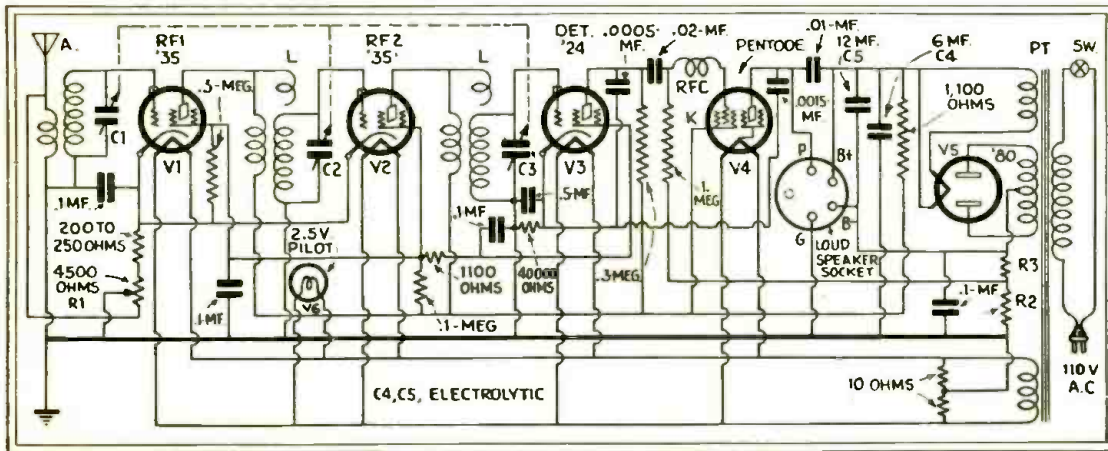

Fig. I (left)

Schematic circuit of the Crosley "Model 59." The field coil is between "G" and "B-"; the pentode's biasing resistor R2 is 300,000 ohms, R3 one megohm.

variable mu and the pentode—were presented, together, in the miniature "Super Buddy Boy"\*\*\* a mantel-type superheterodyne whose voice is as strong as its dimensions are small.

The latest Crosley product is distinguished by its versatility: that the three receivers illustrated here house the same ("Model 59") chassis may be surprising. This one compact unit serves for the tall, thin "pier-clock" cabinet of Fig. A, the midget of Fig. B, and the low-boy console of Fig. C.

\*April, 1931, issue of RADIO-CRAFT, page 603.  
 \*\*Data Sheet No. 43, page 720, June, 1931.  
 \*\*\*July, 1931, issue, page 20.

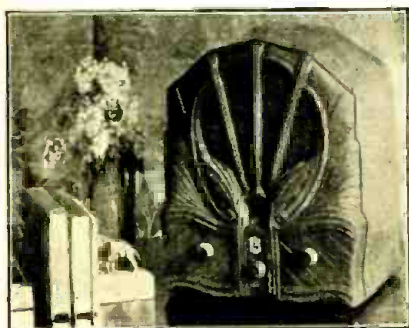

Fig. B  
The Crosley "Show Boy."

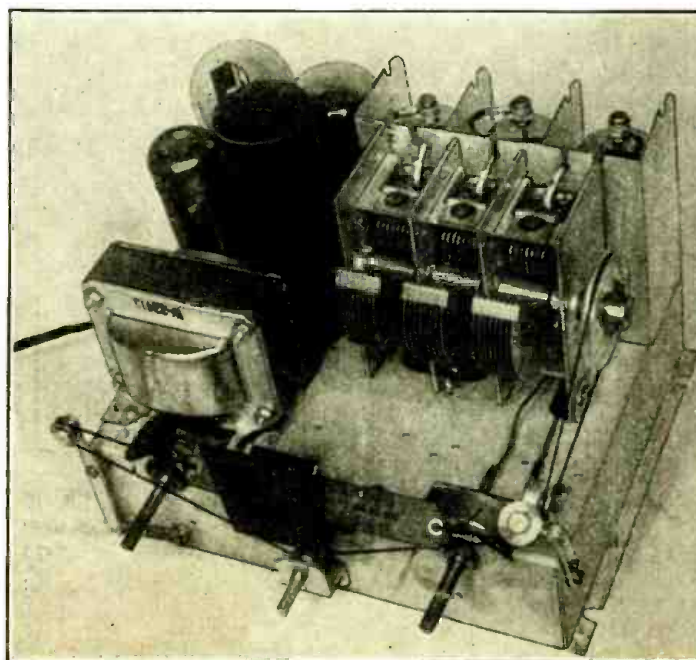

Fig. D

Left, the "Model 59" chassis, used in the three very different cabinets shown. Right, a rear view of the "Oracle": A, electric clock; B, removable tube shield; C, speaker plug; D, "Tennaboard" built-in aerial; E, dynamic reproducer.

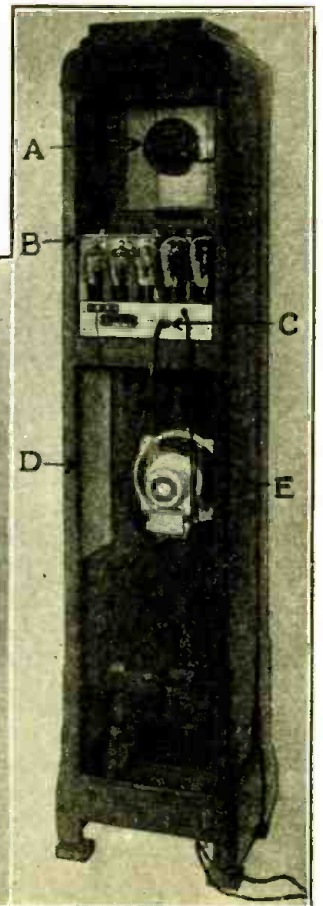

Fig. E



# The Radio Robot

*How the "Iron Man" is caused to go through his routine under phonograph control; or by light signals.*

By H. G. CISIN, M.E.

the new '47—the rectifier is the standard '80. The front view of the chassis shows prominently the "angular-vision" ribbon scale described in the previous issue of this magazine; and which, with its vernier driving knob, makes tuning equally convenient from a seated or a standing position.

Noticeable in the construction of this chassis is the attention which has been paid to increasing its accessibility for the Service Man. The three knobs may be pulled off in an instant, as they are held in place only by spring pressure; two holding screws are removed, and the "antenna" and "ground" leads are disconnected from the push-type binding posts. The assembly may then be pulled from its cabinet.

To replace tubes, the one-piece aluminum shield which fits over the top of the three screen-grid types ('35s and '24) may be taken off easily; it is held, under spring tension, only by two thumbscrews.

Volume control is obtained (see the



Fig. C

The "Sonneteer" also uses the "59" chassis!

schematic diagram, Fig. 1) with the potentiometer R1 which, by its position in two circuits, serves the double function of varying the cathode bias on both variable-mu tubes, and reducing the antenna's signal input to the first of them (V1).

The field coil of the dynamic reproducer, in the "B—" lead of the filter unit, in conjunction with the two high-capacity electrolytic condensers C4 and C5, serves to smooth the plate current adequately; the necessarily low control-grid bias for the output pentode V4 is obtained by tapping the voltage divider R2-R3 which shunts the field coil.

The R. F. transformers employ a late design, developed by the Hazeltine Laboratories, to equalize sensitivity throughout the tuning range; correct tone is maintained in the audio amplifier with resistance-capacity coupling between the screen-grid detector V3 and the output '47 tube V4, by using correct bypass capacities. The plate of V4 is bypassed to the cathode of V3 by an .0015-mf. condenser; and the primary of the output transformer is shunted by .01-mf. Other constants may be determined from Fig. 1.

**O**PERATION of the radio robot, described in the preceding issue of RADIO-CRAFT, may also be directed by the use of a phonograph; which converts the figure into an automaton, going through a previously-rehearsed act, and relieves the operator from the task of giving each signal.

Fig. 8 shows the arrangement which enables the robot to deliver a speech, originating either from a phonograph record or from the operator, via the microphone. When using an electric phonograph, this is attached to the input of a good audio amplifier (such as the Electrad Type C-250 direct-coupled unit.) Where the microphone is used, a microphone amplifier MA, also is necessary, as indicated. The output of the direct-coupled amplifier is connected to the loud speaker, located in the chest of the robot. The neon lamp N, for lighting up the teeth and eyes, is also connected to the output of the amplifier.

The method used, to cause "Mr. Radio Robot" to go through an entire series of pre-determined acts, is illustrated in Fig. 9. For example, suppose it is desired to have him stand up, make a speech, lift his right arm at a certain point in the speech, fire a gun at another point, and then sit down when the speech has been completed.

This calls for five selective tuning cir-

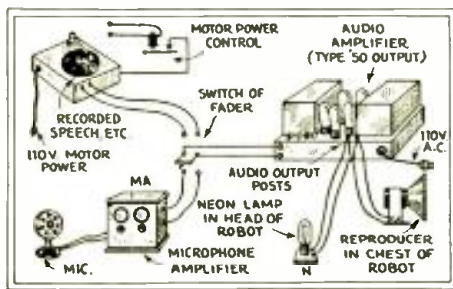

Fig. 8 (above)

Either a microphone message from the mouth of the operator, as explained in Part 1, or a record picked up from a phonograph disc may be used to control Mr. Radio Robot. The record enables a long act to be gone through, as rehearsed; while it may be cut into at any moment.

Fig. B (right)

The Electrad portable amplifier, which may be used with either microphone or record, lends itself well to the operation of a robot. Observe the plug used to cover the reproducer when the unit is packed.

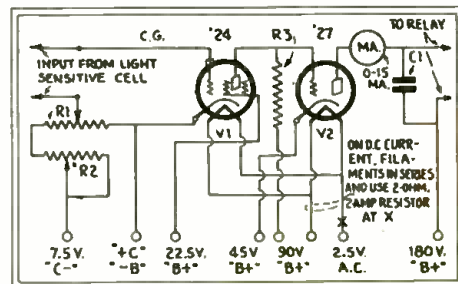
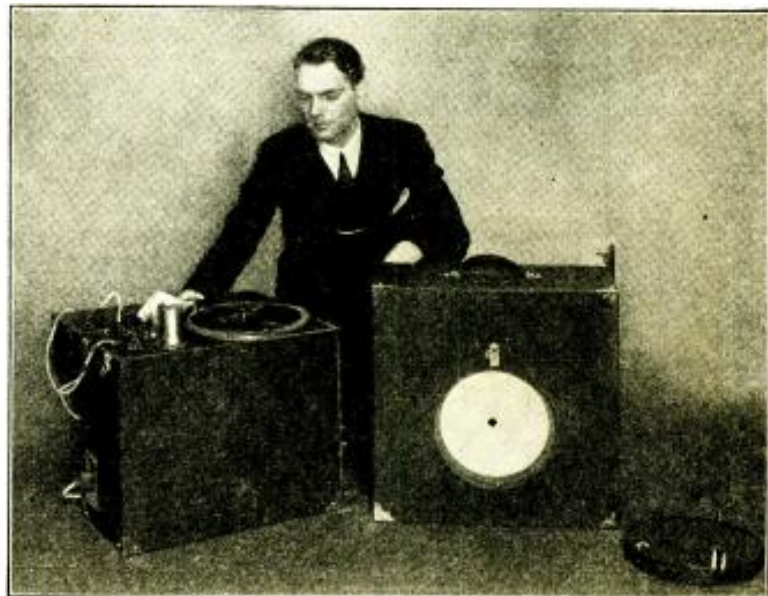

Fig. 10

To convey a signal to the robot by light (or darkness) this amplifier is used.

cuits, actuated by five tuned vibrator reeds. The actuating tones are received from a phonograph record. Discs are available (used for testing frequency-response of loud speakers) which contain "pure" notes of many different frequencies.

The electromagnetic pick-up is connected to the input of an Electrad Type A-245, or equivalent amplifier, and the output to a small dynamic speaker within a wooden box containing the selective tuning circuits. The details of these circuits are similar to those shown in Fig. 3, except that only one tuned vibrator reed is used for each circuit. The reeds are arranged to respond to the notes on the phonograph record, in the desired sequence. Thus the reed controlling circuit No. 1 is actuated by the first note. The weak signal generated is amplified by amplifier No. 1; passing to rectifier No. 1, thence to the time-delay relay (used as explained above to prevent chattering of the reed), which in turn actuates the No. 1 power relay. This is connected to the STAND terminals shown at the left of Fig. 7.

In like manner, the record note operates after a desired interval of time, to actuate

(Continued on page 105)



# Remote Control of Radio Reception

*The third article of a series describing the elaborate modern installation of a large hotel*

By ELI M. LURIE, B.E.E.\*

**I**N the two previous issues of RADIO-CRAFT Magazine, the guest room radio service in the Hotel New Yorker has been described, with possible methods of designing similar equipment. The remote-controlled public-address apparatus will be described in the same manner. Its control panel, located on the fourth floor, is shown in Fig. E.

A practical remote-control system, in every sense of the words "Remote Control," necessarily consists of apparatus with which the reception of broadcast stations does not depend on a series of buttons which tune the associated receiver to a specified group of stations. Rather, it should be actually possible to "sweep the dial" from 200 meters to 600 meters, not with buttons, but with a calibrated dial located on the remote-control box; which should be light weight, and small enough to be carried around without being cumbersome. Also, to operate the remote-control system, it should be necessary only to plug the box into a wall outlet; operation should then be as complete as though one were tuning the radio manually.

Continuing these premises, the installing engineers considered that complete control should be obtainable whether operation is desired from beside the receiver, or from any location in the hotel—whether in the radio room on the 41st floor or forty stories below in the auditorium or ballrooms. The

\* Chief Radio Engineer, Hotel New Yorker.

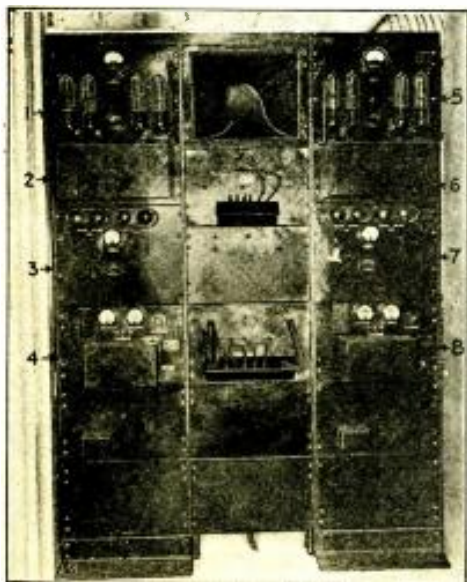

Fig. E

The "New Yorker's" public-address panels: 1, 5, 50-watt ("43.4") amplifiers, fed from "42.4" amplifiers; 3, 7, 4, 8, speech amplifiers; 2, 6, rectifiers. Below reproducer, plug outlets, and inlets from the remote-control lines.

location should require only a remote-control outlet in order to produce perfect control. The volume should be controlled by a motor-driven attenuator, also operated from the remote control box; for it then becomes possible to introduce as many inputs into the system as desired. The attenuator can be made to act as a fader and will fade out the radio system, and fade in the output of a microphone, phonograph, or other device.

At the present time there are several methods of completely tuning a radio receiver by remote control.

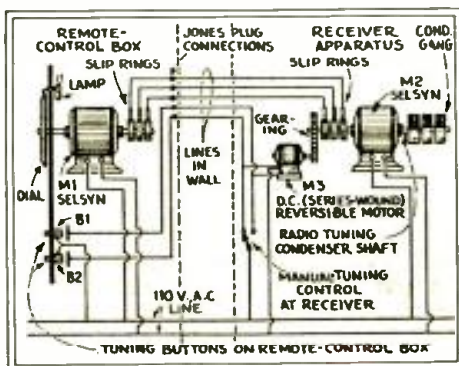

Fig. 7

The "Selsyn" system of remote control, by two interconnected induction motors, is used in many high-grade installations.

One, which uses a "step" motor, or a "six-point" motor (M, Fig. F) is used to tune the radio receiver in the hotel.

### The "Selsyn" System

Another tuning arrangement makes use of two special motors, known as the "Selsyn" type, which are primarily three-phase, wound-rotor induction motors with similar impedance characteristics. One of a set is geared to the tuning control of the radio receiver, and the other is installed in the remote-control box.

The method of operation is to connect the three rings of one to the corresponding three rings of the other. The stators are likewise connected together, and a common and constant source of A. C. is applied to the stators as shown in Fig. 7. Now, if the rotor of one motor is turned (regardless of which machine it may be) the rotor of the other motor will revolve and keep exactly in step with the first.

This arrangement is by no means new; for the principle used for the synchronism of these motors, that of electrical interlocking, was first discovered by Michalke back in 1901.

There will always be between the rotors of the two machines a definite phase angle which varies with the load. The result will

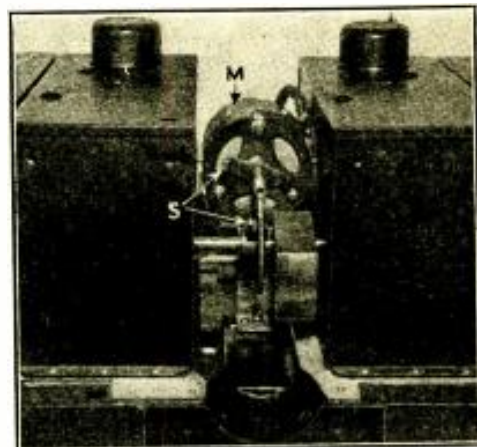

Fig. F

A close-up of the remote-controlled radio receiver; M is the tuning motor, operated from the control box, and S the stops.

be an E. M. F., acting on the circuit of the rotors, which will tend to pull them into synchronism by producing a synchronising torque. The action is similar to that of a synchronous motor and a generator where the motor is operating from the voltage developed by the generator. In such a case, the motor is constantly developing a phase-angle "difference" between itself and the generator; but the synchronising voltage acting on the motor continues to draw it into complete step or synchronism.

In practice, a small reversible third motor M3 is geared to the Selsyn motor at the receiver. The lines for the reversible motor are run to the remote-control box and so arranged that its direction can be reversed by means of two buttons B1, B2. Now, if the Selsyn motor at the receiver is attached directly to the main condenser

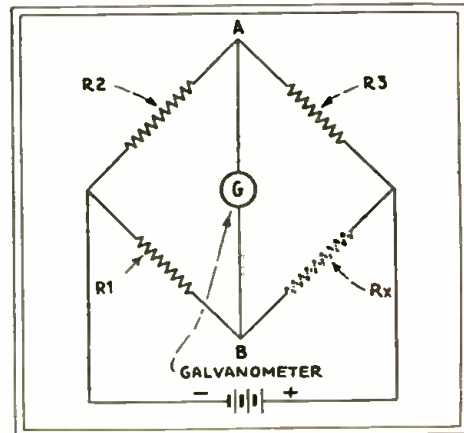

Fig. 8

For any value of R4, a certain amount of current must flow through G.

shaft of the radio, the tuning for any station can be obtained by merely pushing one of the two buttons on the remote-control box. The small additional motor M3 will drive the Selsyn motor at the receiver, and the Selsyn motor M1 in the remote-control box will keep exactly in step with it. A dial on this motor will therefore indicate the position of the tuning condenser shaft in the radio receiver.

### "Bridge" Tuning

There is still another method which, when put on the market, should prove to be the neatest, best, and cheapest yet developed for remote control. Though things are still

in the dark at present, the principle is not by any means new, and should be quite interesting.

Every radio man knows the principle of measuring resistance. In Fig. 8 is shown the circuit of a common resistance-measuring bridge; three of the resistors  $R_1, R_2, R_3$  are known values. To find the value of the assumed  $R_x$  it is necessary to make a "null" adjustment or to vary the value of the other resistors till no current flows.

Now, the principle of this new remote-control system is just the reverse of the

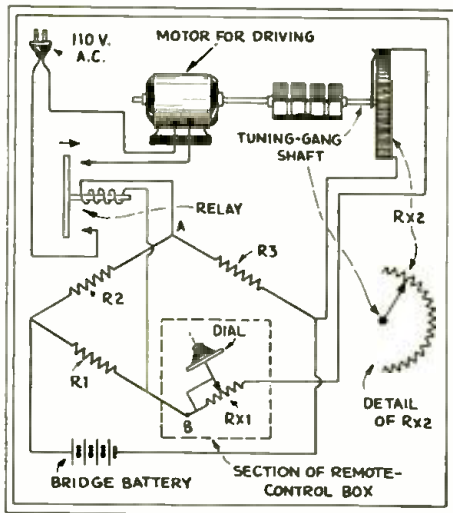

Fig. 9

Application of the Wheatstone bridge principle to remote control is still under development.

above; it is shown quite clearly in Fig. 9, although the diagram does not indicate how the direction of rotation of the motor may be reversed. This is one of the problems now being worked out.

In practice, the operator inserts at  $R_{X1}$  the value of the resistance which corresponds to a definite point on the tuning dial; this results in a difference in potential across  $AB$ , causing the relay to close. The motor then receives energy and, therefore, starts and rotates the dial of the receiver; but, at the same time, it performs a null-adjustment by varying  $R_{X2}$ . The motor continues to rotate only as long as there is

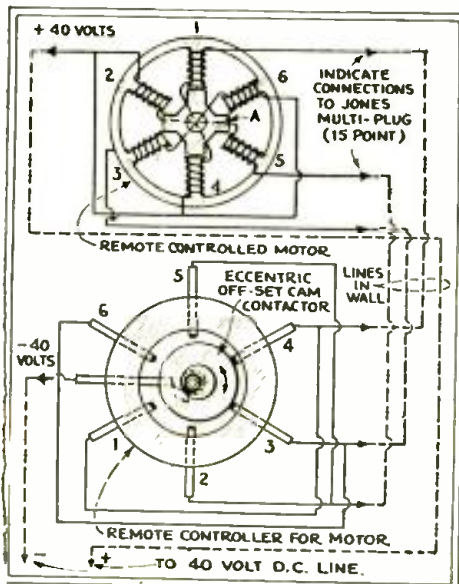

Fig. 10

As the offset cam contact of the control box turns, so does the motor at the receiver.

an unbalanced condition in the bridge and, as soon as a balanced condition is obtained, the motor comes to rest. It is, therefore, necessary only to have a resistance with a sliding contact on it and, by merely pushing the slider one way or the other, complete remote tuning may be obtained.

The "Step" Motor System

As mentioned before, the remote-control system used at the New Yorker makes use of a "six-point" or "step" motor; which might be compared in action to a D. C. shunt-wound motor. The only difference is that commutation is obtained at the remote-control box instead of at the motor; and the field rotates, instead of the armature.

The rotor ( $A$  in Fig. 10) is a solid bar of plain soft iron which, in itself, has no inherent magnetism, but whose magnetic poles are dependent on the flux due to the armature or stator poles. The stator fields are so arranged that the direction of the current in them produces a north-and-south polarity on opposite poles; but at the same time, the adjacent poles are opposite in polarity to the first two. This results in adjacent north and south poles operating together and producing a twisting torque which advances the rotor about  $1/24$ th of a turn, or until the north pole is directly under the south pole. (The general idea is illustrated in Fig. 10A.—*Tech. Ed.*) By gearing the arrangement, it is actually possible to tune sharp enough to cut sidebands!

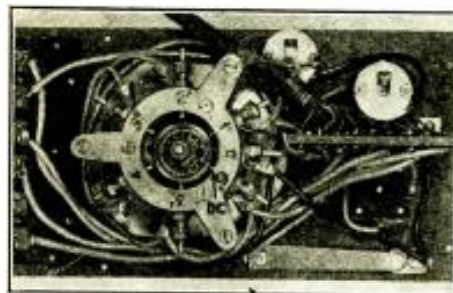

Fig. G

The interior of the remote-control box; the eccentric ball-bearing cam is making contact at DC. (Compare this with Fig. A.)

A motor of this type requires four lines from the remote-control box, as shown in Fig. 10; in operation, as shown in Fig. A (in Part I, in the June issue), a vernier dial on the remote-control box is used for tuning. The dial-operated commutator is shown in Fig. G; the tuning operation produces commutation, and the motor advances or retards smoothly, depending on the direction of tuning. The motor operates on 40 volts D. C., and uses about 17 watts.

The chief disadvantage of the motor is the heating, due to the fact that the rotor is a solid piece of soft iron and, therefore, subject to high eddy-current loss. Also, because the motor always remains in the circuit, even when not tuning, the armature coils which are connected to the line develop a large amount of heat. Position variation is slight, and the motor can always be reset by merely rotating the dial until the motor has traversed both extremities of the tuning spectrum.

As a summation of the three methods discussed, the Selsyn motor offers the best so-

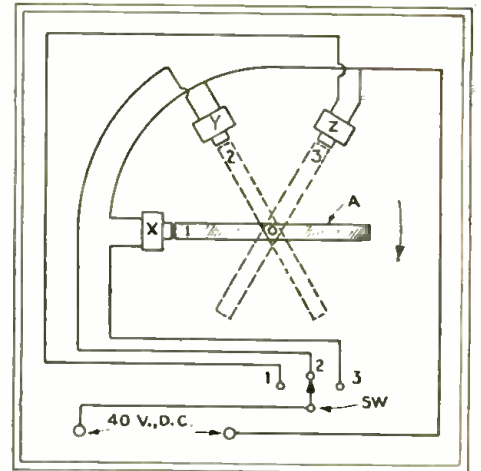

Fig. 10A

Principle of the "step" motor; successive contacts pull the armature completely round. A step-down gear reduces the jerkiness of the action.

lution for the remote-control problem; at least until the bridge method is put on the market. The method used at the New Yorker is applicable only where a D. C. source is available.

Remote Attenuator and Fader

Methods of attenuating and fading from one input to another present another problem that is not easily attacked; one might simplify it, where only one input or output is to be controlled, by merely running three lines to a potentiometer which could be located on the remote-control box, and then using this control for volume attenuation. (The control may be used to vary the screen-grid voltage of the R. F. tubes or may be connected to the receiver in any other way to vary the volume.) But, where there is more than a single input to be remotely connected to the main amplifier system (as for radio, phonograph, microphone, and sound pictures) and the volume at the output must also be controlled, the problem becomes more complex.

The solution rests in the use of a motor-driven attenuator. (See Fig. H.) By using such a device, any number of inputs may be controlled. At the same time, it is possible to use the device not only as a fader, but also as a volume control. To do this, the fader works in conjunction with a potentiometer which varies the plate voltage

(Continued on page 116)

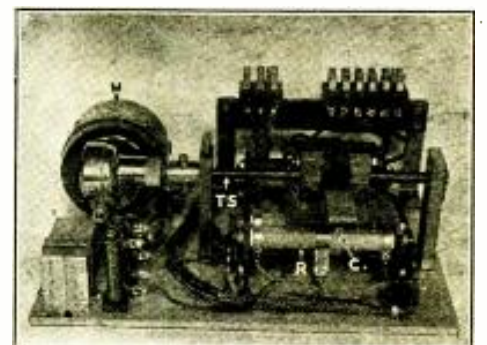

Fig. H

The motor-driven attenuator and fader; the threaded feed-screw  $TS$ , turned by motor  $M$ , pulls three roller contacts over resistance strips (represented respectively by  $C$  and  $R$ ).



# Recording Equipment and Its Operation

*A review of types of commercial apparatus designed for "instantaneous" recording of sound on discs*

By GEORGE J. SALIBA, S.B.

**W**HENEVER a new art, still in its embryonic stage, is introduced to the public, the development and perfection of that art lies with the amateur who is willing to spend without stint both time and money to satisfy his desire to achieve results in a field which is considered very technical. But he is, usually, handicapped at the outset of his quest by inability to find and procure the proper apparatus with which to conduct his experiments.

And home (or, as it is now known in the trade, "instantaneous") recording, a comparatively new development in the associated fields of acoustics and electronics, seems to be passing through just this dark stage; since the writer finds that, judging by the letters elicited by previously published articles\*, enthusiasts of this art are experiencing inability to obtain the necessary materials with which to carry on their work.

Today the handicap is due largely to the fact that manufacturers of home recording equipment are averse to advertise extensively; not yet realizing the magnitude of this relatively new and interesting field or the interest that has been aroused by previously published material, and the repercussion—its application.

Since this equipment is usually a side-line, it is the amateur—the one who should be

\* The author refers to his articles, "Instantaneous Recording of Sound on Discs," in the June, 1931, issue of RADIO-CRAFT, and "How to Improve the Quality of Radio and Personal Recording," in the succeeding July issue. See also the article, "Home Recording of Radio Programs and Speech," in the December, 1930, issue.—Tech. Ed.

given every possible aid—who is made to suffer. To sweep away this curtain of secrecy, it is the purpose of this article to describe in considerable detail, and with an eye to their practicability, some of the equipment now available on the market.

## A Modern Recording Machine

A particularly interesting recording machine (Fig. A) is manufactured by G. J. Badgley & Co. While intended for use with blank ungrooved records, such as aluminum,

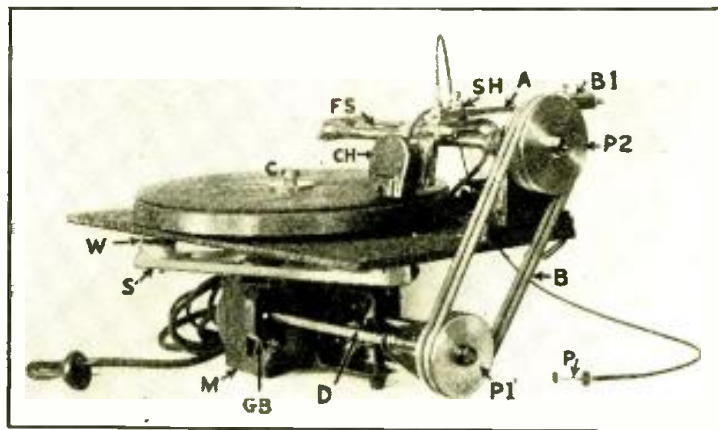

Fig. A

*Detail of the recording unit shown in Fig. B; it will operate on plain or grooved discs. A special recording head must be used for the latter. The plunger P is used to give great accuracy in raising and lowering the head. The components and their functions are described in the text.*

it can be used also for blank pregrooved records simply by adding an ordinary phonograph pick-up equipped with the proper weights. The turntable motor M is of the commercial phonograph type; slightly modified in order to drive the cutting head CH across the face of the record.

The gear box GB contains two helical

gears which transmit motion to the driving shaft D, which has a pulley mounted at one end of it. This pulley P1 drives, by means of the rubber belt B, the top pulley P2,

which is mounted on the feed screw FS. This feed screw has 64 threads to the inch; but the feed screw-turntable gear ratio is such that 96 lines to the inch are cut on the record. To give rigidity to the motor, the spider S upon which the motor is mounted is made very long; and it is separated from the mounting plate by means of rubber cushions or washers W, to prevent motor vibration being transmitted to the turntable.

A threaded clamp C is used to prevent slippage of the record during recording. This clamp is purposely made with a left-hand thread to offset any tendency of the turntable, driven in the right-hand direction by the motor, to loosen it.

The weight on the recording head can be varied by sliding along the weight-rod A, the weight B1. The rod also is movable, so that the weight can be made to hang directly over the cutting head if necessary. This head is guided across the face of the disc, by means of a half-threaded coupling which is kept in mesh with the feed-screw by means of a spring contained in the spring housing SH. A very unique feature of the apparatus is the plunger P.

The motor, although it has enough torque to make a twelve-inch record, has a difficult time starting with the cutting head on the disc. Now, by the use of the plunger P



Fig. B

*A studio-model recorder; the reproducing pick-up is at the left of turntable.*

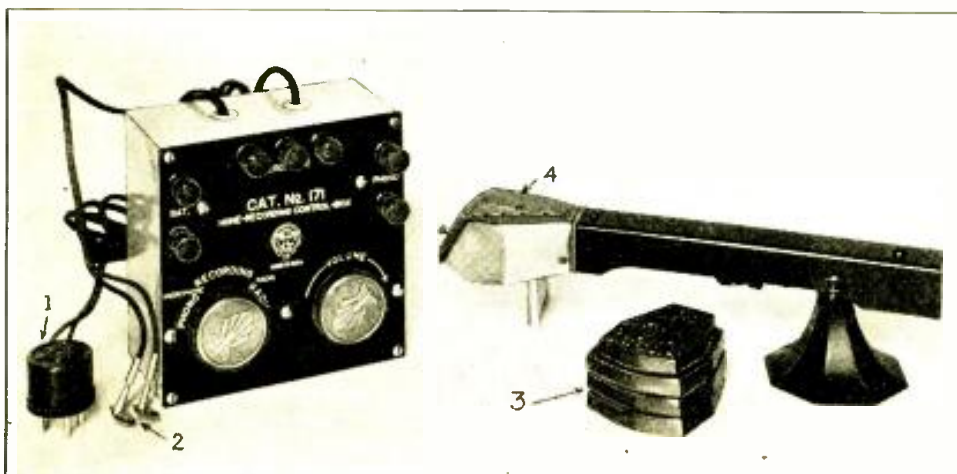

Fig. C

*This apparatus, with a microphone and its battery added, is designed for permanent attachment to a receiver, for recording and reproduction. Adapter 1 and lens 2 connect, respectively, at the detector and power stages. The pick-up-recorder 4 is loaded with the weights 3, as required.*

the following procedure is carried out: While the motor is at rest, the cutting head is placed at the "start to record" point on the blank record. The plunger is then pushed, and the cutting head now may be raised from the record by pushing in plunger P; after which the motor may be started. When it has reached normal recording speed, the plunger is released, thus replacing the recorder on the record.

This machine cuts a good, even groove with no apparent "line periodicity" (uneven spacing—not uncommon in some makes); and it is especially adaptable for studio work.

Fig. B shows the complete studio recording apparatus utilizing this machine. It must be remembered that excellent results are obtainable only when a good two-button microphone and a good three-stage transformer-

must be isolated in another room of the studio suite. (The design of this assembly is in accord with the specifications which appeared in the previous article, in which, particular attention should be given to Fig. 4, pg. 29.—Tech. Ed.)

**The Recordovox**

The Patent Model 171 "Recordovox," shown in Fig. C, is made especially for home recording, to use only pre-grooved records; this instrument does not record on non-grooved metal records. Besides making the records, it reproduces them as well; and, once this apparatus is connected to the radio receiver, it need never be removed.

In order to use the "Recordovox," a radio set, turntable and microphone are needed. To use a single-button microphone, only two connections are made, to the center post

The recording head is connected to the terminals marked "Phono." The five-prong adapter 1 (connected by a cord to the control box), is inserted in the detector socket of the radio set, and the detector tube is placed in the adapter. The single-prong adapters 2 (furnished with the instrument), are placed on the plate prongs of the two output tubes; which then are replaced in their sockets. The remaining cord from the control box plugs into the receptacles incorporated in these adapters. This completes the installation. For radio reception only, the selector switch is turned to "Radio," and the set tuned in the regular way; and to record a radio program the selector switch is set at the "Recording Radio" position.

The turntable motor is turned on, a home-recording needle is inserted into the recording head, and the latter is weighted with one or more of the weights, 3, (supplied with the kit.) The radio set is then tuned to the station whose program is desired for recording, making sure that the volume control is at a fairly high level. Best results, of course, will be obtained with all three of the weights; but, very often, the phonograph motors available do not have sufficient torque to pull the turntable around when the head is thus weighted, and a lesser number must be used.

When it is desired to make microphone recordings, the volume control of the radio set is turned to the position for minimum volume. (If a signal still is heard, the receiver must be detuned.) The selector switch on the control box is turned to "microphone recording," and (after the cutting head is set as described above), the apparatus is ready for the recording.

The microphone, if of the single-button type, should be held in a true vertical position and about one inch from the lips of the speaker, who should use a tone slightly louder than ordinary conversation. If squealing is noticed, the microphone should be kept away from the loud speaker. In

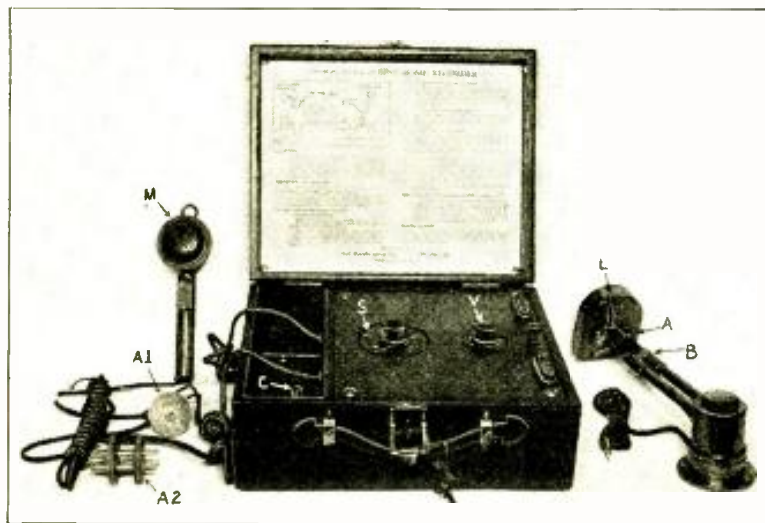

**Fig. D**

The Best Home Recorder; left, microphone M, with adapters A1 for connection to the input, and A2 (two plugs) for the output of set; C is a cap for use with a screen-grid detector; S, switch; V, volume control. The pick-up, at right, is described on page 118.

or resistance-coupled A. F. amplifier are used. The standard impedance of the cutting head is in the neighborhood of 4000 ohms; however, it is obtainable with a unit of any standard impedance.

The cabinet contains, for recording and playback, a complete amplifier and current-supply system, consisting of two stages of A. F. using type '27 tubes, and a power third stage using push-pull '45's; the rectifier is an '80. An indication of the sound level at which the recorder is working is given by a dynamic reproducer contained in the cabinet. The microphone, of course,

and either one of the outside posts marked "microphone"; and a 4½-volt "C" battery is connected to the posts marked "Batt." If a two-button microphone is used, connections are made to the three microphone binding posts; and a 6-volt battery is required.

**Fig. E**

Set-up of the new Presto home recording kit; shown in recording position.

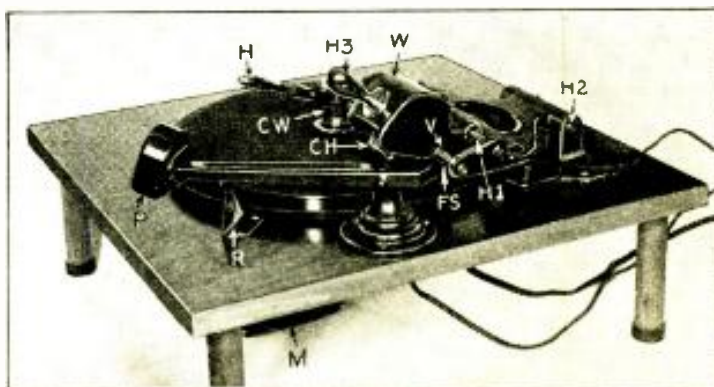

**Fig. F**  
The Presto recorder in the "change record" position; note that the cutting head swings loosely on its bar H1, so that it may be folded back.

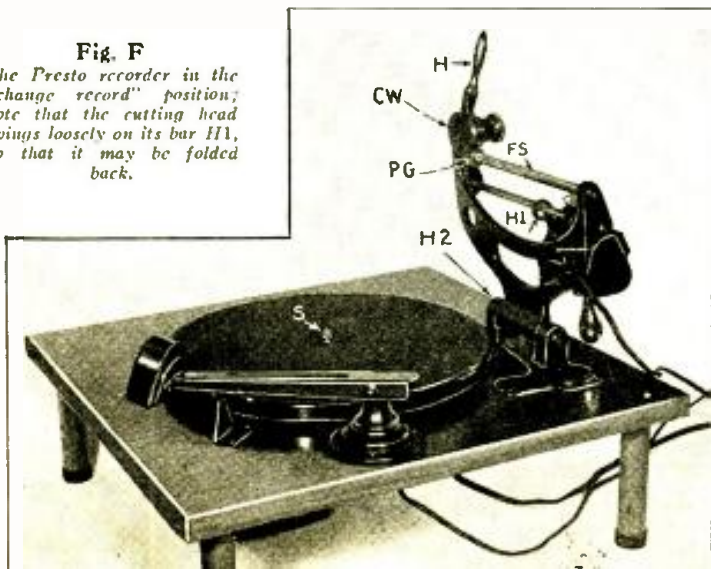

To reproduce, with the equipment shown, the cutting head is turned back on H1, and the pick-up P, here shown in its rest R, is placed on the record. CW is clamped to the motor's spindle S and drives the feed-screw FS.

fact, for best results, the microphone should be in a room separate from the radio set and with the intervening door closed.

On playback, the previous instructions for detuning the radio receiver and setting the volume control at minimum volume are followed; and the selector switch is set to the "Phono" position. The volume of the record reproduction is regulated by means of a knob on the control box.

(Continued on page 118)



# Operating Notes for Service Men

## Causes of "Fading" in Some Well-Known Receivers

By BERTRAM M. FREED

**B**Y now, it would seem, manufacturers of receiving sets should have discovered the weaknesses of various constituent parts used in their product, and have taken steps to substitute superior components. However, the Service Man is here, and his work has to be done.

One of the hardest tasks that befalls him in his daily routine is to trace the cause of "fading"; by which term is described both the gradual falling-off of volume, with slow recovery, and the sudden cutting of volume to just above a whisper, with resumption just as sudden. Such a complaint may be caused by a defect in, practically, any part in the whole receiver; and it is therefore very different to locate the fault. However, experience with the repeated failure of a definite part in a certain model of receiver helps to ease this task greatly. From time to time, the writer has described various causes of fading which he has experienced; here are others.

### Fading in Kolsters

In the Kolster "K43," all screen-grids receive the same voltage and are bypassed by an 0.6-mf. condenser; this capacity unit is one of two contained in an oblong metallic housing, and has a green lead which is connected to the "G" terminal of the second R.F. socket. (See Fig. 1.) This condenser is subject to open circuits, and to a change in its impedance also; thus causing fading of either type—gradual or sudden. Replacing this capacity with a 1/2- to 1-mf. unit, of good quality, will clear up this defect. (The common terminal lead of this block is black; and connected to the metal framework of the hum balancer.)

Another reason for the complaint of fading, in this model, lies in the volume control; this may be readily tested by pulling the control knob out and in several times, or by rotating the knob while pulling it

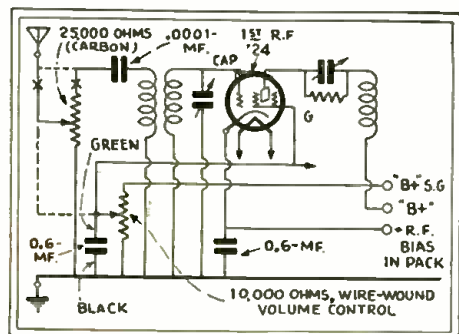
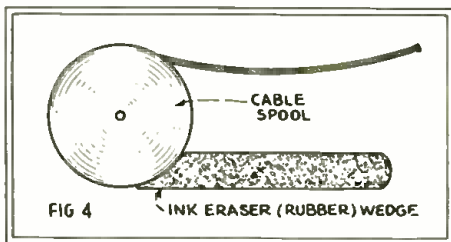

Fig. 1

An open screen-grid bypass may cause fading; as well as the antenna unit of a dual volume control. (Kolster "K43.")

out. The volume control, which is located at the rear of the chassis, and controlled by a long shaft, has two sections; one a wire-wound affair and the other a carbon-type. The latter is the cause of the trouble; the resistance element becomes caked and flaky and cracks, causing resistance variations and fading. This is a 25,000-ohm resistor, used as an antenna potentiometer; the 10,000-ohm wire-wound potentiometer controls the screen-grid voltage. Where to obtain an identical replacement unit might be a question; but this is not necessary. Remove the defective unit from the circuit, by disconnecting from the end of the resistance strip the lead to the .0001-mf. condenser; and connect this lead, instead of the potentiometer arm, to the antenna post. There will be little difference in the operation and effect of the volume control without this unit.



Another recommended addition for the Service Man's kit is an ink eraser; which will at times take the place of a third hand.

Incidentally, in this "K43" model, look for "floating" R.F. coils; these inductances may come loose from their supports and cause much annoyance. This is rare, however, but there will be no harm if the coils are tightened up a bit.

### R.F. Coil Grounded

A Brunswick "Model 22" was returned for fading, several times, to the shop of one of the largest servicing organizations in New York. Each time it had been placed on a "life test"; but nothing happened, and orders were given to take the chassis back to the owner's home and make every attempt to locate the trouble there.

After a great deal of trouble, the R.F. shield cans were removed to be certain that all was "O. K. under the tin." Then the input or first R.F. coil was found with one connecting lug so close to the chassis that the difference was not perceptible to the naked eye. To cause momentary or continued shorting and fading, vibration need not have been violent. This coil is wound on a very light form, to reduce losses, and it is very difficult to bend the lugs up out of the way for fear of snapping them off.

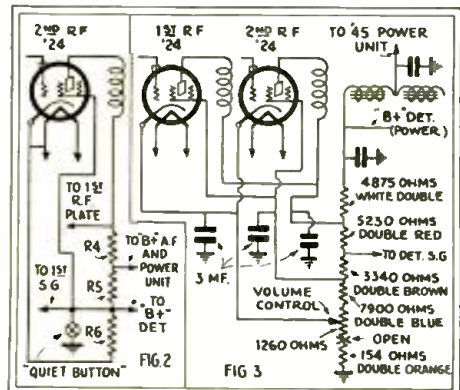

Left, voltage divider of the Colonial "33" and "34 A.C." R4, 11,000 ohms; R5, 60,000; R6, 50,000. Right, a reason for enormous cathode voltages (Majestic "131"-"132.")

Insulating them with ordinary tape, however, will do nicely and eliminate recurrence of the complaint. At the same time, examine the connections to the "local-distance" switch for corroded joints.

The tone control in this model is a Bradley unit. If the knob is not loose, yet can be rotated without any change in pitch, the bakelite gears within are stripped. Repair is hardly practicable, and the unit should be replaced.

### Unduly High Voltages

In the endeavor to deliver quick results, many Service Men make hasty repairs which, in certain cases, do more harm than good. For instance, in the Colonial "33" and "34" A.C. models, there is a three-section voltage divider (Fig. 2) which is often the cause of an inoperative receiver. The 60,000-ohm section is most apt to open, the 11,000-ohm slightly less so. Merely shorting the 60,000-ohm resistor, which cuts down the high voltage to between 100 and 70 for the screen-grids, will obtain reception, but seriously impair results and reproduction and ruin a pair of perfectly good '24 tubes; since it puts 200 volts on the screens and causes oscillation and general instability. Replace this section with another as near as possible to the proper value.

To those who have had any experience with the Majestic "131" or "132," it will be interesting to note that sometimes a reading of 300 volts will be obtained between the cathodes of the first and second R.F. tubes and the chassis. This has been encountered when the volume control has twisted around until the blue wire on one side had broken away. This is due to the loosening of the nut mounting this unit, which may take place after it has been in use for some time. (See Fig. 3.)

Installing a new drive-cable on a Bosch "48" is a simple job; the following is the procedure. Procure copper or phosphor-bronze cable of sufficient strength and weight; using too light a cable only invites more trouble. Remove the front plate, after taking off the tuning knobs. When the tuning scale and the old cable have been removed, loosen the set screw holding the threaded rear winding spool; fasten the new wire, soldering a loop around the screw, and tighten this again. Wind up the wire on a spool, pass it under the pulley and up. The delicate part of the operation comes at this point for, as soon as the shaft

or wire is released, the wire comes off the spool. If an ordinary, wedge-shaped rubber eraser is forced under the rear spool, after it has been wound (Fig. 4) the wire will remain in place; the shaft and spool will be unable to move, and both hands may be used to complete the job.

**Changing Filament Supply**

In the Freshman "2N" receiver, fading has often been traced to loose terminals and corroded connections in the power pack. Most frequently, it is the 1½-volt (26 filament) terminals which loosen; and a varying voltage will result. When working on these sets, it is best to remove the pack cover, and tighten these terminals with a heavy screwdriver, even though no trouble has been experienced here. If one of the 1½-volt terminals is open, it is not necessary, as a rule, to replace the power transformer or add an additional filament transformer; simply connect the leads, which ran to the open winding, to the other. Usually, enough current can be obtained in this manner to operate all '26 tubes properly. However, if the R.F. filaments are being heated from the audio winding, it will be necessary

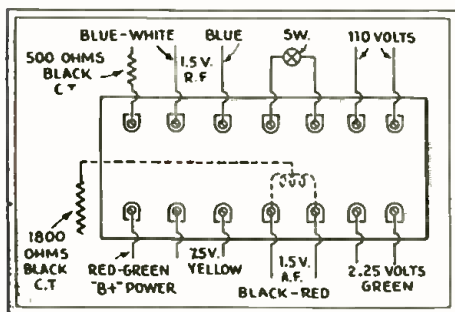

Fig. 5

You can switch tubes from one winding to another; but see that the biasing resistor has the proper value. (Freshman "2N.")

to change the biasing resistor. Remove the 1,800-ohm flexible resistor (Fig. 5) and replace it with the 500-ohm resistor used with the R.F. winding; since this resistor is now carrying the plate current of all four tubes, 1,800 ohms would put on them a bias much too high.

**Adjusting the Sonora Motorboard**

There have been sold many Sonora combination sets, using the Loftin-White amplifier and a special series-wound phonograph motor. The latter makes use of an unusual stopping arrangement, which sometimes gets out of order; it works in conjunction with the pickup arm. When the arm is swung away from the turntable, as far as it will go, the switch is closed, and the motor will function. At the end of each record, whether the eccentric groove is present or not, the table will turn a number of times and then stop; this is due to the opening of the switch and the application of the automatic brake lever. If the turntable does not stop when the record is finished, or if it stops before the record is ended, it will be necessary to remove the motor board. Disconnect all wires running to it; that is, the A.C. motor plug, the ground wire, and the three leads from the pickup to the connection strip at the rear of the cabinet. Lay the motor board in a convenient position, and measure the distance from the center of the turn-

table's spindle to the center of the mounting screw of the pickup arm. This should be exactly 9 inches; and the measurement must be made accurately, for a discrepancy of a fraction of an inch will cause one of the complaints above mentioned. To permit of adjustment, the mounting holes for all parts have purposely been made large. It will be necessary to check the alignment of the centers of lever arms and motors; these must be in a straight line—(M), (C), (P), (W) (See Fig. 6.) Loosen the screws, bring the points into a straight line and see that the centers of (M) and (W) are exactly 9.00 inches apart. It is important that the pin (P) shall slide freely along the long edge of the lever (L). The screws may then be tightened, and the motor board replaced and reconnected.

**Give the Receiver Air!**

Recently a discussion took place, among a group of Service Men, why screen-grid tubes "go west" much more frequently and quickly in some receivers than in others. The argument was advanced that the heating, and the ventilation of the tubes have much to do with this; that when they reach a certain temperature, their efficiency will be reduced and fading caused until the tubes cool to their normal temperature. After this, the cycle would be repeated.

With the idea of making a test, some of the worst offenders (such as the Colonial "32A.C.", which has double shielding for the screen-grid tubes; the Fada "32, 44, 46" series, and others) were set up, and left on "life test" with sets of perfect tubes in each. It was considered that placement of the sets might have much to do in the case. Some of the test sets were placed in advantageous positions, to secure high ventilation, and others as they would be ordinarily in the home.

The tests were not carried on too scientifically but, after some weeks of trial, it was found that those which did not secure the greater degree of ventilation contained one or more fading tubes, and that effect did occur. The Colonial set which was operated with only the inner set of shield cans showed four perfect '24s, while the other contained two "faders." Each set of similar make was operated under the same filament voltages.

Which would suggest that, when installing a receiver, it might be well to have its ventilation in mind and that, if shields do not provide sufficient openings to dissipate the heat the tubes generate, holes should be made or enlarged.

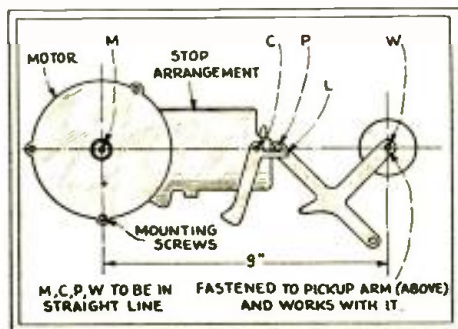

Fig. 6

The automatic stop of the Sonora phonograph combination must be correctly lined up, to stop the motor at the right time.

# The Open Forum

**THEY GET WHAT THEY PAY FOR**  
*Editor, RADIO-CRAFT:*

In your June issue there is an article by Mr. H. A. Deal, under "Hints for Radio Manufacturers," in regard to heating of power transformers and suggesting that more material be used. He is right; but the manufacturer of transformers who increased the size of his transformers, in order to give better regulation and prevent heating, could not sell his product. He would be compelled to increase his price and, if there was \$1.00 difference in price, the buyer would take the cheaper. When people learn that there is the same difference in the quality of two transformers of the same rating as with other articles of merchandise, then it can be done; but, until that time, the manufacturer who attempts to sell a good transformer at a higher price than asked for a light-weight article is courting financial disaster.

From our experience as manufacturers of transformers for amateur transmitting and broadcasting stations, we know this to be true; with few exceptions, the average buyer of transformers knows nothing whatever about a transformer. Good regulation, freedom from heating, and high-grade insulation mean nothing to them.

There is another excellent article on the same page of the June issue, by Mr. Harry Georges, in regard to resistors. We endorse his statement that "resistor bargains simply do not exist," and will add that there is no such device as a bargain transformer.

When the buyer of radio parts is willing to pay a reasonable price for an article of quality, rather than demand something at a low price, he will find all reputable manufacturers ready to supply him.

NAT G. SCOTT,  
*The Scott Coil & Transformer Co.,  
Myrtle, Mississippi.*

**WHERE SERVICE MEN COOPERATE**

*Editor, RADIO-CRAFT:*

I am a constant reader of RADIO-CRAFT, and think a great deal of your publication—in fact all the Gernsback Publications—but it seems to me that since the beginning of the current year RADIO-CRAFT has been getting more and more lax in its descriptions of instruments and the diagrams of same. For instance; (March) tube checker by Campbell, one lead omitted; (April) Supreme tube checker, no values given—making it useless to any Service Man; (June) Supreme oscillator, value of inductance given as 6.2 millihenries—an impossibility in R. F. tuned inductance. Also, no value given for the R. F. chokes.

I believe there are other readers who will appreciate a more thorough description of articles and diagrams printed in RADIO-CRAFT.

Allow me to comment on Mr. H. H. Rabe's letter; in the territory in which I  
*(Continued on page 112)*







**BOSCH MODELS 60 AND 61 (Automatic Volume Control)**

The automatic volume control circuit functions in the following manner. When the signal being received increases in volume (as when tuning in) a signal of increased strength is applied to the detector tube V4; and thus to the control-grid of screen-grid automatic volume control tube V8. This increase in the control-grid potential of V8 results in increased plate current, which must pass through resistor R11. The voltage drop across this resistor, which also is in the cathode circuit of the R.F. amplifier tubes V1 and V2, therefore increases; and this increased bias is effective on the control-grid of V1, and V2, causing a reduction in volume. This increase or decrease in cathode current is indicated on the meter M in the portion of the cathode circuit common to V1 and V2. (Motion to the right indicates a reduction in current; since the meter is wired to work "backward" to standard test meters).

Note that the filament, cathode, and control- and screen-grid potentials of V1 and V2 are at approximately the same potential above ground as the plate of V8. Therefore, particular attention should be given to the possibility of a short or leakage to ground through any portion of the wiring or the associated apparatus. A suitable tube to use as V8 may be selected in the following manner: Note the meter indication with the set turned on, but detuned, and tube V8 out of the socket. The reading should be between 3½ and 5 divisions. Now insert V8; the needle should then remain stationary if the tube is suitable.

The phosphor-bronze drive-cable may be replaced in the following manner: turn the tuning condenser gang to the zero position (plates fully open), and place one of the cable loops over the pin at the top right-hand side of the large drive drum. Lead the cable along the groove and down to the small grooved drum; and turn the condenser gang to the "100" position. Next, start the cable at the center groove of the small drum and wind on 6½ turns in a clockwise direction (to the right); winding toward the front of the receiver, bringing the belt up and over the idler pulley. Follow down the groove of the large drum and hook the second loop over the drum tension spring; which is conveniently pulled into position by catching a wire or cord in the hook of the spring. The final operation is to reset the dial; by loosening the small gear on the knob shaft; turning the shaft to the left as far as it will go; setting the dial against the stop at the "100" position; and re-tightening the small gear.

Two cables, terminating in plugs, connect the receiver's chassis to the power pack and power audio chassis. It is important to plug the left cable connection into the left receptacle, and the right-hand connection into the right-hand receptacle; so that the two cables do not cross. The dynamic reproduced in the "Model 60" receiver is provided with a copper shield, between its core and the field coil, which prevents hum induction between this coil and the voice coil. The field coil has a resistance of 2,000 ohms; and the voice coil of 10 ohms, approximately. Four strips of .01-in. paper may be used as gap gauges. The brown and red leads connect to the terminals marked "field coil"; and the black lead to the terminal marked "V."

The "Model 61" receiver has a chassis designed for 25-cycle operation; the only difference being in the power transformer and the increased filter capacity.

A letter following the numerals indicates the cabinet style.

is as follows: 250 ohms, white; 500, yellow; 900, black-brown; 1,000, white-red; 2,000, brown-yellow; 5,000, black-yellow; 10,000, blue-yellow; 20,000, green-yellow; 25,000, blue; 50,000, green-white; 0.1-meg., blue-white; 0.25-meg., brown; 0.5-meg., gray; 1 meg., black; 2 megs., black-white.

Average operating voltages for the "60" are as follows. Filament potentials: V1, V2, V6, V7, 2.4 volts; V3, V4, V5, V8, 2.3 volts; V9, 5 volts. Plate potentials: V1, 170 volts; V2, 180 volts; V3, 185 volts; V4, 60 volts; V5, 150 volts; V6, V7, 250 volts; V8, 30 volts. Plate currents: V1, V2, 3 ma.; V3, 2 ma.; V4, 0.1-ma.; V5, 6 ma.; V6, V7, 30 ma.; V8, 0.2-ma.\*. Screen-grid potentials: V1, 70 volts; V2, 80 volts; V3, 85 volts; V4, 10 volts; V8, 20 volts\*. Control-grid potentials: V1, V2, 2 volts; V3, 1.5 volts; V4, 1 volt\*; V5, 0.1-volt\*; V6, V7, 50 volts; V8, 0.2-volt\*.

These readings are made with the volume control full on. These figures followed by asterisks are measured through resistors of high value and, therefore, the reading will vary with the particular type of testing instrument used.

The trimmer condensers are located on the condenser gang. The antenna coupling condenser C1A is adjusted from the side of the chassis, when the set is installed, in the following manner: tune in a somewhat weak station at some point between 40 and 60 on the dial; reduce the volume until the station can be barely heard; and then turn the adjustment knob of C1A until the signal is received with maximum volume.

The trimmer condensers may be adjusted for maximum motion (to the right) of the tuning meter M.

The resistor color code used in this receiver is as follows:

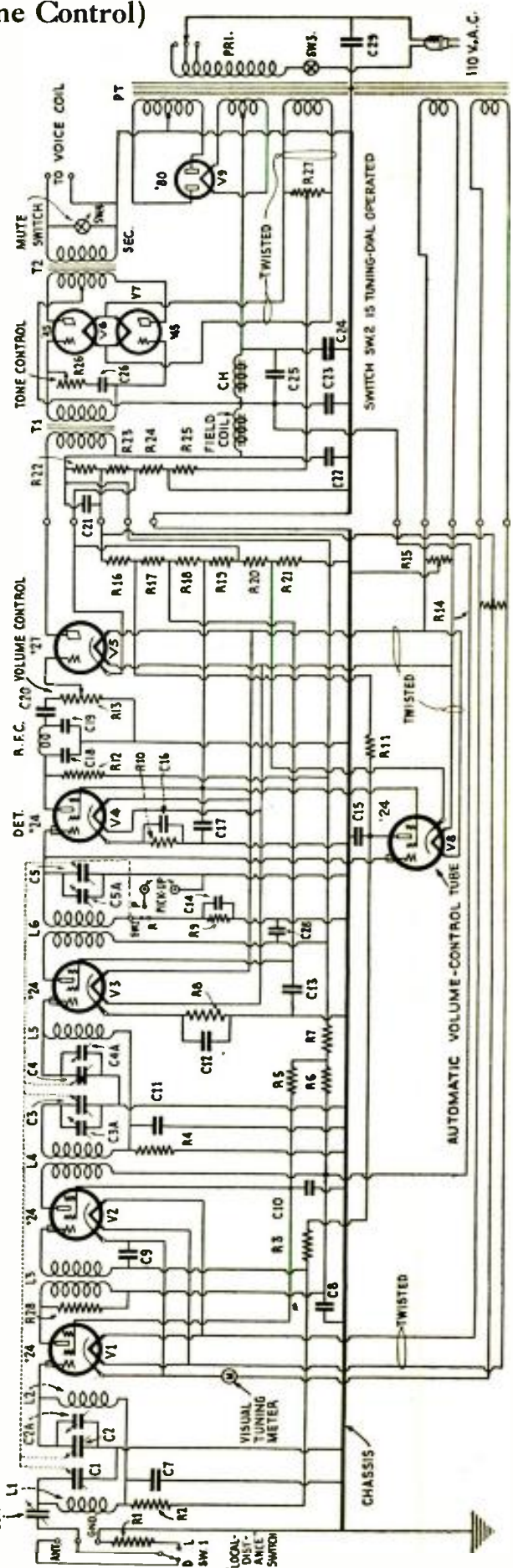



# The Favorite Testing Equipment of Service Men

And Practical Methods of Facilitating Their Work

## A PENTODE TESTING ADAPTER

By B. T. Stubbs

**B**ECAUSE of its unusual switching facilities, the Supreme "Model 90" set analyzer will handle the new pentode tubes without adapters. But, since all readings are taken from the cathode prong, you must read the cathode (space-charge) voltage first; then, to get the plate voltage, you must add the space-charge voltage to the plate-voltage reading, to get the true value. Also, you must subtract the space-charge voltage reading from the grid-bias reading to get the true grid bias. Then, too, you must be careful to have the "UX-Heater" toggle switch on the "Heater" position (right), to avoid shorting out the high space-charge potential.

The "Model 90" has a circuit, made for the R. F. pentode, with a connection coming out on the analyzer plug, and a pin jack on the analyzer. There are two push buttons, for reading the space-charge voltage, and the space-charge current. By means of two simple adapters the space-charge grid of the output pentode is brought out to this circuit. The space-charge voltage is then read by the "Sp. Ch. Voltage" button (upper left), and the space-charge current by the "Sp. Ch. Current" button (upper right). You could not read the space-charge current in the other way.

One adapter consists (A) of a five-prong plug with a UX socket, which receives the regular analyzer plug. The cathode prong of the socket is brought out on the side to a small bolt which goes to the pentode connection on the analyzer plug.

The other adapter (B) consists of a UX plug with a five-prong socket, the cathode

contact of which is brought out in the same way as the other; connection, on the side of the adapter, ending in a pin to be plugged into the "Sp. Ch. Grid" pin jack. The pentode tube fits into the five-prong socket of this adapter.

The readings are taken by depressing the "Sp. Ch. Voltage" and "Sp. Ch. Current" buttons, with the scale selector set at the correct scale. There is no danger of shorting out the space-charge potential. These adapters were made from UX and UY tube bases and UX and UY subpanel sockets.

(It is interesting to note that Mr. Stubbs developed this along precisely the lines of an adapter which the manufacturer of the

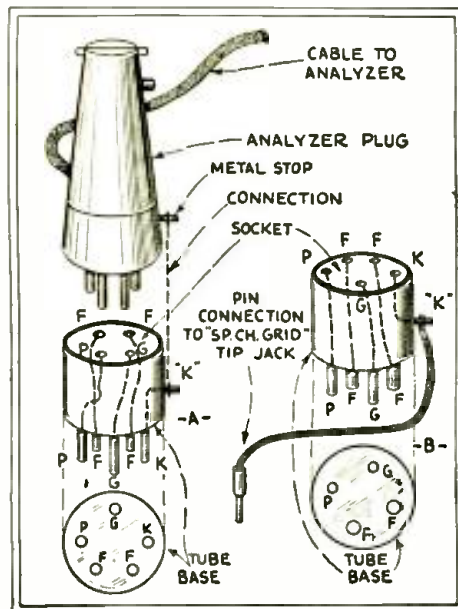

*Mr. Stubbs makes pentode tests conveniently, saving time and arithmetic, with these adapter plugs, which are suited to the various types of new tubes.*

*Mr. Hartzell built this very attractive all-metal testing bench for the Central Radio Company of Dayton, Ohio. Neat, completely contained equipment such as this is not only a pleasure to work with; but deserves advertising to consumers who will better appreciate that radio servicing is now out of the junk-box stage, and become a scientific profession.*



*A high-grade meter deserves to be handled with care; and a shockproof container like this is desirable.*

set analyzer was also producing for the use of its owners. The circuit of the "Model 90" was printed in the January, 1931, issue of RADIO-CRAFT.—Editor.)

## SHOCKPROOF ANALYZER CASE

By John J. Nothelfer

**O**N several occasions, while about to test tubes or radio set in a customer's home, I have noted that the analyzer had one or more circuits "on the bum." After taking it apart, I found the wire connections becoming loose. This happened several times, and I was unable to account for it. Recently, the needle shaft jumped off the pivot of one of the meters. I knew then what had caused all my past troubles; the jarring and banging of the service car was the cause.

I eliminated this annoyance by building a felt-lined box in which to keep the meter. The box was made two inches larger on each side than the outside dimensions of the analyzer. Thick, heavy felt was then nailed to the inside walls of the box, in which the meter was then carried to and fro—and the annoyance ceased.

The box may be fastened in the service car or truck. A top with a lock may be used to prevent theft.

## AN ATTRACTIVE TEST BENCH

By Ogden D. Hartzell

**T**HE testing bench illustrated in the accompanying photograph was designed and built by myself for our service department. It contains a phonograph pickup and turntable, a dynamic speaker, a pushpull power amplifier; furnishing current also, for testing battery sets, to binding posts on panel. These voltages range from "C-40" to "B+ 180."

There is also an "A" battery eliminator, with a voltmeter across output voltage; and an oscillator with resonance meter. The row of jacks on the panel, with switches directly beneath, makes it possible to get any speaker connections needed.

The speaker is used on the amplifier; it can be connected to any set and also in

(Continued on page 114)

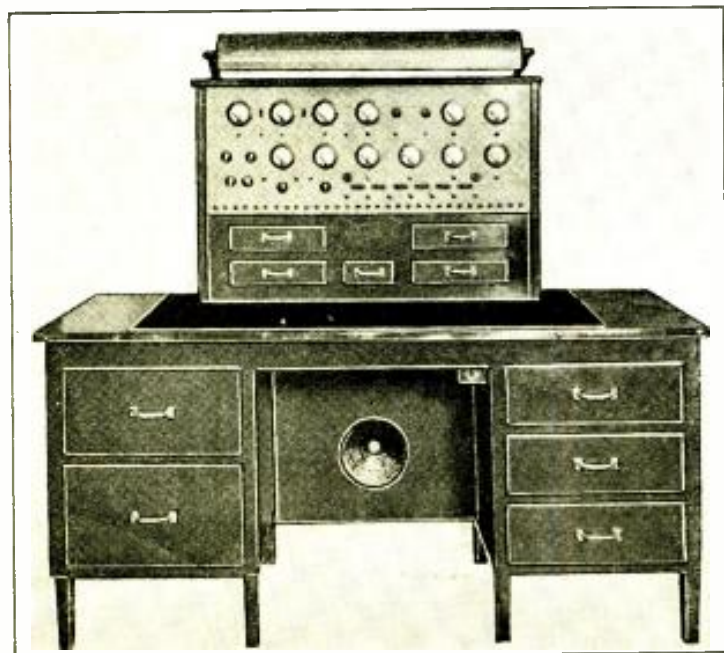

# Service Men's Notebooks

*A few leaves from the experiences of our readers. What have you found in your daily rounds?*

## ELIMINATION OF HUM

By Fred Erdos

MANY hours have been spent in reducing hum in receivers; but one in particular took extreme patience. Every part tested correct; until, after hours of work, it was found that the insulating washer of the dial light had been worn down until one terminal of the light touched the grounded chassis. This threw the R.F. and detector circuits out of balance, and excessive hum resulted.

Another frequent source of hum is the lack of a good ground connection, especially when the set has been installed by its owner, who fails to realize the importance of this. Often the ground is omitted entirely. The noticeable hum which results is eliminated by finding a good ground.

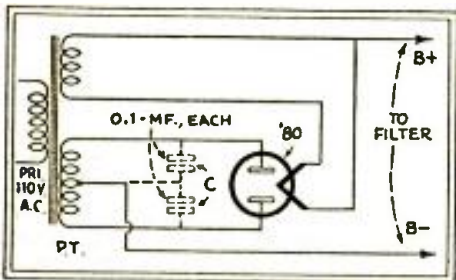

Fig. A

Some sets incorporate this hum filter; where it has been omitted, to save cost, the Service Man may sell another extra.

The use of two 0.1-mf. condensers across the high-voltage leads to the '80 rectifier tube, as sketched, will eliminate much hum and noise. Very few packs are equipped with these condensers.

## MISCELLANEOUS SERVICE NOTES

By E. C. Woodworth

FADING of a very puzzling nature in the Zenith "Model 52" may be cleared up by insulating the dial-light bracket at the point where it enters the dial. In this receiver an unusual balancing point is used—203 meters. In a screen-grid set of this model, it has been found that a microphonic '24 in the detector socket caused a noticeable hum, similar to that from a faulty bypass condenser.

The Steinite "Model 70" and "80" ground the rotors of the tuning condensers by a wiping contact which, after a short time, may develop a very annoying, scratchy sound when the dial is turned. This may be entirely done away with by slightly bending up the ends of the copper springs and tightening them very firmly.

The Kolster models "K20-24" (inclusive) sometimes develop a motorboating noise which may be done away with by removing the small condenser from the R.F. grid suppressor.

On automotive sets, a very annoying interference may persist until the ignition coil is removed, and all points where it

touches the frame are carefully cleaned with a file to make a good ground.

In replacing drive cords on the dials of various sets, it will be found that bronze fish line is very effective, and it is not expensive.

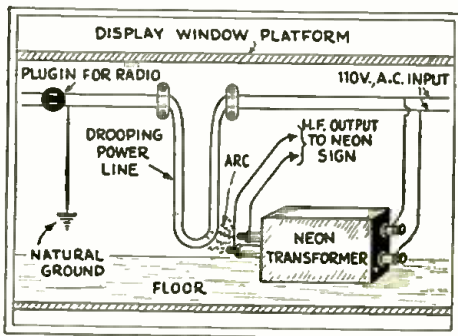

Fig. B

Interference keeps bobbing up from all directions. Here is a case where it was invited.

## ANOTHER CAUSE OF NOISE

By Rolf N. Jensen

NOISES have a great many queer reasons: a few days ago I came upon one which had been a bugaboo to several other Service Men, and I am glad to impart the reason to others whom it may help. The diagram will explain.

The set, located in a downtown restaurant, was picking up noise that almost drowned out the music, and the theatre across the street had been getting all the blame. It took current from the same light-line as the transformer feeding a neon lamp, and the twisted cord had been carelessly allowed to lie across the line feeding high-frequency current to the neon tubes. The result was a steady arc, since one side of the light-line is grounded.

## NO POWER TUBE BIAS

By Jerry Davidson

AFTER checking voltages on a Bremer-Tully, and finding nearly all of them correct, and all tubes good, another Service Man called me in. As the enclosed diagram shows, the speaker field is between ground and the '80 plate winding; the speaker could be disconnected without changing the set voltages greatly, but neither of the '45's had a grid voltage. The center tap of the '80 was found to be grounded internally; a new power transformer corrected this trouble.

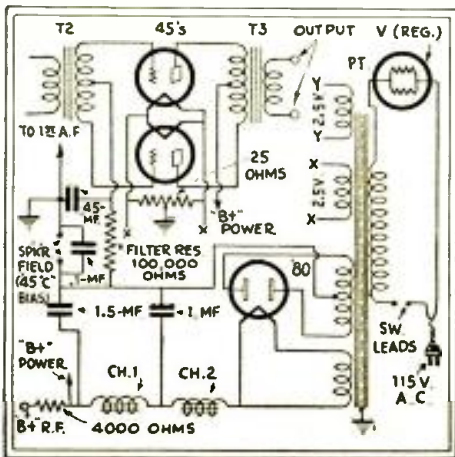

Fig. C

With the increasing vogue of using the field coil of a dynamic to serve as a voltage-reducing resistor, complications are to be looked for.

# Hints for Radio Manufacturers

## AN EXTRA RECEPTACLE

OFTEN a customer asks me: "Why not incorporate an extra socket, similar to that for a voltage regulator, in some accessible part of the chassis, so that a lamp may be plugged in?" There are many types of lamps—"shadow lamps" for instance—which should be used decoratively with the radio; but the extension on them is not nearly as long as that used with the receiver, and it is very difficult to find a receptacle for the lamp. Then, too, some people do not wish the extra wires trailing about the place. I hope manufacturers can do something about this without much expenditure; sales and service will profit. (I have built-in several such receptacles myself with good results.)

LEIGHTON ROSS,  
#53 William St., Belleville,  
Ontario, Canada.

## FOR TWO-VOLT TUBE TESTS

MY suggestion, to some manufacturer of sockets and adapters, is to make an adapter to be placed in the 2½-volt socket of the tube testers that are now in use, to enable Service Men to test the new '30, '31, and '32 types. The resistor necessary to drop the extra half volt could be built into the adapter. That a definite need for such a device exists was proved to the writer when he visited seven radio stores and was told, in each case that they had no equipment to make this test.

An A.C. ammeter would also be handy, in testing the outputs of filament transformers, transformer line draws, etc.

Experiment has proved that coil shields made of metal screen give sharper tuning than solid sheet metal, so why not manufacture these?

VAN RICHARDSON,  
5216 Proctor Ave., Oakland, Calif.

## AN ALL-WAVE MIDGET

WHY not build a midget receiver with a short-wave combination? This would be very convenient, and a lot of radio fans would appreciate it; because they could listen to short waves, by throwing a switch or so, and then get what they want on the broadcast band. I think a set of this kind would go over great with the public, and afford a great opportunity for some radio manufacturer to sell something that is new. That is what they all want now.

ELNAR NELSON,  
Box 467, Burlington, Wash.

## KEEP OUT THE DUST

DUST-PROOF construction of the neutralizing and aligning condensers might be accomplished by encasing them in bakelite cases, similar to that of the X-L Variocap. This would add greatly to their efficiency and the permanence of adjustment.

DALTON NEWBERRY,  
R. R. 1, Port Haney, B. C., Canada.  
(Continued on page 114)



*Improved -  
April 1931 - Page 105*

# The RADIO-CRAFT "Pentode Portable"

*The lightest, smallest set giving loud-speaker volume on batteries*

VACATION is once more at hand and it's time to hunt up the old soldering iron and build that portable set you have been longing for. Never before has it been possible to throw together a few parts and, in an hour's time, complete a practical portable set of such small size and weight yet so large a power output. Now, however, this is made possible—with the arrival of the new battery-operated pentode—known as the type 33. The trend in midget set design has been toward smaller and simpler apparatus, creating a demand for tubes capable of higher "gain" or amplification, so that fewer would be needed in the set. While formerly several tubes requiring heavy batteries of large capacity were employed in portables to obtain loud-speaker volume, now the pentode with its loud-speaker output can be used alone with a minimum of battery space and weight.

In the set illustrated, only two tubes are employed: a type WX-12 ("general purpose") and a type 33 audio pentode. The reason for this particular combination will be pointed out later. The carrying case is that belonging to a small portable typewriter; but any suitable box may be employed, or one can be made especially for the purpose. The folding loud speaker is built into the cover. One dry cell supplies the filament voltage; while four of the smallest sized 22½-volt "B" batteries provide the plate potential.

The circuit is a simple regenerative one, employing one of the small three-circuit tuners so popular a few years ago. While the tone quality is not comparable with that of the modern receiver, with dynamic reproducer and power amplifier, it is equal to that obtained from a small portable phonograph; and on locals, and for distances up to a thousand miles, the volume is loud enough for filling a large room.

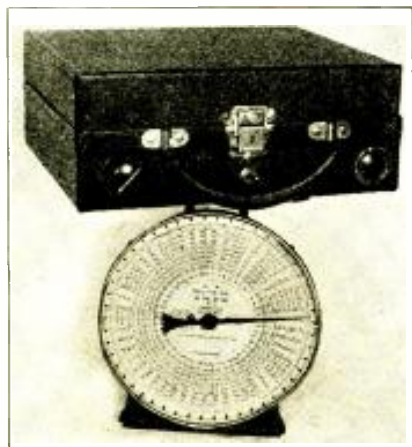

Fig. B

*Eight, twelve pounds, complete with batteries. Only the control knobs and filament switch are external*

### Experimental Tests

Before building the set illustrated, the pentode was connected up as a regenerative detector and its output tested with a loud speaker. On local reception, the volume was sufficient to operate the speaker, but on distant reception it was very poor—the pentode is not a very sensitive detector. For this reason, the WX-12 was selected for the detector, and its output fed into the pentode,

**R**ADIO-CRAFT this month leads with what is possibly the lightest and most compact portable loud-speaker set ever offered to the huilder. Constructed by RADIO-CRAFT's technical staff, and built in RADIO-CRAFT's laboratories, it presents a number of novel points, making it very desirable, chiefly due to its ease and simplicity of construction.

On local stations—New York—the volume was sufficient to fill a large room. On distant stations, such as Pittsburgh, Cleveland, Boston, it is necessary to use headphones unless you are satisfied with the weak volume which issues from the loud-speaker. All tests were made with a 30-foot aerial, and with an ordinary ground.

In our next issue, we will present a companion set to the present one, power-operated, and which can be plugged into any 110-volt A.C. line. We will be glad to hear from our readers who have built this interesting set, and pleased to receive their comments.

with the result that the set now is good on both local and distant reception. The WX-12 tube was selected, not only because it is a good detector, but also because its required filament potential (1.1 volts, requiring only one "A" cell) fits in with the design of the set.

It is true that the present standard rating of the pentode is:

Filament .....	2 Volts
Plate .....	135 Volts
Screen-grid .....	135 Volts
Control-grid.....	13.5 Volts (negative)

whereas, we are using it with a filament potential of 1½ volts, a plate potential of 90 volts with a 9 volt control-grid potential. While this is not according to Hoyle, the set works and proves very efficient. Furthermore, as the lower operating filament voltage causes less drain on the "A" supply, it will last longer. At normal 2-volt rating the filament current is 0.26-ampere. The



Fig. A

*The "Pentode Portable" with all its batteries fits into this small typewriter case. Observe the folding speaker.*

WX-12 draws a filament current of 0.25-ampere at 1.1 volt—making the total drain a little less than ½-ampere from the dry cell.

Fig. 1 shows the final schematic circuit. The three-circuit tuner (comprising the primary, secondary and tickler coils L<sub>1</sub>, L<sub>1</sub>, L<sub>2</sub>, respectively) has the secondary L<sub>1</sub> tuned by the .00035-mf. midget variable condenser C<sub>3</sub>; this covers the broadcast band. The grid condenser C<sub>1</sub> has a capacity of .00025-mf. and is shunted by the grid leak R of 2 megohms. R<sub>1</sub> is a fixed filament resistor of 1.5 ohms. An Amperite or filament rheostat may be used, or a fixed resistor may be used, or a fixed resistor with an adjustable contact.

The bypass condenser C<sub>2</sub>, which shunts the audio transformer T, has a capacity of .0005-mf. The "A," "B" and "C" voltages are indicated on the sketch. The loud-speaker unit L.S. is of the horn type and should have a low impedance, in the order of 7500 ohms; although any good horn unit may be used.

### Parts Required for the "Pentode"

Many of the parts required to build the portable receiver can be obtained from some old set or from the scrap box. Aside from the tubes and batteries, there will be little expenditure of money, and the entire outfit can be made for a few dollars. It is not necessary to use the exact parts specified as others will do and they can be arranged in the case in any convenient order.

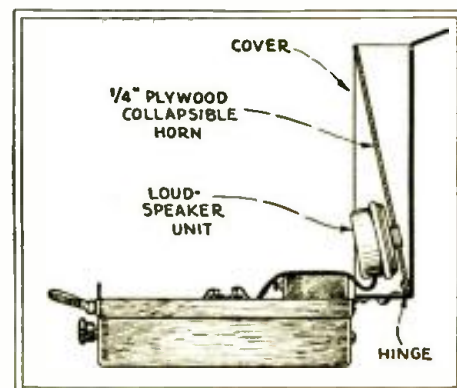

Fig. 3

*Note how the air column opens out when the case is opened; the unit is then taken from its clips and inserted in proper position*

**List of Parts**

- One "Corona" typewriter carrying case, 10<sup>3</sup>/<sub>4</sub> x 9<sup>1</sup>/<sub>4</sub> x 4 inches deep (inside dimensions);
- One Gen-Win 3-circuit tuner (L, L1, L2);
- One Hammarlund .00035-mf. midget variable condenser (C3);
- One Polymet .00025-mf. grid condenser (C1);
- One Polymet .0005-mf. bypass condenser (C2);
- One Lynch 2-meg. pigtail-type grid leak (R);
- One Carter 1.5-ohm resistor (R1);
- One Radio Trading Co. "replacement"-type A.F. transformer (T);
- Two Burgess 3-cell flashlight batteries ("C");
- One Everbest or Burgess 1.5-volt dry cell ("A");

the insulating shield of the batteries and the cell; otherwise a short-circuit would result. —*Tech. Ed.*) The four binding posts, for aerial, ground, and loud speaker, are mounted on a bakelite strip 3/16 by 5/8 by 1/4 in. which is attached to the case with two angle brackets. The tube sockets are mounted on the sides of the case as shown.

After all of the parts are mounted, the wiring may be started. It is easier to leave all the batteries out, until the other wiring is completed and then install the batteries. The entire job should not take more than half an hour.

**Novel Loud Speaker**

The loud speaker used in this set is somewhat novel. While not of the best design from an acoustical standpoint, it works very

well and occupies little space. The horn structure is shown in Fig. 3. A piece of 1/2-inch plywood, which will fit snugly within the cover, is hinged to it as shown. Near the hinged side is bored a hole (X, Fig. C) to receive the throat of the horn-type unit L.S. When inside the hinged portion swings out to the position shown, forming one side of the horn. When not in use, the unit is removed and placed in a metal clamp at the bottom of the case; the hinged portion is pushed in and the cover closed, as shown in Fig. B; making a compact outfit about 4 1/2" by 10" by 12" overall and weighing less than 1 1/2 pounds!

For the ground connection, it is necessary to provide a wire lead which, by means of a spring clip on the free end, may be attached to any large metal object or network, such as grounded pipes or a metallic framework.

For the aerial, a 50-foot length of insulated flexible wire is suggested. This may be suspended temporarily in the room, or on a tree if used outside; or, like the ground wire, it may be connected to some convenient metal object, such as a fence wire, telephone line or lighting socket. A mica-dielectric fixed condenser of about .00025-mf. capacity must be connected in series with the aerial when so used, or the circuit will not oscillate and the line will be grounded.

To tune in, turn the tickler knob so that the circuit oscillates, and then turn the tuning dial until a heterodyne squeal of the station is heard. Then slowly turn the tickler back changing the tuning slightly (if necessary) with the other hand, until the station is clearly heard. On locals, it is not necessary to make the circuit oscillate; for the stations can be heard without first bringing in the heterodyne whistle.

Because of the exceptional simplicity, sensitivity, volume and portability of the "Radio-Craft Pentode Portable," it is possible for set builders to reap a harvest, even in these times, by building around this fundamental design, small-space receivers for campers, tourists, vacationists and travelers of almost every type. It is expected that constructors will adapt available material to this circuit, and modify it to suit their own preferences and local conditions.

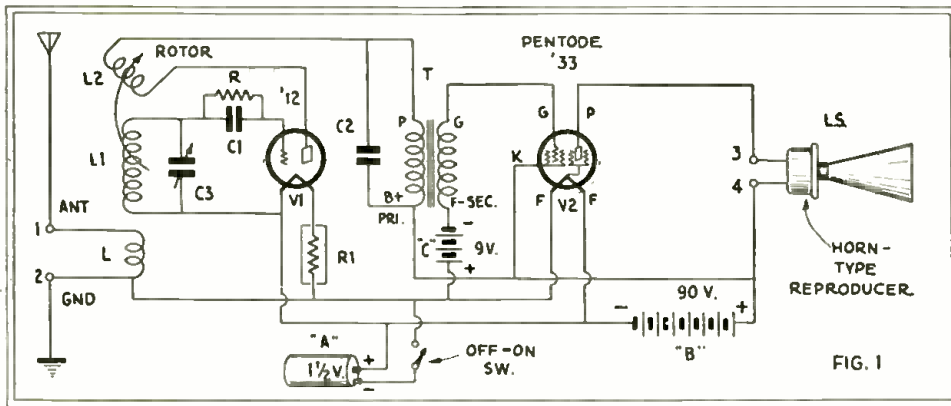

**Fig. 1 (above)**

The simple circuit of the "Pentode Portable"; LS should have an impedance of 7,000 to 8,000 ohms.

- Four Burgess 22 1/2-volt batteries ("B");
- One Utah horn-type magnetic loud speaker unit (L.S.);
- One Pilot UX-type socket (for V1);
- One Pilot UY-type socket (for V2);
- One RCA type WX-12 tube, 1.1-volt filament (V1);
- One Cable or Cunningham type '33 pentode tube (V2);
- Four binding posts, with bakelite strip and brackets (1, 2, 3, 4);
- One filament switch (Sw);
- Miscellaneous screws, wire, soldering lugs, etc.

If the specified typewriter carrying case cannot be obtained, it is well first to procure all of the parts, lay them out in the positions shown in Figs. C and 2, and measure the overall space they occupy. Then, a case that will fit may be constructed out of plywood. In this way, if there are used other parts than those specified, of different size and shape, the arrangement of mounting and size of case may be altered to suit. In a set of this type the layout of parts is not very important; and shielding is not essential, because no stage of R.F. amplification is employed.

The reproduced photographs, Figs. A, B and C, and Fig. 2, show the general layout. The parts are mounted directly on the case; with the tickler and tuning condenser knobs, and the filament switch, on the handle side, or top (when closed), as shown. The batteries and dry cell are securely fastened to the bottom of the case by means of a thin strip of brass bent around them and secured at each end to the case with small wood screws. (Be careful to avoid cutting through

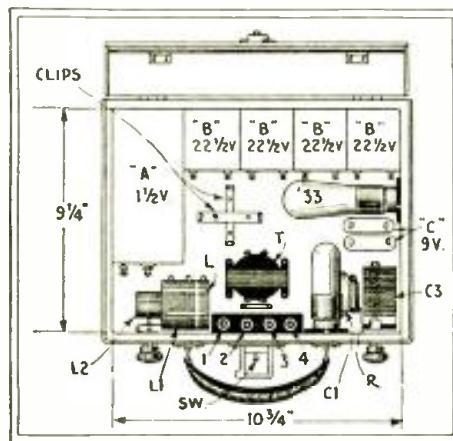
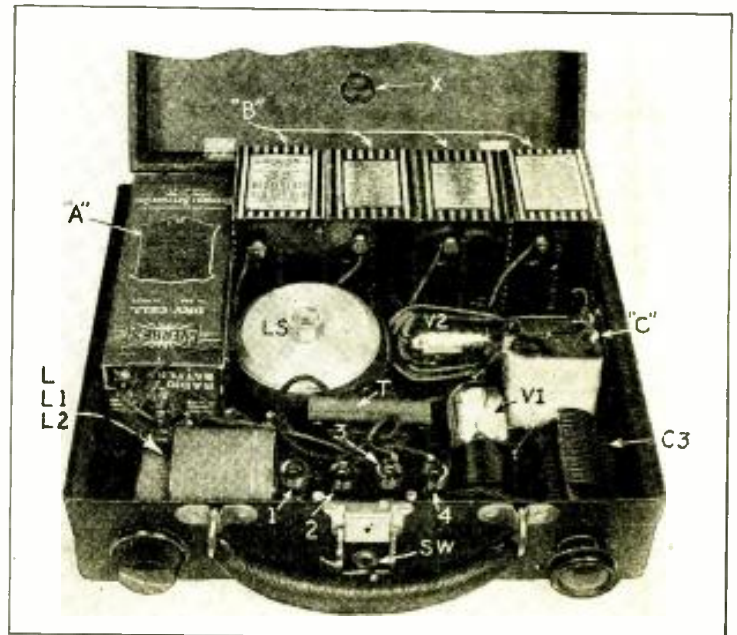

**Fig. 2 (above)**

The placement of parts may be compared with the photograph; the clips hold the speaker unit L.S. when the case is to be closed.

**Fig. C (right)**

The original receiver in its carrying case; for operation, LS is inserted in the hole X. Additional space will permit the constructor to apply rated voltages to the pentode, with better results. The value of the grid leak R is important in obtaining sensitivity; and the tickler L2 must be connected with proper polarity.





# The Short-Wave Superregenode

A NEW superregenerative circuit, with screen-grid detection and pentode output—sensitive and powerful

By CLIFFORD E. DENTON

RECENT ISSUES of RADIO-CRAFT have contained interesting details of new devices and circuits that enable the technician to obtain the last bit of efficiency from them. Not the least of these is the Pentode power tube with its possibilities for exceptionally high audio-frequency amplification.

And speaking of things to become *la mode*, the author harks back to the time when E. H. Armstrong told of a new receiver the like of which had never before been seen, with a response far greater than could be obtained from even his famous regenerative circuit. The main idea in a radio man's life then was: "What's the circuit? How does it work?" The conniving and detective work to obtain the inside "dope" and be first to build it—oh, boy!

Superregeneration has been with us for nine years, but little of what has been done toward refining the circuit has so far reached print. Experimenters have from time to time brought forth receivers based on the standard circuit as originally designed; but short-wave sets using this principle of operation have not reached the

Fig. A  
The 14-110-meter Superregenode with its plug-in coils. The lid lifts.

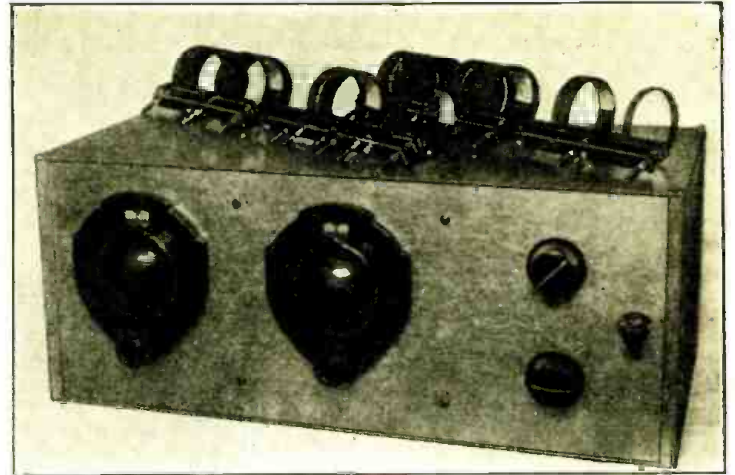

pinnacle of performance which a theoretical consideration of the exceptional efficiency of this circuit, at the very shortest wavelengths, would seem to indicate is readily obtainable.

The Superregenode, however, incorporates the very latest advances in tube and circuit

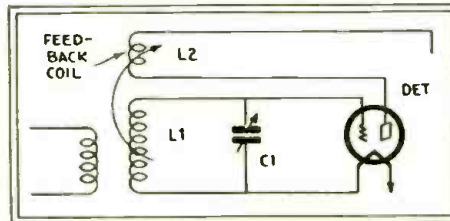

Fig. 1  
The regenerative detector is extremely sensitive, but oscillation limits its effectiveness.

design for effective operation at wavelengths between 14 and 110 meters, including as it does screen-grid and pentode tubes in a

superregenerative connection; and tube-for-tube, it far outstrips in performance any other radio set ever before offered to the short-wave fraternity. It opens up an entirely new playground for the short-wave enthusiast.

## The Hows and Whys

A simple explanation of the principle underlying the operation of a superregenerative receiver will be of interest alike to the old-timer "gone rusty," and to the novice.

The circuit shown in Fig. 1 is the familiar "3-circuit regenerative," wherein R.F. energy in the plate circuit is fed back to the grid circuit, through the inductive coupling between coils L1 and L2. By increasing this, additional energy may be fed into the grid circuit to augment by regeneration the strength of the incoming signal. Turning the regeneration control beyond the point of maximum regeneration will result in circuit oscillation; the tube then "plops over," and the signal disappears. In this condition, the circuit is useful for "C.W." or continuous-wave code reception; but it is quite unsuited for phone or broadcast reception. The most desirable adjustment point, for sensitivity, is just a hair's breadth below oscillation.

In the simplest terms, it may be said that the principle of the superregenerative circuit is to carry the regenerative action of the detector tube quite up to the point of oscillation; but to hold it under control by the periodical application of a *suppressor* voltage which checks the tendency to oscillate as soon as it sets in. This voltage may be applied in either the grid or the plate circuit or, in a four-element tube, to the screen-grid circuit, as shown here. (Fig. 2.)

The uniformity of this *periodical* application is obtained by the action of a local oscillator, the frequency of which determines the length of time during which a tube can approach the condition of oscillation without its being checked. For instance, if the local oscillator has a frequency of 10,000 cycles, every 1/10,000 of a second it will apply to the detector tube a negative voltage which damps the oscillation of the latter; and then remove this potential, applying a positive voltage which increases sensitivity.

Thus the action of the local oscillator enables us to push the detector further into that state of sensitivity in which oscillation takes place in a normal regenerative

## THE SUPERREGENODE RECEIVER

### Puts Short-Wave Radio on the Map, and Solves Many of its Reception Difficulties

WITH this story by the well-known radio engineer, Mr. Clifford E. Denton, we present to the radio world the most perfected short-wave receiver ever developed!

We challenge any radio constructor to equal its effectiveness, with any previously-known circuit, tube-for-tube.

On its "shake down" test in New York City, before a group of hard-boiled short-wave experimenters "from Missouri," distant short-wave 'phone stations were heard at loud-speaker volume throughout the largest room, there being sufficient power output from the battery-model SUPERREGENODE to drive a standard dynamic reproducer.

Its ramifications are legion: high-power portable loop sets; automatic-volume-control short-wave sets; short-wave adapters; Police radio sets; television receivers; interference locators; super-quality designs incorporating direct-coupled audio amplifiers with single and push-pull pentode output; combination transmitter-receivers; quasi-optical frequency receivers; prospecting equipment, etc.

The astounding efficiency, which goes up as the wavelength goes down, of this ultra-new factor in short-wave reception, the "Superregen(-ative Pent-)ode," is due to the use of a superregenerative circuit and three new 2-volt tubes—the general-purpose '30, screen-grid '32, and pentode '33—in the battery model; or the standard '27, screen-grid '24, and pentode '47, in the high-power or A.C. model.

The battery model is conveniently powered from any available current supply; and is as compact as good efficiency will permit.

Watch for the construction details of the "Big Bertha"—the high-power 3-tube A.C. model Superregenode, complete with power pack, which will appear in the next article.



detector. It is apparent that more signal energy thus reaches the plate circuit, and more will be fed back to the grid, before the tube can spill over. The result is tremendous gain in volume; and the effectiveness of this circuit increases greatly as the frequency of the incoming signal increases—that is, as the wavelength shortens.

Addressing the Institute of Radio Engineers, in June, 1922, Major Armstrong pointed out that the superregenerative principle is that "if a periodic variation be introduced in the relation between the negative and the positive resistances of a cir-

a pentode power audio amplifier V3, which handles the audio output of the detector. (Hence the name, "Superregen[eration and pent-]ode.")

In Fig. 2 it will be noted, the tuning circuit is of the "tuned-grid tuned-plate" type; and, as the inductances L1, L2 are in separate shield cans, the only existing place for feed-back is through the extremely low internal capacity of the screen-grid tube. At resonance, however, this tube will spill over into oscillation, if the screen-grid potential is correctly adjusted. Because both the grid and plate circuits are tuned, selectivity

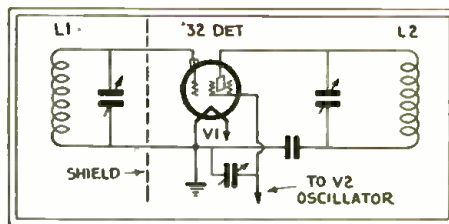

Fig. 2  
Varying the screen-grid voltage prevents oscillation from feedback through the tube.

In consideration of the pleasure that may be derived from experiments in unbeaten paths, two variations in oscillator design are shown in Figs. 4 and 5; the latter, as worked out by the writer, includes Patent "honeycomb" coils.

In Fig. 4 is shown an unusual arrangement for obtaining low-frequency oscillations, without the detriment of excessive bulk. A push-pull A.F. transformer and a 30-henry choke coil are used to generate the desired frequency; without condenser C1, the circuit will oscillate at its natural frequency, approximately 6,000 cycles. The output of the oscillator is fed to the screen-grid tube through one half of the secondary. Resistor R1 functions as a means of throwing the modulated tube circuit into and out of oscillation; and R2 controls the power output of the local oscillator.

The circuit shown in Fig. 5 is conventional; it includes a 50,000-ohm grid leak and a .00025-mf. grid condenser. Tuning condenser C1 has the large capacity of .001-mf. An optional method of tuning is to place the variable condenser as shown in dotted lines.

Any one of these oscillator circuits is sure-fire and, by substituting different values of capacity, the frequency of oscillation may be raised or lowered; the latter effect resulting when the capacity is increased.

Some explanation is necessary, of the extremely novel, effective and compact oscillator inductance design which has been selected as the best—that illustrated in the photographs.

An old Acme 30-ke. superheterodyne I.F. transformer (appropriately enough) had its outer protective metal covering removed; and over the outside of the exposed wind-

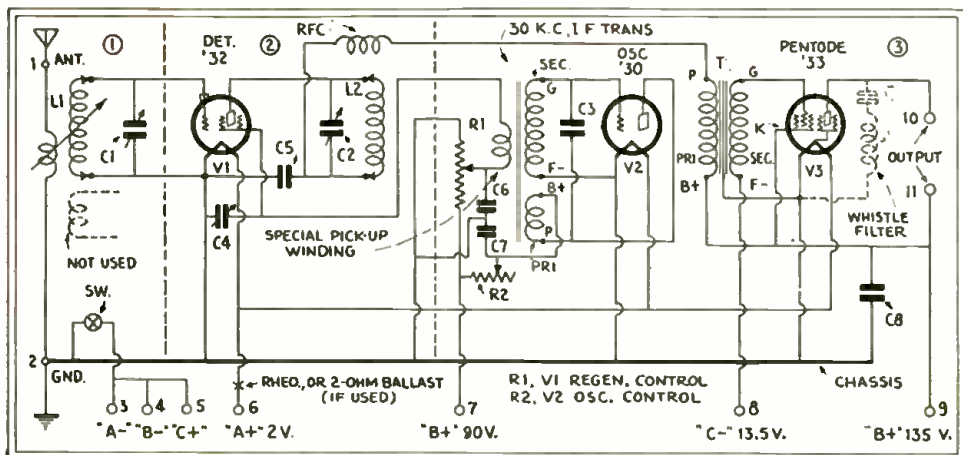

Fig. 3

The Superregenerative circuit for battery operation; see Fig. 11 for the detail of the "whistle filter."  
A push-pull output transformer for '45s is a good match for the '33 pentode.

cuit containing inductance and capacity, in such manner that the negative resistance is alternately greater and less than the positive resistance, but the average value of resistance is positive, then the circuit will not of itself produce oscillation; but, during those intervals when the negative resistance is greater than the positive, it will produce great amplification of an impressed E.M.F."

**The Superregenerative Circuit**

The latest laboratory development of this circuit is shown here for the first time in Fig. 3. It comprises a screen-grid detector or mixing tube V1; a suppressor-frequency "general-purpose" tube V2 which is coupled to V1 and working at a frequency which results in the desired blocking action; and

is exceptionally good; and every care must be taken to lay out, wire, and shield the receiver properly to keep circuit oscillation under control. Smooth action in this portion of the circuit was obtained through the use of a "Supertontrol" variable resistor for R1, which controls the energy fed into the detector.

**Optimum Suppressor Frequency**

Tests of frequencies between 4,000 and 30,000 cycles show that the maximum gain is obtained in the Superregenerative when the oscillator develops a suppressor-frequency between 4,000 and 8,000 cycles. Extremely interesting results were obtained with a fixed oscillator working at a frequency of 6,000 cycles.

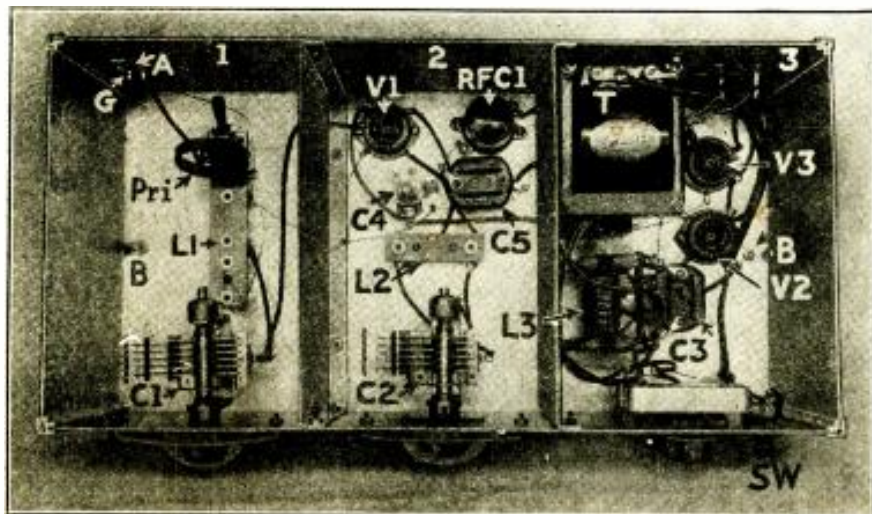

Fig. B

Bolts B hold the heavy aluminum case rigidly. The primary of L1 is hinged to the coil receptacles. L3, 30-ke. transformer; L, its 150-turn added winding.

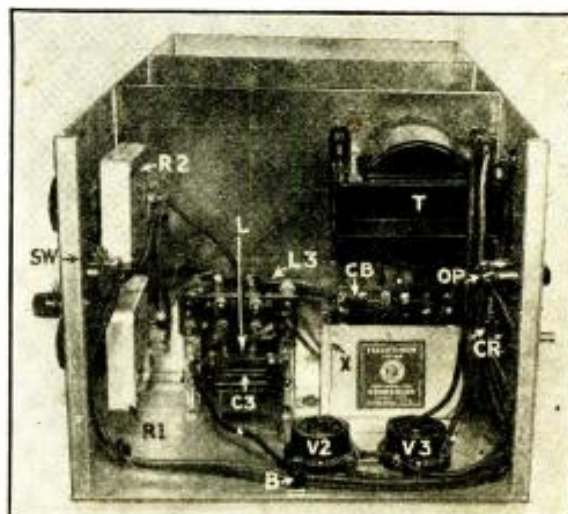

Fig. C

OP, output terminals 10-11; CR, battery-cable receptacle; CB, condenser bank; X, bare-wire "A-" common lead.



ing (the original primary-secondary combination) was wound a third or tertiary pick-up coil L<sub>3</sub> of 150 turns of No. 28 enameled wire, random-wound. Condenser C<sub>3</sub>, .001-mf., tunes the oscillator circuit.

This happy artifice worked right off the bat, and oscillated to beat the band; functioning exactly right for the particular receiver shown in the photographs.

**Construction and Wiring**

The first part of the construction job is to drill the holes in the aluminum box as indicated in the drawings; which give the dimensions of the set illustrated.

If the constructor wishes to be certain that the parts will mount correctly the first time, he must use the components specified.

If substitution is made, it will change the drilling specifications.

Having drilled all the holes, the next step is to mount the antenna and ground binding posts on the rear panel (Fig. 6); making certain that the antenna post does not short to the panel. The male member of the 7-wire cable and the speaker's dual terminal are mounted at the opposite end. This completes the assembly.

Next let us mount the instruments that appear on the front panel (Fig. 7.) At the right-hand side is placed the filament switch, and next to it the two 50,000-ohm "Tonatrols" R<sub>1</sub> and R<sub>2</sub>, which are insulated by washers. The plate circuit's tuning condenser C<sub>2</sub> also must be insulated. There are numerous ways in which this may be accomplished, and it is a little problem for the ingenuity of the constructor. The grid tuning condenser C<sub>1</sub> is the last item to mount on the aluminum panel.

On the base (Fig. 8) are to be fastened the coil mountings.

Wire in the antenna and ground connections, control-grid lead, and the leads of the tuning condenser. Place in position the first of two compartment interstage shields

(Fig. 9) and lock it tightly. (In short-wave receivers, loose shielding is the source of great noise.)

In the second compartment, place the four-prong socket for the type '32 tube; the 80-mmf. equalizing condenser C<sub>4</sub>; and the 250-millihenry choke coil RFC<sub>1</sub>. The .001-mf. fixed condenser C<sub>5</sub> is grounded to the chassis.

However, do not depend upon the chassis for connections, but run a wire to every point shown as grounded. This eliminates what would otherwise be a source of inter-unit connection, causing undesired effects.

Wire up all of the parts which so far have been assembled, and drill four small holes at the bottom of the second partition. One is for the plate lead to the A.F. transformer, one is an oscillator pick-up connection; another for the "A+" line; and the fourth for the "A-" lead and ground, a wire which should be bare. Pull these wires through the holes provided for them, after tightly bolting the second partition (also Fig. 9) in place.

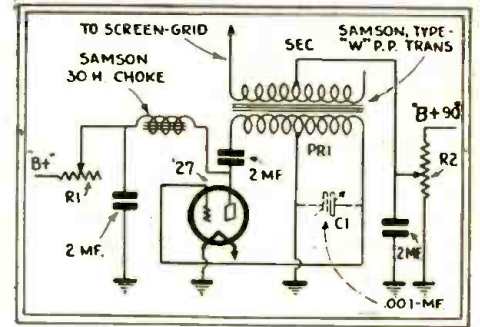

Fig. 4

One of the oscillators used experimentally to generate the suppressor-frequency.

Solder flexible leads to the filter block and fasten it in place. In this bank there are five one-microfarad condenser sections; one section bypasses the "B+135" lead; two more in parallel, the 50,000-ohm resistor R<sub>1</sub>; and the two remaining, also in parallel, at the moving arm of R<sub>2</sub> bypass the plate supply of V<sub>2</sub>.

The sockets of V<sub>2</sub> and V<sub>3</sub> and the 30-ke. transformer L<sub>3</sub>, with its added winding, are mounted in position and wired.

To prevent the resistor R<sub>1</sub> from shorting the plate supply when the receiver is not in use, and thus slowly draining the "B" batteries, "B-" and "C+" are connected to separate leads, which return to the chassis only through the filament switch.

Now fit the end shields (Fig. 10) into place.

**Operation of the Receiver**

Insert in their respective receptacles the requisite two coils for a given tuning range and turn the receiver's control switch to the "on" position. If the receiver is working, a thin high-pitched whistle will be heard in the background.

If this whistle is not evident, it is an indication that the oscillator is not functioning; and the first step is to reverse the leads to either the primary or secondary winding of the 30-ke. transformer (or the honeycomb coils, if used). This should correct the condition.

Vary the resistor R<sub>2</sub>; when volume of the whistle should change. Rotate the tuning control until a signal is heard; and, for 'phone reception, vary the voltage on the screen-grid of V<sub>1</sub> until the circuit is just under the point of pop-over. For C.W. signals, let it pop. Simple?

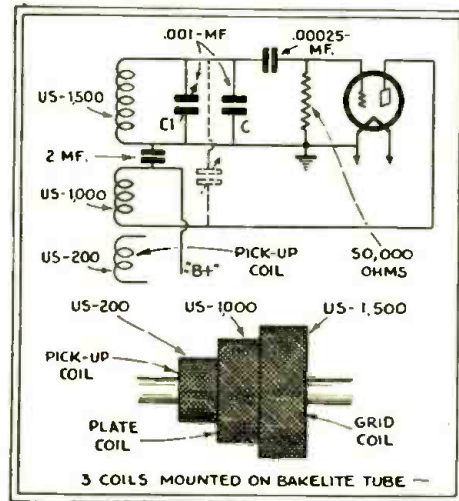
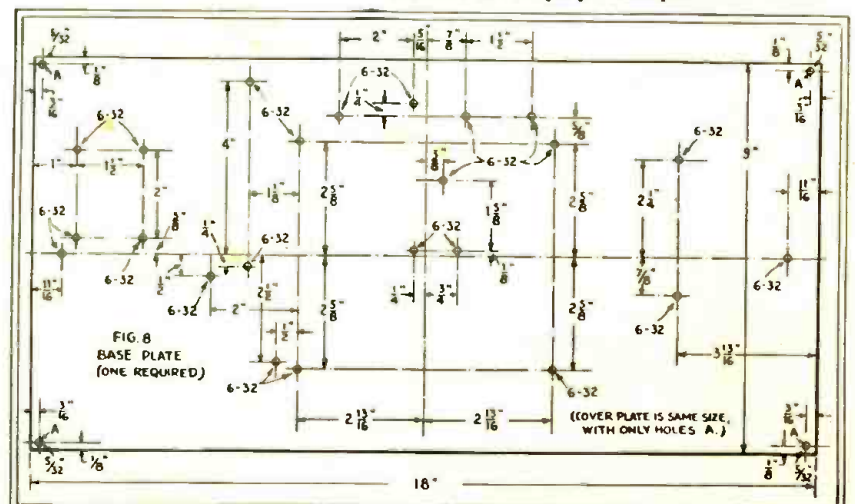
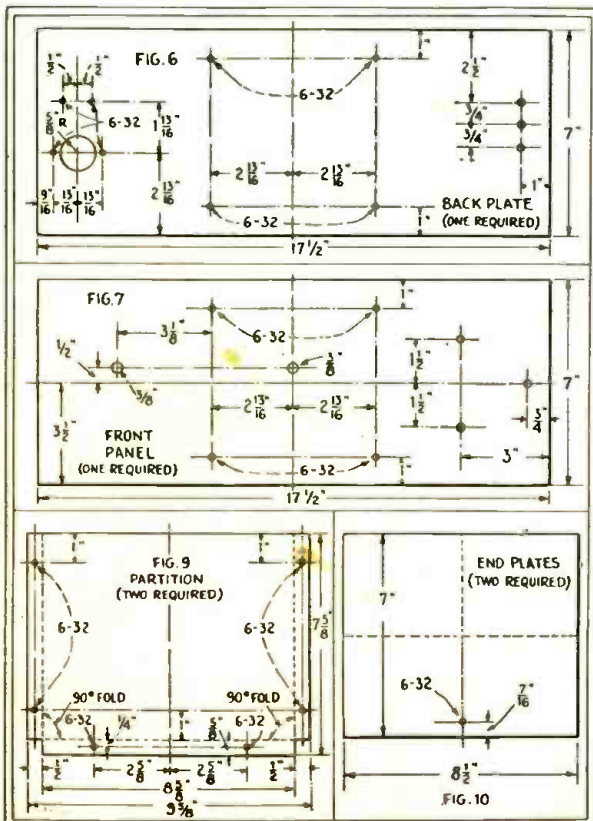

Fig. 5 (above)

A less compact oscillator design, using duo-lateral ("honeycomb") coils. This was tried experimentally, but is difficult to shield.

In Figs. 6 to 10, at left and below, the drilling measurements of the shields are indicated, for the receiver illustrated. They must be altered if necessary to suit the components selected by the constructor.



# Short-Wave Converters and Their Operation

*Some hints on improving reception with these popular accessories*

By RONALD LEWIS

Every short-wave receiver must be nursed along until the operator becomes conversant with its eccentricities; although it must be said that the Superregenerative handles very well; since once the setting for maximum volume has been determined the set may be tuned from one end of the range to the other, in either the oscillating (C.W.) or non-oscillating ('phone) condition.

When searching for 'phone signals tune by the chirps and then lower the screen voltage by means of the potentiometer R1.

The action of the battery and A.C. models is the same in tuning, but the R.F. gain and power output of the A.C. job is far greater. It is interesting to note that the voltage gain in the audio-frequency end of the battery-type Superregenerative receiver has a figure of about 34; while that of the A.C. model is about 49.

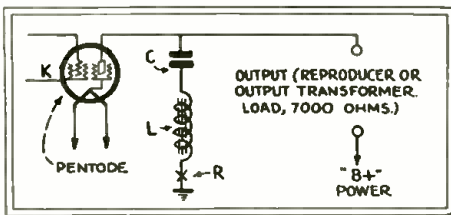

Fig. 11

The "whistle filter," or trap for the audible suppressor frequency. Values are suggested in the text, for 6000-cycle suppressor frequency.

For maximum efficiency, the load impedance in the plate circuit of the pentode in either case should be between 7000 and 8000 ohms at 60 cycles. Where headphones or a dynamic reproducer are used, a matching transformer of suitable design must be employed.

### Trapping the Suppressor-Frequency

If, for reasons not evident in the receiver constructed by the writer, the high-pitched whistle is considered objectionable, it may be expedient to have recourse to the circuit arrangement shown in Fig. 11; the tone filter shown in this diagram consists of a coil and condenser in series, connected across the output; that is between pentode plate and ground. If the oscillator's output frequency is known, the values required for L and C may be determined in a minute from the following formula:

$$L \times C = 259,300 \div f^2$$

Here L is in henries, C in microfarads, and f is in cycles.

For example, if the oscillator frequency is 6,000 cycles, a result is obtained as follows:

$$LC = \frac{259,300}{6,000 \times 6,000} = \frac{259,300}{36,000,000} = .00721$$

Since .0072 is the product of the value of the inductance and capacity, if we are using a 30-henry audio choke, we divide this L x C product by 30, as follows:

$$\frac{.0072}{30} = .00024\text{-mf.}$$

The nearest commercial condenser value is .00025—quite close enough for our purpose; for it will tune the circuit very close to 6,000 cycles and, acting as an acceptor-trap, it by-passes to ground the 6,000-cycle suppressor frequency that has served its usefulness in the receiver. If it is desired to

(Continued on page 115)

THE converter, adapter, and receiver all are the same thing to folk just breaking into the short-wave "game." Although our story is to deal specifically with the "converter," we will first define the other types of short-wave equipment.

Short-wave receiving apparatus, today, falls into three major classifications:

(a) The short-wave receiver, a complete, specialized unit designed particularly for the greatest efficiency at high frequencies (short wavelengths).

(b) The all-wave receiver—often a superheterodyne—designed for reception at broadcast wavelengths, whether long or short. In later models, it has been possible to obtain a good degree of efficiency over all operating ranges.

(c) The adapter, or converter, an accessory which, on being attached to a standard long-wave broadcast receiver, makes a combination capable of reproducing also short-wave programs, telephony, etc. The adapter has, generally, a circuit utilizing only the audio channel and reproducer of the receiver to which it is attached; the converter, properly, is a frequency changer, and uses also

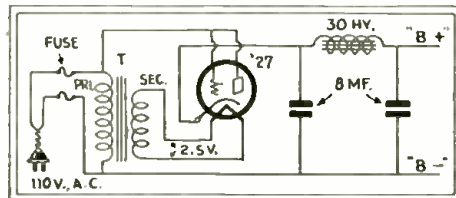

Fig. 2

A simple current-supply unit, adequate for the plate voltage of a short-wave converter.

the R.F. and (if there be any) the intermediate amplifiers of the longer-wave set.

The different types of short-wave receivers may be classified, as to circuits, just as are the regular broadcast receivers. The same statement may be made also of the short-wave adapter; the adapter feeds a detected signal into a broadcast receiver at the detector input or output; and, usually, derives its power from the broadcast receiver to which it connects.

A short-wave converter, ordinarily, is self-powered; it connects to the input posts (antenna and ground terminals) of a broadcast receiver. Converter units are so named because they "convert" a short-wave program into a "broadcast-wave" program; utilizing, to obtain this action, the superheterodyne principle of operation. The converter may be constructed either with or without a signal-frequency-tuned input circuit.

All of these types of short-wave receivers, all-wave receivers, adapters, and converters, with their subdivisions, have been illustrated, diagrammed, and described in

past issues of RADIO-CRAFT. However, as a starting point, we will refer more specifically to the short-wave "super-converter," a frequency changer without a signal-frequency-tuned input circuit, described in the June, 1931 issue of RADIO-CRAFT, (page 734).

It will be recalled that a short-wave converter consists, essentially, of a tuned local oscillator, and a modulator or first-detector. The oscillator heterodynes with different incoming short-wave signals, resulting in a constant beat-note or "difference-frequency" for any setting of the oscillator, or of both oscillator and tuning control, as the case may be. That is to say, by mixing the two (signal and oscillator) frequencies in a modulator or first-detector tube, an intermediate frequency is created. The converter's output post is connected to the antenna post of a standard broadcast receiver, which is tuned to this difference- or intermediate frequency—which may lie between the extremes of 190 and 600 meters, depending upon the design of the converter unit, as previously explained.

Some converters incorporate a stage of R.F. or signal-frequency amplification, tuned or untuned, ahead of the oscillator and first-detector. The merit of this design has been discussed in past issues of RADIO-CRAFT.

### Superheterodyne as I.F. Amplifier

A word here about the use of a converter with a superheterodyne receiver, before continuing with our technical fault-finding. It may be of interest to remark that a broadcast set using the superheterodyne circuit, when connected to a converter using the superheterodyne circuit, produces a novel hook-up which may be analyzed as follows, using a simplification of the circuit as an instance: one stage of signal-

(Continued on page 114)

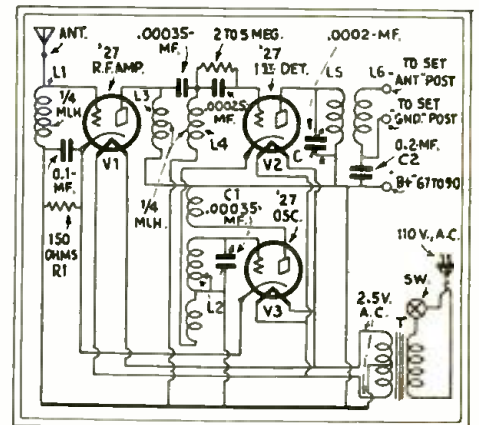

Fig. 1

A method of reducing interference, with an untuned-input converter, is a tuned R.F. output transformer, C-L5-L6.



# Stenode's Selectivity is Revolutionary

*How station and other radio interference is overcome by the application of a novel, though simple, method of intermediate-frequency tuning and compensation*

**N**O radio invention of the past few years has occasioned such general interest and discussion, in the engineering world, as the Stenode system of transmission and reception; of which a general explanation was given some months ago in the pages of RADIO-CRAFT.\* However, it is now assuming, not only technical but commercial interest in the United States, as the result of systematic work in which the engineers of the Stenode Corporation have been quietly engaged during the past year.

As the original article explained, the Stenode principle, invented by a British scientist, Dr. James Robinson, was conceived in an endeavor to make more efficient use of the wavebands allotted for transmission purposes. For that purpose, Dr. Robinson designed a transmitter which is to make use of an extremely "narrow channel" (in Greek, *stenos odos*, from which the name); and thereby make it possible to operate without interference twenty, or perhaps a hundred, stations where one was hard-pressed for room before. However, such a transmitter requires a special receiver; for it cannot be received intelligently on one of ordinary type.

The first interpretation of his idea, therefore, by the radio profession was that a complete revolution in radio, and simultaneous scrapping of all existing material, would be demanded. However, the very interesting development has been brought out, that not only is the Stenode receiver suitable for the reception of any existing broadcast stations, but it has an actual superiority for that purpose, by reason of its extraordinary selectivity. For that reason, the Stenode receiver has assumed an immediate importance, without waiting for the development of the special transmitter.

At the recent radio trade show in Chicago, in fact, the Stenode demonstration receivers were subjects of principal interest; as a considerable number of manufacturers, both of receivers and of components, have

**T**HE significance of the Stenode principle, in the development of both broadcasting and television, promises to be very considerable. Its general extension means great enlargement of transmitting facilities, less interference, bigger and better television images.

While these things, so far as transmitting technique is concerned, are some distance in the future, the Stenode receiver is now an accomplished fact, having reached the stage when it is ready for the application of production methods.

Stenode receivers, built up of standard parts, with the exception of the crystal-control tube, have been demonstrated to representatives of RADIO-CRAFT. Their selectivity, in the presence of a high-power local (WABC) is great; the local could be tuned in and out in a twinkling, seeming to occupy but a portion of its channel on the dial. The marked feature, however, in comparison with standard receivers, is the apparent great reduction of noise, permitting a distant station to come through on the Stenode while, on the other sets, it is lost in its background.

While constructional data and circuit constants are not available for this article, it will be but a short time before manufacturers are ready to release the necessary material for constructors and, later, superheterodynes of different Stenode models for the set trade.

been investigating the commercial possibilities, and several of them have arranged for licenses under the basic patents. For the set constructor, first of all, and very soon the radio dealer and Service Man, some further explanation of the Stenode is therefore of practical value.

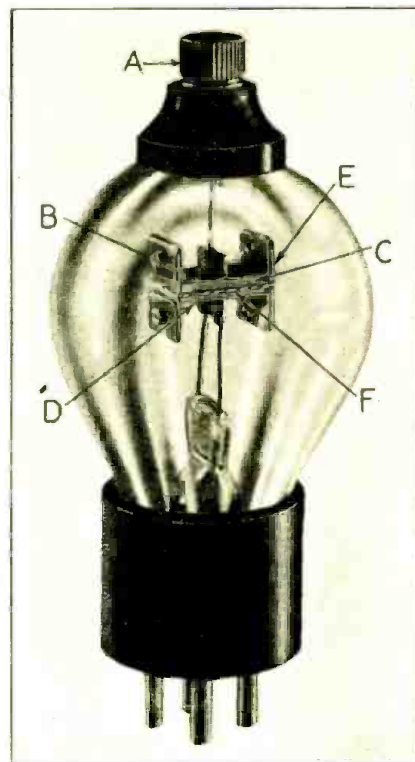

**Fig. A**  
The 175-ke. crystal is C, supported by the cord F between electrodes B-D. E is an insulating holder, and A the upper lead.

### The Limits of Selectivity

First of all, in every technical discussion, comes the question: sidebands or no sidebands? This has been debated by the best mathematicians in the profession, and the formulas which have flown back and forth are entirely too complicated for general exposition. Suffice it to say, however, that calculations may be made on the basis of almost any conception of the radio wave—as a carrier of constant frequency but varying amplitude—as a carrier of constant amplitude but varying frequency—as a carrier accompanied by sidebands—or an un-

*(Continued on page 106)*

**Fig. 1 (right)**

The dark area C, indicating the selectivity of a crystal-controlled Stenode, is compared with a very sharp-tuning superheterodyne of normal circuit (B) and a band-selector-tuned R.F. set (A). The area between curves indicates interference eliminated by the Stenode.

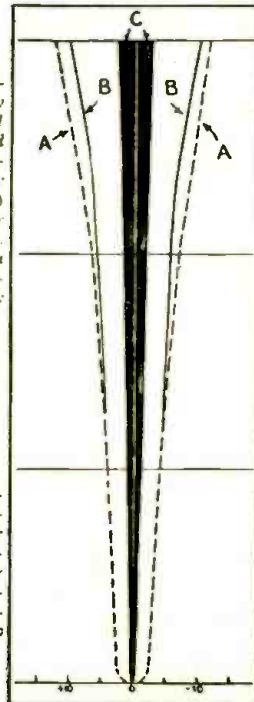

**Fig. 2 (left)**

The Stenode intermediate amplifier; varying C regulates the sharpness of the tuning. The compensator is a very low-impedance coupling, reducing the low notes to proper proportions.

\* See "The Stenode Radiostat System," by Clyde J. Fitch, in RADIO-CRAFT for October, 1930.

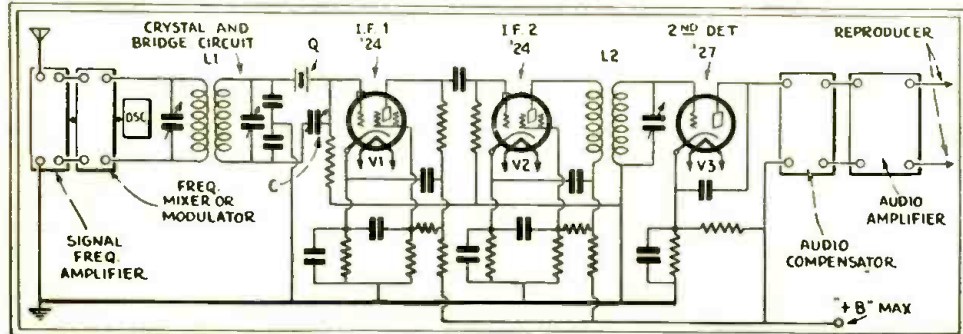

# Replacement of Volume Control

*The many systems found in commercial radio sets are here boiled down to essentials, and the typical values used are given*

By H. G. CISIN, M. E.

**F**AULTY volume controls are the cause of more complaints from set owners than any other part of the radio; replacing volume controls is the Service Man's daily task. When we realize that the usual volume control is of somewhat delicate electrical construction, and that it receives considerable mechanical wear, we can readily appreciate the necessity of giving it considerable attention. Aside from becoming actually worn out, many volume controls become corroded and cause terrific noise in the speaker when slightly moved. Such defects have been eliminated in the new types of variable resistors, as described in recent issues of *RADIO-CRAFT*. Many varieties are available, so that replacements may be made, or new methods of control effected, with consequent improvement in set operation.

In many of the older receivers, volume controls were placed in any convenient location, with little or no regard to the effect they might have on tone quality and selectivity. Now, the volume control has received the attention it deserves and careful circuit arrangements have been perfected. Thus, the Service Man has a wide variety of methods from which to choose, and the most satisfactory one for any particular set can be easily selected.

### Control with Quality

In the modern radio receiver, whether with or without power detection, there is a certain maximum of R. F. energy that can be applied to the detector before serious distortion results. For this reason, the volume control should regulate the R. F. energy before it reaches the detector. In some of the older sets, the volume control was placed in the audio amplifier. While it served the purpose of controlling volume, it did not reduce the enormous amount of R. F. energy applied to the detector when receiving powerful local stations; and, consequently, distortion resulted.

In other instances, while the volume control was placed in the R. F. amplifier, it had a tendency to broaden the tuning; and this effect would always occur near the most powerful stations, which were normally received over too broad a band. Now, the practice is to place the volume control in the R. F. circuits in such a manner that

selectivity is not sacrificed. The illustrations show a number of such circuits that are recommended and employed by radio manufacturers. (Left- [or right-] hand direction of control is conveniently obtained in potentiometer-type (3-lead) resistors connected as rheostat-type (2-lead) units, by connecting to the opposite end—where taper is not used.—Tech. Ed.)

Since the ear is logarithmic in its action with respect to sound intensity, or volume, it is customary to employ "tapered" resistors for the volume-control unit. This gives uniform control of volume as far as the ear is concerned. Tapered resistors are recommended in all of the following circuits.

Of the various methods of volume control about to be described, it will often be found, while servicing a set, that one radically different from the one originally employed may serve the purpose better; or the Service

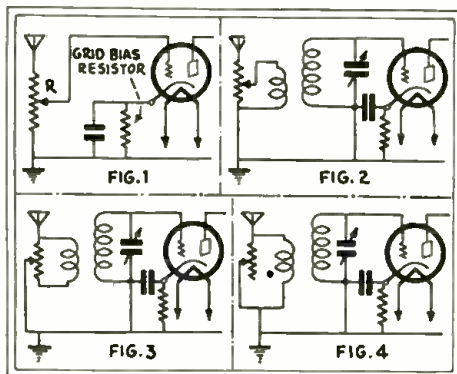

Four types of antenna volume control.

Man may have in stock a particular unit, of a resistance range suited to only one type of circuit, but which will serve the purpose just as well.

### Control at the Input

The simplest of controls is perhaps that of Fig. 1; the control unit serves as an antenna coupling resistance, as well as a volume control. In this circuit, the maximum value of the resistance is not critical, but it should be tapered. The Clarostat graphite unit (P5-1A) having a resistance of 1,000 ohms; or a 6,000-ohm wire wound Clarostat is suitable (some sets use up to 25,000 ohms or more.—Tech. Ed.), though any equivalent unit may be used.

Fig. 2 shows another method of controlling the antenna input; in this case, a different type of unit should be used. One with a tapered element of 10,000 ohms resistance (such as the P5-10A) is recommended.

The circuit of Fig. 3 is very similar to that of Fig. 2; but it has the advantage that the movable contact arm is connected to ground, and body capacity is thereby eliminated. In some cases this arrangement gives better control of strong signals and makes it possible to cut the volume to a minimum, even on super-sensitive receivers. The same unit employed for Fig. 2 may be used.

Another simple circuit is that shown in Fig. 4; in this the signal is merely shorted to ground, and the arrangement has the same advantage as that of Fig. 3, so far as hand capacity is concerned. The resistance value is not critical, but it must be fairly high; say in the neighborhood of 100,000 ohms (such as the R5-100A). The compression type Clarostat, of which millions are in use, is often used in this circuit. It gives smooth control, the knob making several revolutions for its complete range. (Other compression units of similar range may be used.—Tech. Ed.)

Any one of these four methods may be recommended where a change in volume control is necessary or contemplated; all very simple, fool-proof, and easily installed. They do not affect the tuning or selectivity of the set, and there is no danger of introducing hum or feed-back.

### Combination Antenna and Grid Controls

A combination control, using a single potentiometer (Fig. 5) is desirable on screen-grid or other sensitive sets where control of more than one circuit is essential, to preserve tone quality, and to reduce loud signals to a minimum when desired. In this case one potentiometer controls two circuits; the "C" bias of one or more tubes, and the antenna circuit. It is so arranged that the "C" bias is increased as the signal is shunted to ground; so that both the sensitivity of the tube and the signal intensity are reduced simultaneously. A 10,000-ohm (P5-10B) unit, may be used; although a "wire wound" Clarostat is preferable, in view of the amount of current flowing through it, and

*(Continued on page 108)*

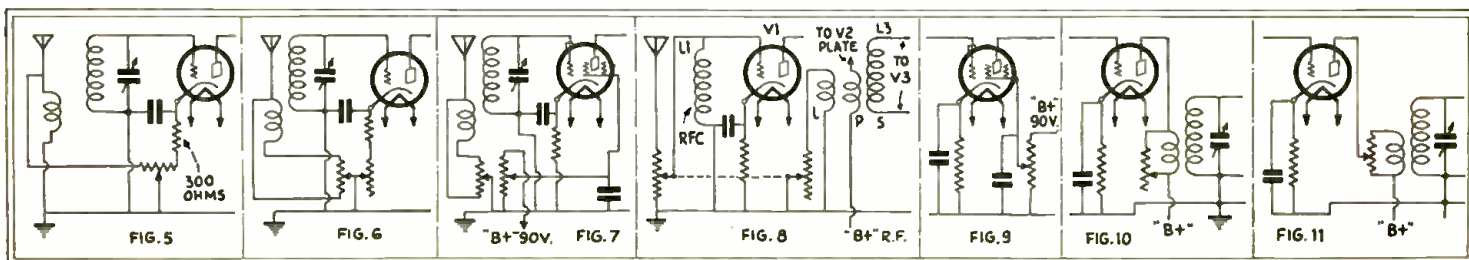

Practically all methods of controlling volume in the R.F. amplifier use either a potentiometer (3-terminal) or rheostat (2-terminal) to vary tube voltages; this may be combined with an input control in the antenna coupler. The choice of circuits by the designers has depended on cost, patent restrictions, circuit convenience and individual preferences.



# An Ideal Sound System for High Power

*The design of a high-quality, tone-compensated audio amplifier for general purposes, and of a 50-watt unit which will step up its output to the volume required for a large sound system.*

By C. H. W. NASON

THE average radio technician has but a slight acquaintance with the circuits and apparatus involved in high-powered A.F. amplifier systems, nor is he expected to be entirely familiar with the developments in the field of sound. It is the purpose of this article to describe a "sound system" capable of ideal performance in all branches of this field and lying within the constructional capabilities of the average technician. Before going further into the description of this channel, the writer wishes to express his thanks to the engineering staffs of both the American Transformer Company and the De Forest Radio Company for information given so freely and for assistance in the peculiar problems arising in the design of the 50-watt output amplifier.

It is a known fact that the ideal response-characteristic of a sound system is flat over the entire channel, extending from the primary source to the auditor's ears. Because of various factors, it is admittedly impossible to achieve a flat response over the required range in certain links of the system. Notable examples of this are due to the fact that phonographic recordings are deficient in the lower register, or to the fact that architectural defects in the home or in the auditorium destroy the faithfulness of the ultimate rendition. It is therefore desirable that the frequency response of the amplifiers shall be within the control of the operator.

During the past year Mr. J. C. Aceves (formerly research assistant to Dr. M. I. Pupin) has developed a system whereby this end may be readily achieved. The Aceves

tone-compensated amplifier expresses recognition of the fact that an amplifying system may be called into service for various purposes calling for widely differing tone correction.

In the reproduction of phonographic recordings, for example, it would be desirable to place a decided emphasis on the low frequencies and to provide compensation in the high-frequency response, dependent upon the level of the "scratch" which lies almost entirely in the higher frequencies. On the other hand, the reproduction of music received by radio or from a microphone pickup would require no loss in the higher register to avoid "record scratch," nor would the emphasis of the lows be requisite to enjoyable reproduction. In recording, it is at times advisable to cut off slightly the response at the lower end, where the mechanical power of strong bass passages might damage the recording equipment or cause the recording stylus to make an excursion into the next groove, thus breaking down the side-wall.

### A Tone-Compensating System

The two-stage amplifier shown schematically at the left of Fig. 1, is capable of variation over a wide range, as to frequency response. A careful examination of the circuit will show that, except for certain unusual resistors, condensers and chokes, the system is not different basically from the average two-stage amplifier employing push-pull amplification in the output. To be sure the input to the push-pull stage V2-V3 is slightly unorthodox; the signal for V3 being obtained through an auto-transformer connection of a center-tapped im-

pedance, L4.

The input to the amplifier may be taken from a 5000-ohm circuit; the transformer required having a 5000-ohm secondary and a primary suited to the equipment with which the channel is to be associated. The secondary voltage is applied across a potentiometer R1 which serves as a volume control. The circuit comprising C1 and L3 is resonated at about fifty cycles, to provide an emphasis of the bass; the degree of which is determined by the resistance R3 connected across the inductance. It will be noted that the transformer T1 is fed through a relatively small condenser C2; in other words, but little energy is supplied to the

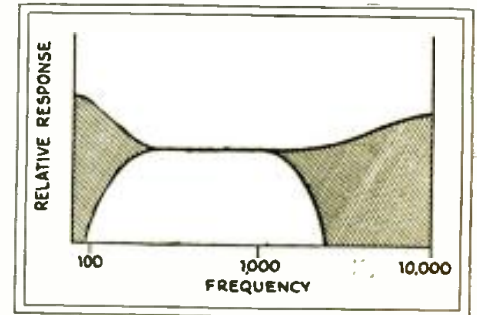

Fig. 2

The shaded area represents the gain control over frequencies in the amplifier below; it controls them independently at each end of the gamut.

transformer primary except at the high-frequency end where the reactance of C2 is small. With the resistance R2 all in circuit, there will be obtained a considerable emphasis of the higher frequencies, due to the fact that the high frequencies traversing the condenser C2 will be added to those present across the choke L3, in the other section of the input circuit.

The '27 tube V1 is parallel-fed through the resistance R7 and has in its plate circuit a "tone corrector" (R4, C5) which may be employed in cutting the highs, should this be necessary to overcome record noise or scratch. This device is similar to the "tone controls" now used on radio receivers.

A second circuit (C6, L4, R5) resonated at about fifty cycles is included in the input circuit feeding the push-pull stage. The series resonance is additive to the effect obtained in the first circuit which emphasized

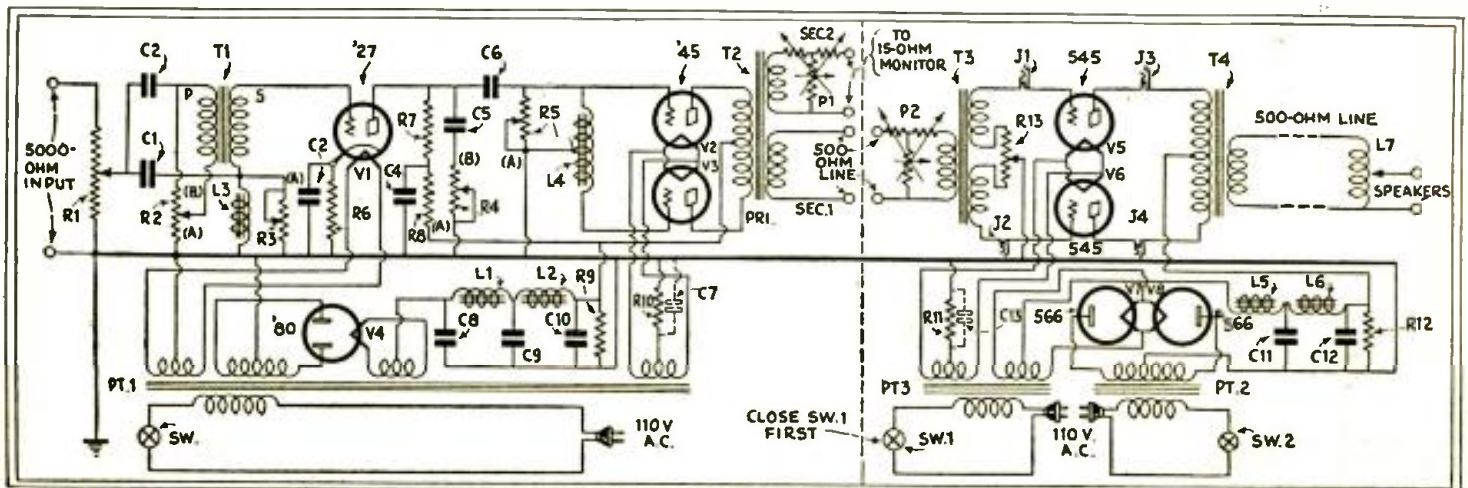

Fig. 1

At the left, the design of a push-pull amplifier of standard output, sufficient for a small room, and adapted to radio, phonograph, or microphone input. It may be regulated to give faithful overall response, correcting any lack of fidelity in either the input device or the reproducer. At the right of the dotted line is shown a 50-watt push-pull amplifier, which may be added to give an output suitable for a hotel or a public address system of large proportions. Constants for both units are given in the text.

the lows, and its effect is controllable through variation of the resistance, R5.

**Adjustment of the Characteristic**

(a) To obtain maximum low-frequency gain, set R3 and R5 for maximum resistance across the circuit (arms at A).

(b) To obtain minimum low-frequency response, short out resistor R3 and partially close R5.

(c) To obtain maximum amplification of the high-frequency tones, set R2 so that the maximum resistance is across the transformer primary (arm at A) and set R4 with maximum resistance in series with C5 (arm at A).

(d) To cut off the higher frequencies, short-circuit the transformer primary by means of R2 (arm at B) and close R4 so that no resistance is in the circuit (arm at B); thus placing C5 directly across the plate circuit of the first tube, V1.

The frequency-response of the system is variable over the range indicated by the shaded portion of the curve in Fig. 2. The response-characteristic curve may be adjusted to pass through any point within the shaded area—either for correction of actual deficiencies or for the purpose of securing individually pleasing effects.

The amplifier as shown, with the output transformer T2 to feed both a dynamic reproducer and a 500-ohm line, may be used as a phonograph amplifier for home or auditorium use; the two '45 tubes being capable of sufficient output to feed one or two dynamic reproducers. For home use, it would probably be best to utilize an output transformer designed to feed a single reproducer.

**A 50-Watt Amplifier**

Where it is desired to feed a number of dynamic reproducers, it is often necessary to obtain more power than is possible from the tubes usually available to the technician.

The DeForest "545" Audion is capable, singly, of an undistorted output of 20 watts. Two of these tubes in push-pull will provide an output slightly lower than fifty watts, which will tax the capabilities of ten to twelve man-sized reproducers. (Caution: full volume from two "545's" in push-pull will cause serious damage to one or two reproducers unless the volume is held well in hand.) The circuit at the right of Fig. 1 presents nothing unfamiliar to the average technician in the first instance. There are, however, several cautionary measures to be taken.

The "566" rectifier tubes V7, V8 are of the "hot-cathode, mercury-vapor" type and it is essential, to avoid their destruction, that the filaments be heated for at least a minute before plate voltage is applied. The resistance of the path from plate to filament during operation is but a few ohms, and the heat losses are quite small. If, however, the plate voltage is turned on *before* the mercury-vapor path is completely formed the tube will be seriously damaged. It is for this purpose that the two switches Sw1, Sw2, are provided.

It will be noticed that the input to the filter circuit is through a choke L5 with no input condenser. Choke input to the filter permits the use of a more inexpensive trans-

(Continued on page 119)

# Pentodes and Their Use

*With values for a D. C. Pentode Receiver and Amplifiers, both Single and Push-Pull*

By C. E. DENTON

**T**HE student of modern radio may well pause and reflect on the step-by-step progress in the field of electronics. The efforts of manufacturers, to design and make commercially available new types of tubes that offer electrical and economic advantages, are to be lauded.

There is a saying in the trade, "First the tube, then the set"; for engineers and designers of radio receivers and sound systems look to the tube designers for the new devices with which to create the modern radio receiver; and the equipment for

combines large power outputs with an exceptionally high voltage gain.

**A 110-Volt D.C. Pentode Set**

The power output and voltage gain of the pentode are so great that care must be employed in the design of the circuits for use with these tubes. The effect of the large plate (signal) current flowing through the biasing resistor should be minimized as much as possible by proper bypassing; as shown in Fig. 1, which is a design for a 110-volt D. C. electric receiver, using a new type of a pentode tube for use at low plate voltages. The capacity of the dry electrolytic bypass condenser C5 is 25 microfarads! The other constants of the various components are given below:

- One shielded antenna coil, L1;
- Two shielded R.F. coils, L2, L3;
- Two R.F. chokes, RFC1, RFC2;
- One A.F. choke (A.F. trans. sec.), CH1;
- One 30-henry filter choke, CH2;
- Two 800-ohm resistors, R2, R3;
- One 50,000-ohm volume control, R1;
- One 10,000-ohm biasing resistor, R4;
- Two 0.5-meg. resistors, R5, R6;
- One 1,200-ohm biasing resistor, R7;
- One 7,000-ohm resistor, R8;
- One 5,000-ohm resistor, R9;
- One 3-gang, .00035-mf. variable condenser, C1, C2, C3;
- Seven .01-mf. by-pass condensers, C4, C5, C6, C7, C8, C9, C13;
- Two 1-mf. by-pass condensers, C10, C11;
- One .001-mf. by-pass condenser, C12;
- One low-voltage dry-electrolytic condenser, 25-mf., C14;
- Two 200-volt filter condensers (one 2-mf.; one 4-mf.), C15, C16;
- Four UY tube sockets;
- One vernier dial;
- Four binding posts;
- Two line fuses, F;
- One off-on line switch, Sw.

(Continued on page 112)

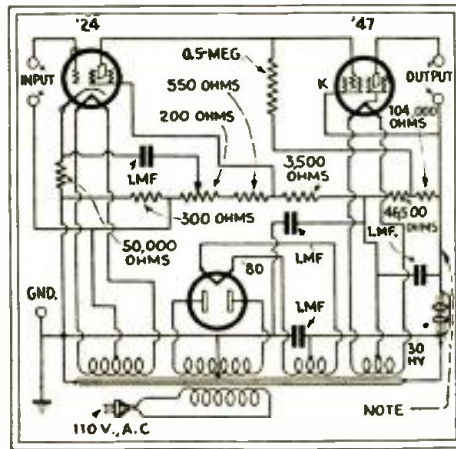

Fig. 2

Note that the plate lead must be clear of other apparatus and wires. The filter must supply 41 milliamps at 435 volts.

its companion fields, such as sound pictures and television. After this step has been taken, there must follow improvement of its associated units.

The output stage of every radio receiver or audio amplifier, until recently, employed a three-element (triode) tube and was designed to deliver large power outputs. Power had to be obtained at a sacrifice of voltage gain. The new pentode, on the contrary,

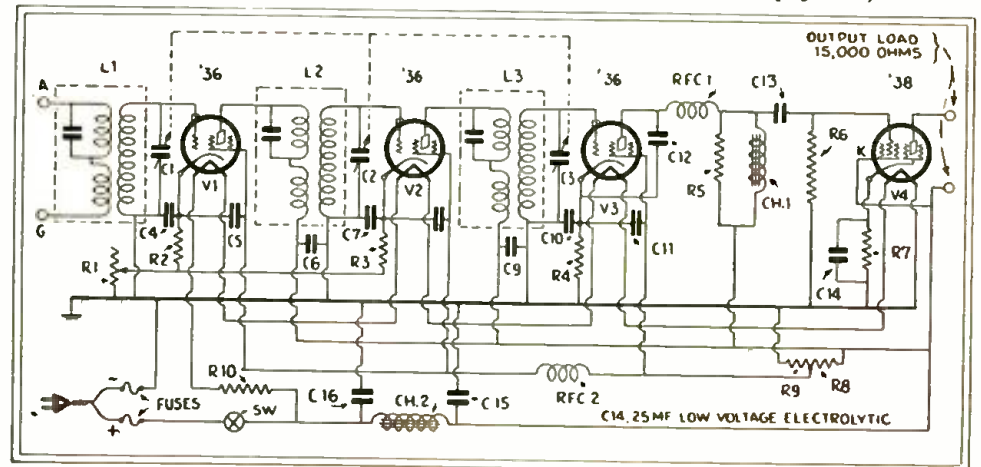

Fig. 1

A receiver designed for operation from a D. C. light line; the R. F. coils are of the type described by Mr. Denton in his article on page 33, of last month's issue. The ballast resistor R10 must pass 0.3-ampere and drop it to the 25 volts required for the four tubes in series; fortunately, this value is not critical. It is 283 ohms, for a 110-volt line, and 317 ohms at 120 volts.



# Modernizing Old Radiolas With Two-Volt Tubes

(Directions for altering the "Super-VIII," "25," "AR-812," and other superheterodynes)

By F. L. SPRAYBERRY

**I**N the May issue of RADIO-CRAFT, the writer told how to operate the Radio "28" with the new 2-volt tubes. Since then, he has been deluged with requests for the data needed to operate other older Radiola superheterodynes with the new 2-volt tubes. (Every letter, by the way, has been answered by Mr. Sprayberry.—*Tech. Ed.*) So he started experimenting to find out how difficult this would be.

As before with the "28," simple insertion of the new tubes, without making any changes in receiver wiring, was first tried; however, this did not prove satisfactory. The final solution is set forth here; and it is suggested that these instructions be followed, specifically, for quick work. Directions for using the very latest thing in power tubes, the new 2-volt "pentode" ('33-type) are given below!

Directions for removing the catacomb (hereinafter called "cat.") unit from the container will not be given here. Those who have not read the article in the May, 1931, issue of RADIO-CRAFT should do so now, for hints on removing the cat from its container. Much of the information given in the former article applies to this series of receivers.

The "Super VIII" or "AR-810" the "24," the "25," the "26," and the "AR-812" receivers employ the same type of circuit; there being some differences in their internal wiring, and quite a difference in external appearance and wiring. The circuit is, however, essentially the same and, with wiring changes, all models can be made exactly alike.

### Addition of Modern Features

The things we are going to accomplish in this change-over are: the use of six 2-volt "general purpose" type-30 tubes, or five type-'30 tubes and one type-'33 "pentode" power tube; the addition of a tone control; the conversion of the second detector to the "power" plate-characteristic type; and provision for an "antenna coupler," so that the loop may be dispensed with, if desired. It is recommended, however, that an antenna

and ground be used at all times (in localities not in close proximity to powerful transmitters) for best results.

Fig. 1 shows in schematic form the complete circuit of the "25" after all changes to modernize it have been made. The "AR-812" series differs slightly in that the grid return for the sixth tube is made, not externally, but to the same common point as the other tubes; and that UV sockets are provided in the set, instead of UX. For detailed descriptions of all models involved, see pages 495 and 627 of the April and June, 1930, issues of RADIO-CRAFT.

At the rear of the cat unit will be found small insulated wires (hereinafter called "whiskers") which connect to large soldering lugs. Those wires coming from the cat will be referred to as "inside" connections; and those running from soldering lugs to other parts of the receiver, as "outside" connections. All numbers are given in the order of the terminals as they appear when you face the rear of the receiver, and are counted from left to right.

The "25" has 17 "inside" connections and 20 "outside": the "AR-812" series has 14 "inside" and 16 "outside" connections.

No difficulty should be experienced in removing the receiver chassis from the different cabinets, if one exercises care.

### The Old "25" Chassis

Consider first the "25". Unsolder all the cat whiskers from the soldering lugs and lift the cat free from the chassis. Be sure to leave the whiskers in their respective holes since, otherwise, difficulty might be experienced in identifying them later.

Next, place the cat in a pan of hot water (as explained in the preceding article) until it can be lifted from the container. Let the wax harden again; after which you are ready to make the internal wiring changes.

First, short-circuit the grid leak and the grid condenser of the second detector (the grid leak is red and of the carbon, pig-tail

type). Connect a short piece of wire to the thin copper strip leading down from the grid hole of the fourth socket; with the unit turned upside down and whiskers farthest from you, the grid terminal is the sixth on the strip, from the right (or seventh from the left). Connect the other end of this short wire to the other side of the grid leak; thus shorting the grid leak and condenser. This permits us to apply a negative grid bias to this tube, after providing a grid-return connection.

Next turn the unit around (still upside down) with whiskers toward you. Notice that, between the third and fourth sockets, the filament terminals are connected together by a thin metal strip and to this strip is connected a wire and another strip; the

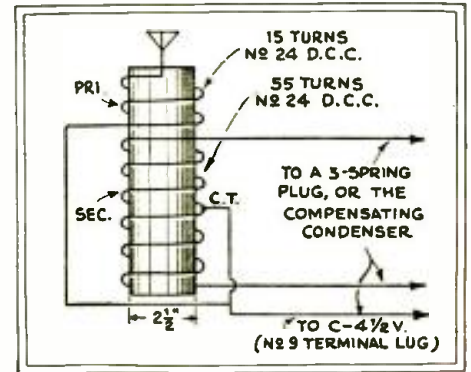

Fig. 2

The specifications shown above are those of a coupler used with the Radiola "28" to replace the loop. For other models, instructions are given in the text.

latter is the "grid return lead" for the second detector. Cut this strip and connect an eight-inch insulated wire to the end going down into the wax. (Disregard the other end of the strip you have cut, but be sure it does not short to other parts of the circuit.) Now turn the unit over, and bore in the panel a hole large enough to pass the eight-inch lead; this completes the internal wiring for the second-detector circuit.

Now turn the unit around, and locate the grid strip of the fifth socket. Bore a hole through the top and close to the strip; connecting to it a 12-inch lead. The loose end of this lead is then to be soldered to the tone-control resistor R2, an 0-50,000 ohm variable unit which is to be mounted on the wooden panel. The other side of this resistor is connected to the "outside" terminal No. 2, which will be "C-4 1/2."

Tube No. 2 is both the oscillator and the first detector. The original plate potential used for this circuit was 90 volts; however, this must be reduced to 45 volts, in the following manner.

Turn the unit so that the whiskers are away from you. There are three long machine-screws, the heads of which can be seen from the top of panel; all three of these screws are connected together. Remove the connection between the two at the left; this isolates the plate-supply lead of tube No. 2 from tubes Nos. 1, 3 and 5. Now connect an eight-inch wire to the head of the left machine-screw; the latter wire now will be the "B+" connection for tube No. 2; run it to "B+45."

The next thing is to separate the grid-return lead of tube No. 2 from the grid returns of tubes Nos. 1, 3 and 5; this may

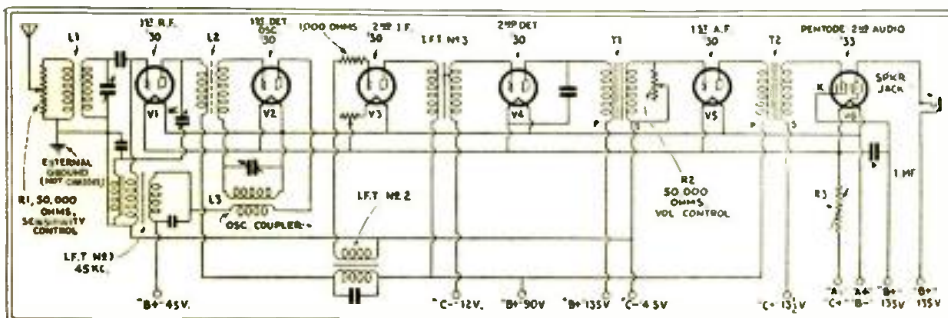

Fig. 1

Here we have a modern battery-operated two-volt superheterodyne with pentode output; compact, economical and efficient. The components necessary are an old Radiola "25" or "812", which can be had for a song, two variable resistors, and perhaps seven tube adapters. The diagram gives the result after the change; "before taking" is shown in previous issues of RADIO-CRAFT.

be done at the top surface of the panel. Place the unit right side up, with the whiskers towards you; and tilt it forward until a row of machine-screws underneath can be seen. Notice that wires are soldered to the heads of these machine-screws, from the top side of the panel. Screws 3, 6 and 9 should be connected together, and the lead from these brought out through hole No. 2. Now solder a wire to the head of screw No. 4 and bring it out through hole No. 5.

Unsolder, where it connects to the grid return of tubes Nos. 1, 3 and 5, the wire that now leads from the grid return of the second detector. Bore a hole between holes 3 and 4 for the wire from "B+oscillator—First detector." Bore another between holes 13 and 14, for the tone-control wire. Remove "inside" connection No. 17. Hole No. 17 is to take the suppressor-grid lead of a '33 pentode, if one is used; if not, this hole serves for the tone-control lead.

**Reconnecting the Cat**

You are now ready to replace the cat in its shield container; it is then to be remounted on the supporting springs. Start connecting the "inside" and "outside" circuits; wiring as originally, with the following exceptions:

Remove the wire from "outside" No. 7, which is connected to the rotor of the loop condenser; "outside" No. 7 is to become "C—" 12 volts for the second detector. Remove the oscillator-coil lead from No. 2 "outside," and re-connect it to "outside" No. 12; this connects the grid return of tube No. 2 to "A+." After all "inside" to "outside" connections have been made the battery cable is to be connected to the screws which you will find at the top of the soldering lugs.

Counting from left to right: No. 12 is "A+B—;" No. 10, "A—C+"; No. 2, "C—4½"; No. 6, "C—22½" ("C—13½," if a pentode is used, instead of a '31 power tube); No. 7, "C—12;" No. 20 may be used as "B+45," for tube No. 2; No. 14 as "B+90"; No. 13 is "B+135" for the power second detector; No. 17, "B+135" for the output power tube; and No. 19, 135 volts for the suppressor grid of the pentode, if a '33 tube is used in socket No. 6.

To use a '33 pentode power tube, the Service Man will require a small UY (five-prong) socket mounted on one-inch studs over socket No. 6; for this purpose, bore small holes through the panel near the holes of No. 6 socket, and connect the plate, grid and filament prongs of this socket respectively to the plate, grid and filament terminals of the UY socket you have mounted. Connect the cathode or "K" terminal of the UY socket to "outside" terminal No. 19; and put a 1-mf. bypass condenser between the "K" terminal of the UY socket and any convenient "A—" lead. The circuit will operate with greatly increased volume, using this tube. Be sure to connect 135 volts to "outside" terminal No. 19, which is then the suppressor-grid connection.

It will be necessary to obtain a "Na-Ald" adapter, "No. 934," for tube No. 3, and a 1,000-ohm resistor (which comes with it) to prevent oscillation of the second I.F. tube circuit. Or, if you desire, the 1,000-ohm resistor may be connected in series with the grid circuit, as described for the "28".

(Continued on page 120)

# Short-Wave Inductances and How to Figure Them

*With a few tables which the experimenter may find it convenient to have on hand.*

"HOW many turns on the coil" was answered, as regards the long-wave broadcast band, in an article by Clifford E. Denton in the July issue of RADIO-CRAFT (page 37). Tables were given, as well as general rules which may be applied to the short-wave bands; but some further explanation may be added.

Recapitulating the previous discussion, the wavelength of a tuned circuit is directly proportional to the square root of the product of the inductance and the capacity in that circuit; resistance in the circuit affects only the sharpness of tuning.

combination can cover this; we must change inductances, and, if we stick to one condenser, select one with capacity rather too high for the short waves, and too low for the long waves. The solution has been, in the latest short-wave models, to introduce coil- and capacity-changing switches, and other complicated mechanical devices.

There are reasons for endeavoring to keep the inductance as high as possible, and to use the lowest practicable capacities; the signal strength developed across a circuit is proportional to the inductance, when other things are equal. The variometer method of changing inductance is theoretically attractive, but difficult in practice. For that reason, the simplest and most generally followed method of changing wavebands is to plug in a suitable set of coils for each band.

**Calculating Inductance**

As said before, the upper tuning range of any coil is determined by the total capacity across it. Table I gives the inductance-capacity products for selected wavelengths from the broadcast band down to ultra-

(Continued on page 109)

**TABLE I**

Kc.	Meters	*LxC	Kc.	Meters	*LxC
1500	199.9	11260	6750	44.4	555
1600	187.4	9900	7000	42.8	520
1700	176.4	8770	7250	41.4	480
1800	166.6	7815	7500	40.0	450
1900	157.8	7020	7750	38.7	420
2000	149.9	6340	8000	37.5	395
2100	142.8	5750	8250	36.3	370
2200	136.3	5225	8500	35.3	350
2300	130.3	4775	8750	34.3	330
2400	125.0	4400	9000	33.3	315
2500	120.0	4060	9250	32.4	295
2600	115.3	3750	9500	31.6	280
2700	111.1	3500	9750	30.8	265
2800	107.1	3250	10000	30.0	255
2900	103.4	3010	11000	27.3	210
3000	100.0	2815	12000	25.0	175
3250	92.3	2400	13000	23.1	150
3500	85.7	2080	14000	21.4	130
3750	80.0	1800	15000	20.0	113
4000	75.0	1585	16000	18.7	99
4250	70.6	1405	17000	17.6	88
4500	66.7	1250	18000	16.7	78
4750	63.1	1120	19000	15.8	70
5000	60.0	1015	20000	15.0	63
5250	57.1	920	25000	12.0	41
5500	54.5	845	30000	10.0	28
5750	52.2	765	40000	7.5	16
6000	50.0	705	50000	6.0	10
6250	48.0	650	60000	5.0	7
6500	46.1	600	75000	4.0	4

\* L in microhenries; C in micromicrofarads.

For instance, the highest wavelength in the regular broadcast band (545.1 meters) is 2.73 times the shortest (199.1 meters); therefore, if the inductance in the circuit is constant, there must be 7.48 times as much capacity across the coil at the upper wavelength. That is to say, the difference in capacity between the upper and the lower settings of the tuning condenser must be just 6.48 times the miscellaneous capacities of the circuit (the minimum condenser capacity, the self-capacity of the coil, and the other capacities which exist between all leads, etc., of different R.F. potential). So, if there is 324 mmf. variation in the condenser, the rest of the circuit must have a residual capacity of 50 mmf., if the dial settings are to cover exactly the broadcast band and no more.

But, when we get into short waves, the difference in capacity and inductance must be very much greater than the difference in wavelength. A circuit tuned to 15 meters can have only 1/179th the combined capacity and inductance of one tuned to 200 meters. No ordinary condenser-and-coil

**TABLE III**

TWO-INCH CIRCULAR FORM: (Inductances in Micronerries)						
No. of Turns on Coil--	No. of Turns of Wire Per Inch					
	7	11	17	25	33	60
3	0.7	0.9				
4	1.1	1.3				
5	1.6	1.9	2.3			
6	2.0	2.6	3.1			
7	2.6	3.2	3.9	4.5		
10	4.3	6.6	6.9	8.1	8.9	
16		9.9	12.6	16.4	17.2	
20		14.7	19.4	23.7	26.7	32.0
25			26.2	32.9	37.9	45.9
30			34.0	43.5	49.6	60.6
40				63.6	76.6	94.1
50					102.3	131.6
60						152.0 171.4

ONE AND THREE-EIGHTHS INCH FORM (Tube Base)						
No. of Turns on Coil--	No. of Turns of Wire Per Inch					
	7	11	17	25	33	60
3	0.4	0.6	0.6			
5	0.9	1.1	1.3	1.6		
7	1.4	1.8	2.3	2.7	3.0	
10		3.1	3.9	4.7	5.3	
16			7.1	8.6	10.0	12.1
20				13.4	16.4	19.5
25					21.4	26.8
30					27.9	36.0
40						54.0
50						72.7

Inductance values of some short-wave coils.



# How to Work with Two-Volt Tubes

*An English experimenter, with several years' experience in construction with tubes of this type, gives American set builders a few tips, and the circuit of his 110-volt D.C. set*

By C. A. OLDROYD

**H**ANDS seem to have reached across the seas and made an exchange of some of the best things in radio today: America now uses the two volt low-consumption tubes, sisters of the family which England carefully developed in more than two years patient effort; and—at last—England sits up and takes serious notice of the superhet, truly America's own, both in conception and development.

While writing these notes, on the West Coast of England, within sight of the sea, I am listening to our latest superhet, working off a ten-inch loop; and I feel we have perfection at last. Moreover, this set works off two-volt "valves" only, and (thanks to a power pentode in the output stage) the volume on stations hundreds of miles away is all one can bear, even in a large room.

The writer was no believer in two-volt tubes when they first made their appearance here, about three years ago; he pinned his faith to five-volters, and for some time forgot all about the little fellows. About a year ago, he tried some of the new two-volters once more, and had the surprise of his life. Since then, he has used them in many sets, and has never been disappointed with their performance.

## Low-Resistance Connections

There are several points with two-volters which require attention; and not the least is to make sure that the filaments really receive their full rated voltage. With five-volt tubes, a slight resistance between contact pins and socket contacts does not seem to matter much; the tube will work practically as well on 4.75 volts as on 5. But the 2-volter must get its proper supply if it is to put its best foot forward.

Care must be taken to have clean contacts right through the filament circuit and, if a two-volt storage battery is used to feed

the filaments, make sure your connecting lugs on the battery cable are clean, and pay due attention to the insulated nuts of the battery. Even a trace of acid will corrode a brass surface in a few hours; the best preventative is a touch of vaseline on the stem below the contact surfaces. (Fig. 1.)

Again, the battery cable should be sound. Occasionally, one meets with a cable which on examination shows the majority of strands broken, merely held together by two or three frail strands. The ideal method of making connection between set and battery is the "pigtail;" as this cuts out any possibility of poor contacts between set

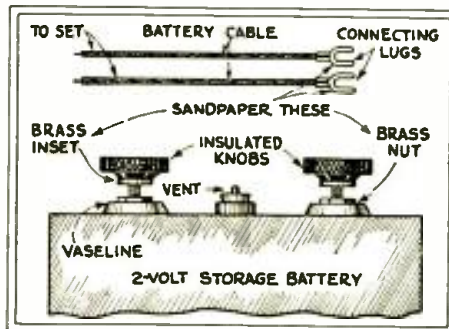

Fig. 1

Keep a clean metallic surface at each contact.

terminals and cable ends. (Fig. 2.) Incidentally, one set of connections is automatically eliminated, since the cable ends are soldered directly to the supply points.

Some constructors object to the pigtail because it is in the way when building a set; but we can get over this difficulty by coiling up the free end to a diameter of, say, two or three inches, and attaching this coil to the receiver's chassis. Then the pigtail will no longer whip about when the chassis is moved or turned (Fig. 3.)

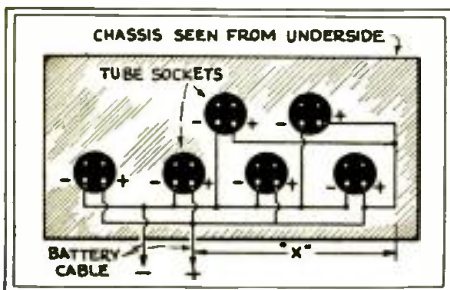

Fig. 5A

Here we have nice square leads, which carry the current for the filaments through common wiring and introduce unwanted coupling.

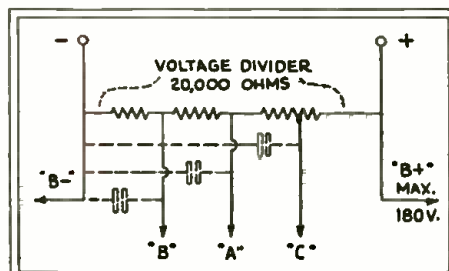

Fig. 5B

This power-supply unit is similar in principle to that at the left. It is well-known that bypassing is necessary to prevent back-coupling.

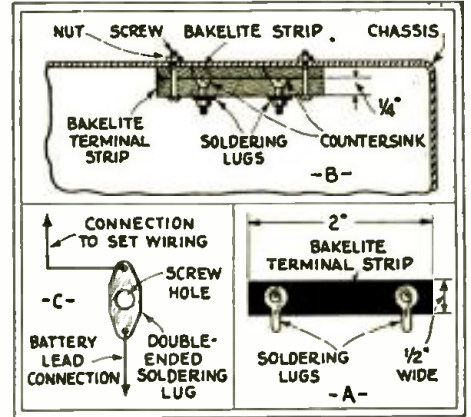

Fig. 6

A substantial method of making connections.

## Trouble At the Switch

But perhaps the greatest enemy to good results with two-volt filament tubes is the switch, if it is a bad one. With the multi-tube sets of today, the switch must pass quite a respectable amperage without voltage drop; and the writer, at least, has had more trouble with switches than from any other source. Finally, he made a study of them, and adopted as a rule that only those types must be used in which the contact points are readily accessible for cleaning.

Theoretically, all switches have accessible contact points; but in practice, a good deal of dismantling is often required to get at them. In a compact set, it is frequently very difficult. If a jack-type switch is used, like the Yaxley, for instance, the contacts are readily accessible and can be cleaned without disturbing the switch or wiring; a small file with very fine teeth, such as used for cleaning magneto contacts, serves the purpose; this file should be used only for this job, and kept clean. Another point of importance is to brush the contacts after using the file, to remove any fragments that might prevent the points from meeting squarely. (Fig. 4.)

Incidentally, the switch should be mounted in such a position that the contact points can be easily got at, say with the springs facing downwards.

## Filament Circuit Coupling

Occasionally, with receivers having two or three stages of R.F., a kind of back-coupling has been found with some low-consumption filament tubes; ultimately, this was traced to the filament circuit. This back-coupling showed itself in oscillation and instability, and the remedy proved extremely simple.

In a receiver fed by batteries, the plus and minus filament connections are usually

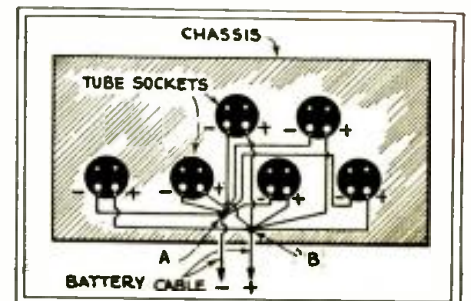

Fig. 5C

The filament wiring shown above may look less attractive; but each tube has its individual leads, and resistive coupling is eliminated.

picked up and soldered on as the builder goes along. After one stage is completed, he starts with the next: "Now, let's see,— we want a couple of filament connections, well, we'll hook them onto the last tube." And so the second tube filaments are coupled to the first, the third to the second, and so on. Finally, we have a scheme similar to that shown in Fig. 5A. The section "X" is common to several tubes, and feedback can occur via the filaments, despite careful shielding, etc. The writer's own theory is that we have here a case similar to back-coupling with high-resistance voltage dividers, as used in battery eliminators. Fig. 5B shows a typical arrangement: if the taps "A," "B" and "C" feed the R.F., detector, and first audio stages of a set,

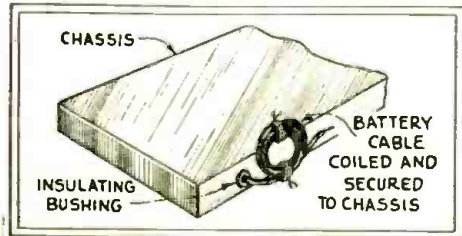

Fig. 3

Careful attachment of the battery cable to the chassis, when a plug is not used, will save trouble of various kinds later.

back-coupling is almost sure to occur; the remedy is to shunt a bypass condenser across each tap.

Yet this feedback can be cut out if we lower the resistance of the voltage divider; using one of 5000 ohms instead of 20,000, for instance. The resistance of the whole of the voltage divider, compared to that between taps, appears to be the deciding factor, as soon as a given threshold value of total resistance in the voltage divider is exceeded; and here we have the similarity to our "usual" filament circuit, as shown in Fig. 5A.

To "decouple" the filament system, the plan outlined in Fig. 5C should be adopted; each negative filament lead is taken directly to the common collector point "A"; similarly each plus lead to "B"; and the battery cable is soldered to "A" and "B". This precaution is well worth while, and means only a little more wire and trouble.

To provide anchorage points for the ends of the filament leads, and also for the battery cable, a strip of bakelite is fitted with two good-sized soldering lugs held in position by two small screws with countersink heads. (Fig. 6.) To prevent accidental contact with the chassis, a thin strip of bakelite is placed between the connector strip and the chassis, when mounting the former.

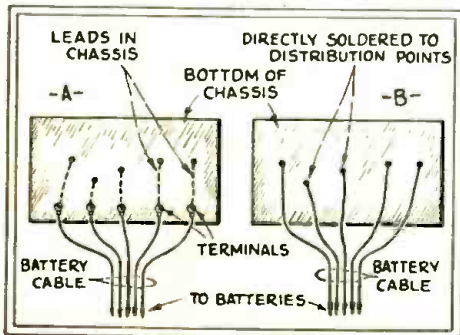

Fig. 2

Running each battery lead direct to its point in the set, as at B, simplifies wiring and reduces the number of joints.

The soldering lugs can be "double-ended," one side taking the filament leads, the other the end of the battery cable. Such lugs are easily cut from copper sheet (see detail at C, Fig. 6).

A D.C.-Line Amplifier

Despite the good showing 2-volters make when used as power tubes, some experimenters will wish for more "punch" in the output stage. The best solution, when house current is available, is a separate power amplifier. The writer is forced to use direct current from his light-line and (since there appears to be a fair amount of interest in D.C. work, judging from letters and articles in recent numbers of RADIO-CRAFT), the following account of a very successful push-pull amplifier may be of interest.

The original amplifier was built up from parts at hand, and the intending constructor can choose his own material, according to preference for one make or another.

To begin with, no filtering is used; and we therefore get the full line voltage on the plates of the amplifier tubes, for we have no voltage drop in chokes to contend with. The power tubes are five-volt, 1/4-ampere type, and directly heated; the circuit is given in Fig. 7.

Two 30-watt lamps are used as ballast resistances and, since each passes just under 0.26-amp. (with the resistance of the tube filament taken into account), they are ideal for our purpose. It will be noted that each tube has its own ballast lamp, rather than using one 60-watt lamp for both.

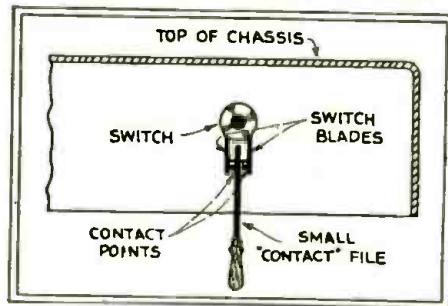

Fig. 4

A fine file, judiciously used, will give clean, low-resistance switch contacts and consequently much better reception.

The reason is that, if we use a 60-watt lamp, and place the filaments of both tubes in parallel, one tube filament may burn out. Then the other, remaining, filament will have to take the whole of the current, which amounts to 1/2-amp.; in other words, we can say good-bye to the survivor too! With separate ballast lamps, no harm will come to the tube if one is pulled out, for instance.

The circuit diagram does not depart from standard practice. The input transformer T is of high quality, having a ratio of 3.3:1. The secondary of that actually used did not happen to be center-tapped; so an electrical center was formed by two 100,000-ohm resistors, shunted across the whole of the secondary. To their central point "M" the "C—" lead is connected.

A center-tapped choke Ch replaces the usual output transformer; and complete isolation of the loud-speaker windings from "B" voltage is effected by two 2-mf. condensers in the leads from plates to speaker.

An amplifier of this type is ideal; it can

(Continued on page 122)

# RADIO

made easy to learn

# AT HOME



**R**ADIO is a fascinating profession. Now you can become an expert in any one of its twenty different branches. Simply by studying in your spare time at home or at any of the four resident schools operated by RCA Institutes, Inc.

It is not hard to study radio the way it's taught by RCA Institutes. You learn radio by actual experience on the latest type of radio equipment. And you need not give up the position you now hold. You can study an hour a day or any number of hours a day, at home in your spare time.

The RCA Institutes' Home Laboratory Training Course teaches you in a most thorough manner. You learn about servicing, operating, radio telephony and telegraphy... also instruction in sound motion picture installation, maintenance and repairs. And you receive at no additional cost the complete RCA Institutes' home laboratory equipment, a modern outlay of apparatus furnished to every student, enabling you to easily solve radio problems.

Send for our FREE BOOK Today!



**RCA INSTITUTES, Inc.**

RCA INSTITUTES, Inc.,  
Dept. NP-8  
75 Varick St., New York, N. Y.

Gentlemen: Please send me your FREE book which tells about your laboratory method of radio instruction at home.

Name.....  
Address.....  
Occupation.....



# Radio-Craft's Information Bureau

**SPECIAL NOTICE TO CORRESPONDENTS:** Ask as many questions as you like, but please observe these rules:

Furnish sufficient information, and draw a careful diagram when needed, to explain your meaning; use only one side of the paper. List each question.

Those questions which are found to represent the greatest general interest will be published here, to the extent that space permits. At least five weeks must elapse between the receipt of a question and the appearance of its answer here.

Replies, magazines, etc., cannot be sent C. O. D.

Inquiries can be answered by mail only when accompanied by 25 cents (stamps) for each separate question. Other inquiries should be marked "For Publication," to avoid misunderstanding.

## SONORA "MODEL E"—COLONIAL "MODEL 36"

(128) Mr. James A. Paulder, Scranton, Pa.

(Q1.) What is the probable cause of circuit oscillation and low sensitivity in a "Model E" Sonora receiver? The circuit of this set is very difficult to locate.

(A1.) Fig. Q128 is the schematic circuit of the "Model E" Sonora receiver, as produced for the 1929 trade. For this circuit, and the following information concerning it, we are indebted to Kessel and Rummel (Saginaw, W. S., Michigan), who handle parts and give service on Sonora sets.

The circuit is the conventional one used in conversion jobs on 1927 circuits; a neutralizing circuit of the modified Rice type is used.

It is probable that the circuit is in need of neutralizing and re-alignment. The neutralizing condensers are mounted on their respective R.F. sockets, while a detector alignment condenser is found on the first A.F. tube socket.

A trombone-shaped copper shield slides over the antenna coil, which is a 160-turn unit, shunted by a .00023-mf. condenser. It is essential that perfect 1-mf. condensers be used in the connection to each leg of the 1.5-volt filament. Note that the pilot light must be insulated from the chassis.

The power for this receiver is obtained from a special pack, either Majestic or Acme, shown in Fig. Q128A. A Jones 13-wire plug-in cable connects the two units. Because of the resistance of the neutralizing windings in the R.F. filament leads the pack is made to provide a 2.4-volt potential at its terminals; this voltage is lowered to 1.5 at the R.F. tube socket by the drop across these windings. Nichrome-wire leads take care of this drop in the '26-type A.F. stage.

(Q2) In the May, 1931 issue of RADIO-CRAFT, page 641, Mr. Freed referred to the Colonial "Model 36" midjet receiver. Is this circuit available?

(A2) The complete diagram of the Colonial "Model 36" screen-grid receiver is shown in Fig. Q128B. Note the manner in which push-pull operation is obtained from the screen-grid detector output; through the use of a center-tapped A.F. choke coil. The primary coils of the main tuning dial; while auxiliary adjustment of this coupling is used to obtain volume control. The kilocycle setting of the dial should correspond to the station frequency when the last cipher of the latter is omitted.

A hum-control resistor is situated at the left of

the light-line. The tone control is the extreme left knob on the front of the panel.

The following data are offered to Service Men by the manufacturers, for use when it becomes necessary to replace either the tuning condensers or the R.F. transformers:

The station selector dial should be set to the frequency of some strong local station, above 1,000 kc.

receiver will not tune to 1,500 kc. Service Men are cautioned against changing the settings of these condensers unless the tuning units have been replaced.

Of course, it is well to reduce the volume control's setting each time the signal is brought up with the compensating condenser; since any change in volume is more easily detected at a low signal level.

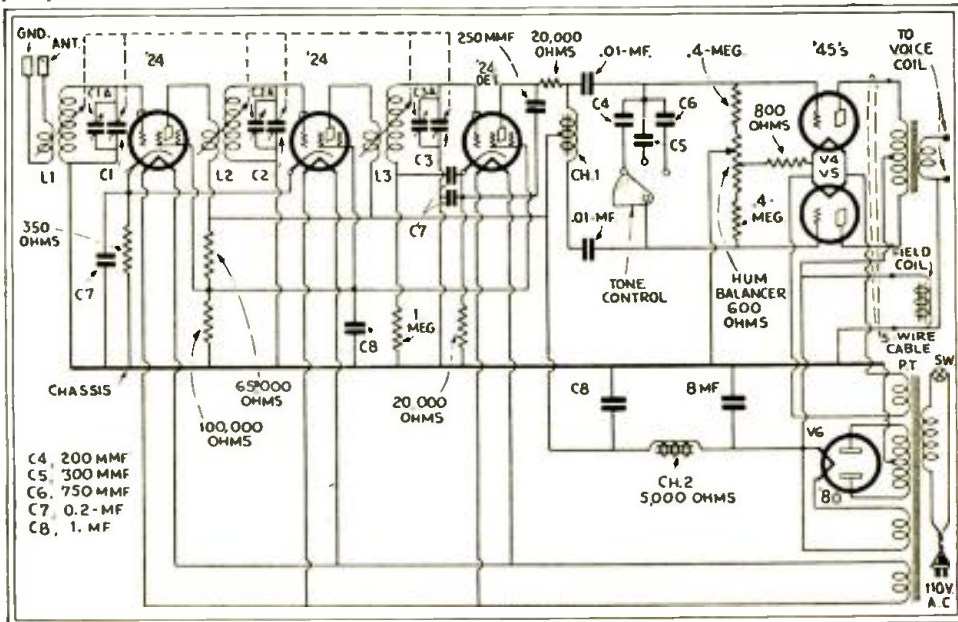

Fig. Q128B

Colonial "Model 36" midjet receiver; the antenna lead is green; and the ground, black. The center-tapped choke (Ch) is required for push-pull operation. Interchanging the '45's may help in adjusting hum balancer.

and preferably between 1,200 and 1,400 kc.; and the volume control then reduced until the signal is barely audible. The compensating condensers should be adjusted (preferably by means of the three screws reached through the three holes in the top of the tuning condenser's cover) until the signal is at a maximum. Care must be taken not to adjust the compensating condensers too tight; or the re-

## DAYRAD "SELF-BIASING" TUBE CHECKER—KINGSTON "B" ELIMINATOR

(129) Mr. Alton E. Fargo, Duluth, Minn.

(Q1) In the July, 1931 issue of RADIO-CRAFT, on page 43, you described the DayRad "Type L" Tube Checker. We are very much interested in

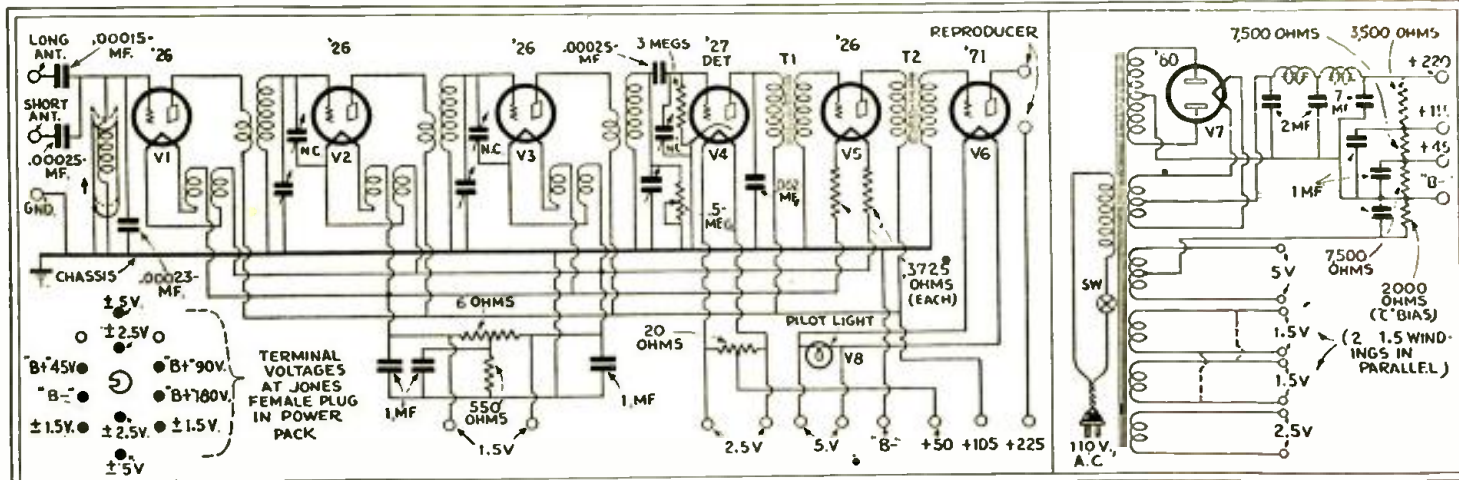

Fig. Q128 (Above)

The Sonora "Model E-AC" circuit is substantially an earlier battery-model Sonora receiver, redesigned for A.C. operation. Note the filament chokes; and the "trombone" antenna inductance trimmer.

Fig. Q128 A (Above)

Power pack connections for the Sonora "Model E-AC." The terminal markings are only approximate indications of output values.

# Announcement!

## OFFICIAL RADIO SERVICE MEN'S ASSOCIATION

**E**VER since the appearance of the commercial radio broadcast receiver as a household necessity, the Radio Service Man has been an essential factor in the radio trade; and, as the complexity of electrical and mechanical design in receivers increases, an ever-higher standard of qualifications in the Service Man becomes necessary.

The necessity, also, of a strong association of the technically-qualified radio Service Men of the country is forcing itself upon all who are familiar with radio trade problems; and their repeated urgings that such an association must be formed has led us to undertake the work of its organization.

This is the fundamental purpose of the OFFICIAL RADIO SERVICE MEN'S ASSOCIATION, which is not a money-making institution, or organized for private profit; to unite, as a group with strong common interests, all well-qualified Radio Service Men; to make it readily possible for them to obtain the technical information required by them in keeping up with the demands of their profession; and, above all, to give them a recognized standing in that profession, and acknowledged as such by radio manufacturers, distributors and dealers.

To give Service Men such a standing, it is obviously necessary that they must prove themselves entitled to it; any Service Man who can pass the examination necessary to demonstrate his qualifications will be elected as a member and a card will be issued to him under the seal of this Association, which will attest his ability and prove his identity.

The terms of the examination have been drawn up in co-operation with a group of the best-known radio manufacturers, as well as the foremost radio educational institutions.

The following firms are co-operating with us:  
GRIGSBY-GRUNOW CO (Majestic), CHICAGO  
STROMBERG-CARLSON TELEPHONE MFG. CO., ROCHESTER, N. Y.  
CROSLY RADIO CORP., CINCINNATI, OHIO  
COLIN B. KENNEDY CORP., SOUTH BEND, IND.

The schools who have consented to act as an examination board are:  
International Correspondence Schools, Scranton, Penna.; Mr. D. E. Carpenter, Dean.  
RCA Institutes, Inc., New York, N. Y.; Mr. R. L. Duncan, President.  
East Bay Radio Institute, Oakland, Calif.: Mr. T. T. Tonnehilt, Director.  
Radio Training Association of America, Chicago, Ill.; Mr. A. G. Mohaupt, President.  
School of Engineering of Milwaukee, Milwaukee, Wisc.; Mr. W. Werwath, President.  
Rider-Goll Radio School, New York, N. Y.; Mr. John F. Rider, Director.  
Radio College of Canada, Toronto, Canada; Mr. J. C. Wilson, President.  
Radio Division, Coyne Electrical School, Chicago, Ill.; Mr. H. C. Lewis, President

We shall not attempt to grade the members into different classes. A candidate will be adjudged as either passing or not passing. If the school examining the papers passes the prospective member as satisfactory, we shall issue to him an identification card with his photograph.

If the candidate does not pass this examination the first time, he may apply for another examination three or six months later.

There is absolutely no cost attached to any service rendered by the Association to its members, no dues, no contributions.

If you wish to become a member, just fill out the coupon below and mail it to us. We will send you all the papers necessary to become a member.

O. R. S. M. A.,  
c/o RADIO CRAFT, RC-8  
98 Park Place,  
New York, N. Y.

I wish to become a member of your Association. Please mail me the examination papers and application blanks.

Name .....  
Address .....  
Town..... State.....





this device; but, in order to determine its adaptability to our requirements, we ask that you print its circuit arrangement.

(A1) Fig. Q129 shows the schematic circuit of the DayRad "Type L" Self-biasing Tube Checker; this is the latest available design of this instrument.

The sockets take tubes as follows: V1, '24, '27; V2, '26, '30, '31, '32; V3, X12, '36, '37, '38; V4, '45, '20, '99, '22; V5, '01A, '12A, '71A, '30; V6, '10, '50, '81. Output terminals give 3 and 15 volts.

Only the following readings are furnished. To test other types, it will be necessary to make a checkup test of three or four of these tubes to determine average readings; and include these figures in the following list. "Min." indicates the minimum difference reading, which marks the "End of life." The tube should exceed this figure in proportion to its expectancy of Service.

Type	Min.	Type	Min.	Type	Min.
'24	9	'20	2	'50	20
'27	13	'30	1	'01A	3
'45	18	'31	3½	K-12	3
'71A	18	'32	1	'26	5½
'12A	8	'22	4	'80	*34
'99	½	'10	10	'81	34

\* Each plate.

(Q2) I have a Kingston "Type 2" eliminator. Please advise the range of the two variable resistors.

(A2) Two "universal range" resistors are used in this "B" eliminator, in the positions shown in the schematic diagram (Fig. Q129A.) The rectifier is a "B1" or gaseous-type tube. The power-line resistor may be set to take care of differences in line-voltage.

**BOSCH "PERSONAL" SET**

(130) Mr. N. E. Karig, Holden, Maine.

(Q.) Is there available a schematic diagram, showing the connections employed in the Bosch "Personal" Radio receiver?

(A.) The schematic circuit of this receiver, a general description of which appeared on page 21 of the July, 1931 issue of RADIO-CRAFT, is shown in Fig. Q130.

The circuit values are as follows: condenser C1, antenna trimmer; C2, C3, C4, tuning condensers; C5, C6, alignment condensers; C7, C8, coupling condensers; C9, A.F. coupling condenser, .006-mf.; C10, .0001-mf.; C11, C12, C14, .05-mf.; C13, C16, 0.25-mf.; C15, 1-mf.; C17, .01-mf.; C19, C21, 4-mf.; C20, .08-mf.

Volume control resistor R1 is 10,000 ohms; R2 300 ohms; R3, R9, R10, 50,000 ohms; R4, 2 megs.; R5, 1 meg.; R6, ½-meg.; R7, 100,000 ohms; R8, center-tap resistor; R11, 10,000 ohms; R12, 400 ohms.

The socket voltages as read on a high-resistance analyzer will be approximately as follows: filament potentials, V1, V2, V3, V4, 2.3 volts; V5, 4.8 volts. Plate potentials, V1, V2, V4, 250 volts; V3, 150 volts.\* Plate currents, V1, V2, 4.5 ma.; V3, 0.5-ma.; V4, 32 ma.; V5, each plate, 20 ma. Screen-grid potentials, V1, V2, 90 volts; V3, 20 volts\*; V4, 250 volts. Cathode potentials, V1, V2, 2.5 volts; V3, 3 volts. Control-grid potentials, V1, V2, 2.5 volts; V3, 1.5 volts; V4, 16 volts.\*

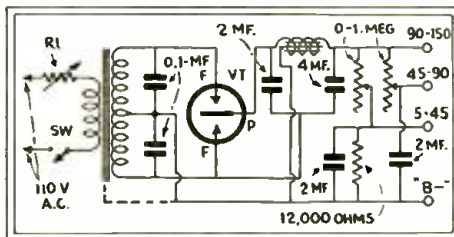

Fig. Q129A

Kingston "Type 2" eliminator; R1, 200 ohms.

\* These are the true voltages; although some test kits may indicate as low as 1/10th these values, because meters of lower resistance are operating in high-resistance plate circuits. The above readings were made with the volume control in the full "on" position.

Note that, when the volume control's setting is reduced, the R.F. plate voltage will remain constant; while the screen- and control-grid and cathode voltages will increase.

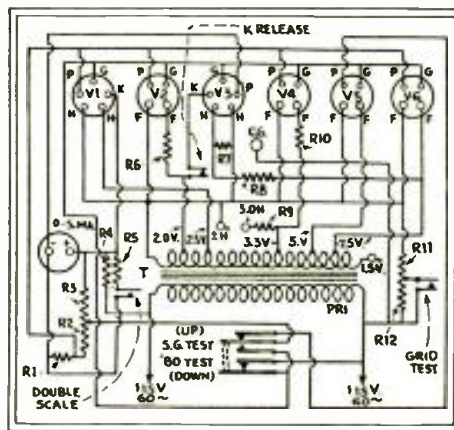

Fig. Q129

DayRad "Type L" tube checker. R1, 150 ohms; R2, 28.5; R3, 71.5; R4, 750; R5, 18.7; R6, 0.47; R7, 20; R8, 2.66; R9, 0.14; R10, 0.362; R11, 400; R12, 2250. Meter, 0-40-ma. Weston "572."

**VOLUME-CONTROL DATA SHEET**

A HANDY guide for the Service Man is found in a folder recently issued by Electrad, Inc., which contains a table of the variable-resistor and potentiometer types which may be used to replace the controls in most of the well-known receiver models; with a keyed guide to circuit diagrams showing the twenty methods which are used. Other resistor data are given in the folder, which is a single sheet of stout manila board folding to 4½ x 10¼ inches, and will slip into the coat pocket or the kit. It is distributed to the trade.

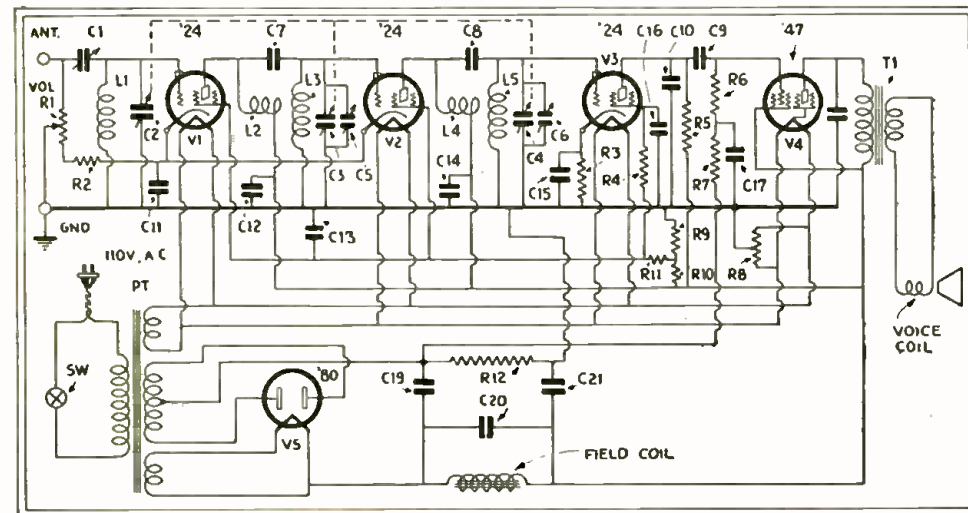

Fig. Q130

Bosch "Personal" receiver, Models 5A, 5B and 5C; some chassis are wired for a '45 at V4; others have variable-mu '51s at V1 and V2. The bypass of V4's plate is .01-mf. C1, mounted on the reproducer frame, is to be adjusted at a dial reading between 10 and 40.

**Recording for Profit**

Editor, RADIO-CRAFT:

I have read the articles on "Instantaneous Sound Recording" in RADIO-CRAFT, which is sure a fine little magazine for the wide-awake Service Man. I am in the radio business in any and all of its branches; especially public-address systems and recording. I would appreciate information on manufacturers of recording apparatus and accessories. Fiber needles have been my greatest problem; for the average fiber needle will not quite fit into the new magnetic pickups. The thorn needle is very good, but the price is high.

I have experimented with various discs; and agree with Mr. Saliba that a volume indicator is absolutely necessary if good recording is to be done, since the human ear is a mighty poor judge of volume.

As for the possibilities of personal recording, I think there are many; especially for the parks during the summer season. Also, renting a booth in a good live music store. One good idea, I believe, is to set up a booth and to display a sign which reads "Voice Tests for the Talkies"; a one-minute record for say 25 cents. How many young girls are there who will not spend a quarter for that? Personally, I think there are very few; for human beings are all more or less vain.

Another way would be to set up a good-sized studio, with a piano, of course, and mail cards to any local orchestras, music teachers, etc. In fact, there are hundreds of ideas, all which will bring a good profit.

THOMAS F. COLSON,  
Colson Sound Studios,  
Amsterdam, New York.

**TAPPING MUSIC AT THE SOURCE**

BRINGING the church into the home was almost literally accomplished at a recent wedding in Montclair, N. J. The bride wanted "a home wedding with church music"; and the radio Service Men rigged up an amplifier which accomplished the stunt when connected to the church's organ.

**ANOTHER OF THOSE THINGS**

WHEN you lean against the gas buggy of Tumpo, the radio magician, a phonograph attachment asks, "Whaddya mean leaning up against me that way?"

—Variety.

**RADIO EMPLOYMENT WANTED**

Service man, connected with radio work since 1921, desires connection with radio or sound-picture concern. Experienced in installing and servicing sound equipment. Also projection work. Experienced on all makes radio receivers. Junior member, I. R. E.; member National Sound Service Bureau. Will go anywhere. Leo G. Sands, 2119 McDougall Ave., Everett, Wash.

**SMALL-TOWN PEOPLE LISTEN LONGER**

THAT 85% of the radio stations answering believe small-town people listen longer to radio broadcasting than people in cities; 69% believe there are as many good radio sets in small towns as in cities; 53% of the fan mail comes from small towns; and 72% of all fan mail comes from women are facts brought out in a recent poll of twenty-nine radio stations in twenty-two states, by *The Household Magazine*.

As a checkup to learn the radio-mindedness of small-town people by direct investigation, a survey of thirty-seven states showed that 61% of the small-town families own receivers and that 66% of these are electric sets.

# The Radio Robot

(Continued from page 77)

power relay No. 2. This is connected to throw the switch turning on the electric phonograph system outlined in Fig. 8. The other circuits are controlled in exactly the same way. *By increasing the number of selective tuning circuits, it is possible to increase the number and variety of acts of the "Iron Man."* If several acts are to be performed *simultaneously*, the master relay may be arranged to close a circuit actuating a number of "final" relays connected in series; that is to say, the relay causing him to stand up, the one turning on phono motor, etc., may be connected in series.

During the sequence of operations directed by the phonograph record (Fig. 9), it is possible to interrupt at any time and to produce any desired changes. If it is desired to make the robot move his head, arms, etc., at any particular point (not previously pre-determined by the note on the record), this can be done readily by merely throwing the proper "manual control switch." A single-pole double-throw switch permits the head to be turned to the right or to the left (depending on which way

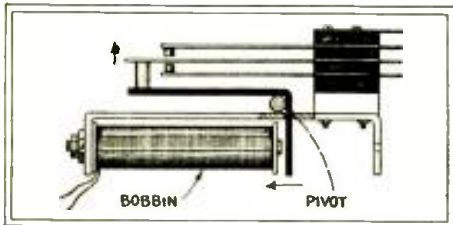

Fig. 11

Switchboard relays, which act as S.P.D.T. switches, are suitable for the robot; the bobbin may be rewound, if necessary, to give a correct value for the circuit.

the switch is thrown). The recorded speech may also be interrupted, and any other speech substituted, by switching off the phonograph and switching in the microphone (See Fig. 8.) The operator then talks into the microphone, substituting his own speech for that of the phonograph record.

### Control by Light Signals

The "static amplifier" which was used in connection with the light-sensitive cell, is shown in Fig. 10; this used a '24-type tube V1, and a '27 output tube, V2; the latter connected to a relay. (Although the plate impedance of V2 is about 9000 ohms, good results may be obtained by using a relay of considerably lower impedance.) A common type of relay, used on telephone switchboards, and available in various resistances and contact combinations, is illustrated in Fig. 11.

If the robot is to be used out of doors in the daytime, the exciting beam may be furnished by the sunlight; when the day is bright, it is necessary to use a red or blue color filter, or a semi-transparent reduction mesh. On a cloudy day, the light from the south is employed.

When the demonstration is given indoors, or outdoors at night, a light beam from a small electric bulb is required.

In any case, a reflecting mirror is needed. It is desirable to make this portable, so



\$5

Postpaid

The Best \$5.00 Investment You Ever Made

### This Is Why

Endorsed by New York and Philadelphia Radio Service Manager's Associations.

Approved by leading radio manufacturers.

974 pages of accurate, authentic service information. 1800 diagrams.

Schematic wiring diagrams—chassis diagrams—electric values—socket layouts—color coding of connecting wires and resistors—continuity of units in sealed cans—loud speaker data—peculiarities of commercial receivers.

Complete, practical troubleshooting methods used by set manufacturers.

A detailed account of principles and application of set analyzers.

Service data covers commercial broadcast receivers, short-wave receivers, power amplifiers, eliminators and power packs, oscillators, midjet sets and Canadian receivers.

FREE question and answer service.

Supplementary Monthly Data (96 pages minimum), keeps basic manual always up-to-date.

Simple, quick index.

Satisfaction guaranteed or money refunded.

# 974 Pages of RADIO SERVICE INFORMATION

For the Service Man Who Must KEEP UP With Radio Progress to Make His Business MORE PROFITABLE

JOHN F. RIDER'S classic—a whole service library in one loose-leaf volume, with FREE QUESTION and ANSWER SERVICE—and SUPPLEMENTARY MONTHLY INFORMATION that keeps you up-to-date for a moderate fee.

Radio service is the sale of knowledge and time. This book increases your knowledge and saves your time. With it, your patronage grows—your profits pile up.

### Use Your Head

Don't be fooled by offers of "complete" service manuals. No manual can be complete in an industry that is constantly progressing, unless it keeps up with that progress. The 1931 TROUBLE-SHOOTER'S MANUAL is the basic unit of a perpetual service library. It is the only manual of its size and scope—and with its supplementary feature of 80 pages of NEW Radio and 16 pages of Electric Refrigeration, Home Talks and Public Address Systems Data each month, it keeps you FULLY INFORMED at all times—next month, next year, the next ten years—about all you must know in order to run your business successfully.

The 1931 TROUBLE SHOOTER'S MANUAL is fully guaranteed. You are the judge of its value. If you don't think it is all we have represented—if you feel that you can afford to be without it—send it back and get your money. No quibbling.

### Supplementary MONTHLY INFORMATION

Not less than 96 pages of NEW information mailed to subscribers each month—to KEEP them up-to-date. This thorough service costs for one year, only \$1.25 per month in installments. Only \$9 a year, cash in advance.

RADIO TREATISE CO., Inc.  
1440 BROADWAY,  
New York, N. Y.

MAIL YOUR ORDER TODAY  
RADIO TREATISE CO., Inc., 1440 Broadway, New York.  
Enclosed \$5 for 1931 TROUBLE-SHOOTER'S MANUAL.  
Enclosed \$9 for one year's subscription to SUPPLEMENTARY MONTHLY SERVICE.  
SEND MY ORDER HERE. Payment for monthly service here if installment payment for monthly service desired. Check here for detailed circular. Check Name Address

Soft Aluminum Pregrooved Blank Records for Instantaneous Home Recording. Double Faced.

Give Volume Brilliancy Durability

List Prices  
4 inch \$0.50  
8 inch 0.75  
10 inch 1.00

Also Microphones—Double and Single Button, Transformers, Mounts, Cable, Plugs, etc. New 32-Page Catalog just out.

UNIVERSAL MICROPHONE CO., Ltd.  
Inglewood Dept. R.C. California

Makes Your Radio BEHAVE!

For Every Set

AMPERITE corrects line voltage variations. Installed in 5 minutes. No chassis changes. Write Dept. RC-8, giving make and model number of your set.

AMPERITE Corporation  
561 BROADWAY, NEW YORK

Self-Adjusting LINE VOLTAGE CONTROL



... set testing reduced to *Simplicity* with the New

*Readrite*

analyzers

ACHIEVEMENT in perfecting and simplifying testing equipment for servicemen, dealers and experimenters is still of prime importance—and for the past twenty-seven years Readrite engineers have periodically placed on the market testing equipment of advanced design. Good testing equipment today is indispensable—and for rapid adjustments, expert servicing and testing, Readrite products are increasingly being demanded. Investigate the advantages of using Readrite equipment—the products that have been sold for over a quarter of a century.

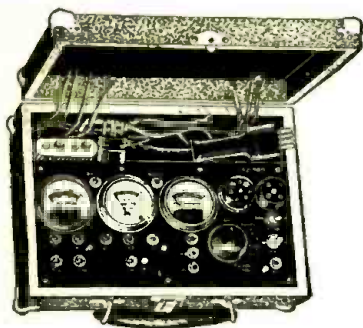

Model 700

THE MODEL 700 Meter is equipped with a practical selector switch for checking all parts of the tube circuits by connecting to the set sockets. Selection for testing voltages of plate, grid, cathode and screen-grid is done quickly and accurately. Plate current, filament volts, also line and power supply volts are measured. The grid swing test for tubes is used. Just push one button for screen-grid and another button for other tubes. Makes testing of all type tubes simple and thorough. A 4½ volt grid battery is furnished. The battery is used for the grid test and also continuity testing of transformers, chokes, etc. Capacity and resistance charts are furnished showing the use of instruments for testing condensers, also measuring resistances up to 100,000 ohms. The eight scale readings of the meters may be used separately with jack terminals provided. The scale readings are 0-60-300-600 D. C. volts, 0-10-140-700 A. C. volts and 0-20-100 milliamperes. Both A. C. and D. C. filament voltages are accurately measured on one meter.

This model is housed in a strong case with leatherette covering; it is attractive and compact, as well as complete. Cover is removable. It fills every need for the expert serviceman or the beginner for radio set analyzing. Size 10¼ x 3½ x 8 inches. No. 700 List Price \$25.00

**MODEL 600**

contains exactly the same testing equipment as No. 700 but the carrying case is much larger and is equipped with a lock. Room is provided for carrying tubes, tools and supplies. The test equipment and panel is in a removable tray in the top of the case. The tray may be used separately as a complete test panel for shop purposes. Size 14½ x 7 x 7½ inches. No. 600 List Price \$30.00

Send for Catalog "R"—or Order Your Meters NOW!

If not at your jobbers order direct. Discount to dealers and service men.

**READRITE METER WORKS**

17 College Ave. Bluffton, Ohio  
Manufacturers of Accurate Testing Instruments Since 1904

that no undue trouble will be experienced in moving the device from one place to another. For this reason, the reflecting mirror and the exciting-lamp assembly should be mounted on a surveyor's tripod, or similar arrangement. A screen or sheet steel, with a very dull black finish, is used as a screen; so that no light other than that from the mirror may be projected upon the photoelectric cell. A ring sight and a sighting hole through the screen assist in lining up the assembly.

The values for Fig. 10 are as follows: R1, 0-10,000 ohms; R2, 1,000 ohms; R3, 10,000 ohms, 1-watt; C1, 1 mf.

The milliammeter MA, shown in the plate circuit of the output amplifier tube, is essen-

tial for intelligent operation of the amplifier. The potentiometer R1 provides a suitable means of regulating the plate current; since the circuit is operated intermittently, the plate voltage should be adjusted to give the amplifier tube a plate current greatly in excess of its continuous rating. This permits the use of a relay of much lower impedance and, hence, higher current requirement, than would be possible if the plate impedance of the '27 tube had to be matched.

The relay, actuated by the photo-cell, was then used to operate the relays which produce mechanical motion, which turned on the electric phonograph or produced any of the other actions described above.

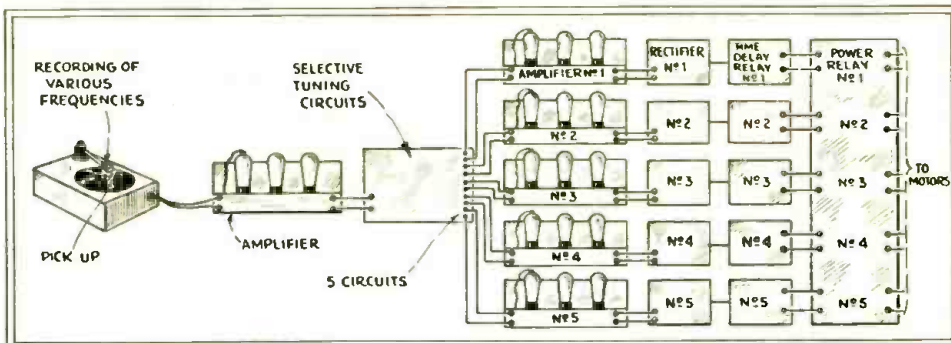

Fig. 9

A complex control method utilizing numerous recorded control-frequencies which are push-button selected. The general application is illustrated in Fig. 2, in the preceding issue

**The Stenode System**

(Continued from page 94)

divided complex wave—and all will bring us finally to the same point.

However, when a carrier, or continuous radio-frequency wave, is modulated by audio frequencies of varying pitches, timbres and intensities, the effect we call "sidebands" is created; if this carrier, so modulated, is received by a properly-tuned circuit connected to a faithful amplifier and reproducer system (including of course a detector) the modulations are reproduced in their original form—the carrier wave being cancelled out. Furthermore, with a system of this kind, the result of tuning which is "too sharp" is to suppress the higher tones in the output; this fact was early discovered in the effort to obtain selectivity through cascaded R. F. amplifiers.

As a practical compromise, it has been assumed that audio tones above 5,000 cycles may be dispensed with in radio reproduction; that spacing the carrier-wave frequencies of broadcast stations ten kilocycles (10,000 cycles) apart will then prevent their interference; but that the number of broadcast stations is thereby naturally limited and, to increase their number, the quality of broadcasting must needs be reduced.

So, to make full use of the ten-kc. broadcast channels, for musical transmission, it was necessary that receivers should be correspondingly designed. We therefore find in modern receivers the "flat-top" band-pass filter; designed to permit practically equal amplification of all the sidebands, and proper reproduction of the higher audio frequencies.

It therefore seemed like flying in the face, not merely of tradition, but of the laws of nature, when Dr. Robinson produced his Stenode and proposed to receive the program of a broadcast station, with all the high tones of articulated speech and overtones of its musical instruments, yet without the aid of its sidebands. The public, and even the radio experts, had been so long told that they must choose between sensitivity and selectivity, and that they must give up one, so long as they demanded the other, that the proposition seemed incredible.

**Restoring the Quality**

Yet the fundamental principle is a simple one; that, even though the sidebands are cut off, by a circuit tuned far more sharply

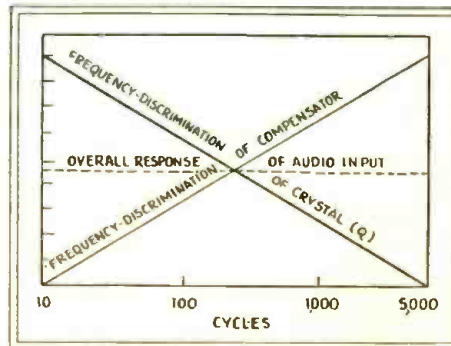
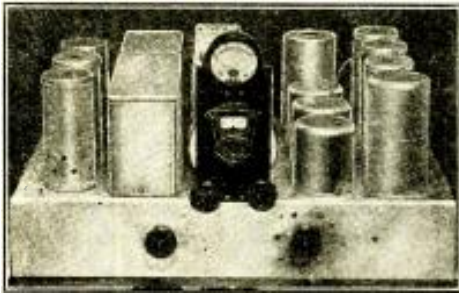

Fig. 3

The principle (though not the actual curve) of the Stenode's compensator is shown here. It brings up to proper volume the high notes suppressed in the crystal circuit.





One of the Stenode laboratory models, of the type familiar in commercial superheterodyne chassis. The crystal-tube is shielded, like the others.

than the standard three- or four-stage R. F. amplifier with its low-loss coils and condensers, and only the naked carrier is received, that carrier is still modulated, if only by the ghosts of its sidebands. And, after that carrier has been separated from all interference, those sidebands can be restored to their full original values by the employment of proper compensation in the audio amplifier.

There is no gain without some loss; when the higher frequencies have been brought down to the points of suppression, additional amplification is needed to bring them back up to full value. But, in the standard modern receiver, there is already a high reserve of amplification which is thrown away (as in the volume control, the variable- $\mu$  tubes, etc.) simply for the purpose of getting rid of interference. This reserve may well be transferred to the audio end.

What advantage is thus gained? Has it been simply a matter of filling Paul's pockets at the expense of Peter? No.

The selectivity thus gained in the R. F. channel has enabled us to escape, not only the interference of adjacent stations, overpowering in the urban areas containing the largest number of receivers, but also a large portion of the thousand and one other forms of natural and artificial interference. Since the last named are distributed over all parts of the broadcast spectrum, the narrower our tuning, the greater will be the ratio of signal to static. In this connection, Fig. 1 is of interest.

The two outer curves are those, respectively of a high-grade "band-selector" R. F. receiver and of a high-grade superheterodyne, as plotted by their manufacturers. According to the previously-accepted principles of design, they present the most favorable compromise of selectivity with quality. The dark, shaded center area is the selective curve of a Stenode, as determined in the laboratory of a large manufacturing company which was testing it. It is a visible demonstration of literal "razor-edge" selectivity.

This curve is obtained, as explained in previous articles, by the introduction of a quartz crystal or "gate" (Q) into the intermediate-frequency amplifier of the Stenode (Fig. 2). The crystal has an extremely well-defined natural frequency of its own, serving here to pass signals very close to that value and to suppress others almost completely.

The crystal is the heart of the Stenode circuit. To grind it to an exact assigned frequency, as done for a transmitter, would be a work of very exacting nature; but it suffices to bring the crystal approximately

to a frequency of 175 kilocycles (which is in accordance with American commercial superheterodyne practice), and then to adjust the amplifier to the small extent necessary to give maximum efficiency with the particular crystal.

The frequency of the intermediate amplifier being thus determined, it is necessary merely to tune the frequency-changer (of any standard type) to the carrier of the station which it is desired to receive, and to bring the oscillator frequency along with it until the intermediate frequency reaches that of the crystal gate. This is a point of great exactness; with an ordinary dial, the station would jump in and out almost simultaneously.

**Precision Tuning Controls**

Amateurs and short-wave fans are familiar with fine tuning; but the broadcast listeners of today have not been brought up to this necessity. However, to meet the situation, the Stenode engineers have worked out a tuning dial with a super-vernier; and this will be put on the market by one or more manufacturers. It has a ratio of 10 to 1, for "rough" adjustment; and of 200 to 1 for the fine setting required to hit a station "right on the nose." An extremely low capacity trimmer is adjusted for the oscillator. When this is done, the astonishing freedom from background noise and the clearness of reproduction are quite surprising, well worth the added control.

The next question arises, what is to be done with this "razor-edged" selectivity? (From an ordinary receiver, it is obvious, there would be no reproduction whatever of speech.) The answer is found in a compensating circuit which brings up the detector output on the high tones and suppresses it on the low tones; thus exactly reversing the effect of the crystal on the modulated intermediate-frequency signal. The idea is illustrated, without reference to an actual characteristic curve, in Fig. 3. The output, if amplified in the ordinary way, would be all low-note—lower perhaps than the lowest musical tone; while an ordinary receiver, feeding into the Stenode coupling device, would give nothing audibly but the highest whistles. The composite effect of the two is to produce a straight line, theoretically; as a matter of fact, straight lines are not found in practical radio engineering, and the output overall characteristic of the receiver shows the rises and dips usually associated with an output of high quality.

**Crystal-Control Tubes**

The crystal, it was observed, is the heart of the Stenode. Any type of frequency changer, built with the necessary fine-tuning controls, may be used; and any type of intermediate amplifier, the tuning of which also need not be critical. The audio amplifier after the compensating coupler may be of any type; it is interesting to note that certain audio devices of poor quality (because of their discrimination against low notes) have been found very useful in making up experimental models, in which their former failings became virtues.

The first crystals employed in Stenode models were ground to a low intermediate frequency; but those employed in later work conform to American practice. A number were manufactured in England, under the

**Make the most of your Meters by using I. R. C. Precision Wire Wound Resistors**

This instrument is easily and inexpensively built by following the instructions in I. R. C. Volt-Ammeter Adapter Kit.



ONE of the most useful instruments you can possess is the Volt-Ammeter Adapter. It makes eight different meters from one, simply by turning a dial.

Do you know that with a kit of eight I.R.C. Precision Wire Wound Resistors, you can easily make this valuable apparatus yourself? Ask your jobber for the necessary resistors, and our complete wiring diagrams telling just how to go about it.

This is but one of the services of the International Resistance Company to save you money. And you will find that I.R.C. Resistors have greater dependability, no matter what uses you put them to. They are calibrated to an accuracy of 1% or better and are used as laboratory standards by the foremost engineers.

Consult us on your resistor problems. Write for data on other I. R. C. money-saving helps.

INTERNATIONAL RESISTANCE CO. Philadelphia Toronto

**I R C PRECISION WIRE WOUND RESISTORS**

Also I. R. C. Metallized Resistors

INTERNATIONAL RESISTANCE CO. C-8 2006 Chestnut St., Philadelphia

Please send me 4-page folder containing full construction details on how to build a Volt Ammeter Adapter.

Name \_\_\_\_\_  
 Address \_\_\_\_\_  
 City \_\_\_\_\_ State \_\_\_\_\_



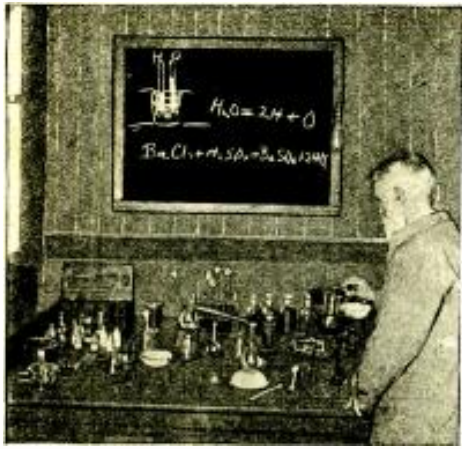

## Dr. T. O'CONNOR SLOANE Will Teach You at Home!

ANYONE WHO CAN READ AND WRITE can study Chemistry through our simply prepared course. You don't need a higher education, and you don't need any previous experience or preparation. Chemistry is not harder to understand than electricity or radio. Just plain sense and ordinary observation powers.

### We Can Teach You At Home

Our faculty knows just how to mold you into a skillful laboratory worker. THE HEAD OF OUR STAFF IS DR. T. O'CONNOR SLOANE, scientist, engineer and author of wide repute. He has had more than fifty years of teaching experience. Our course fits you for an immediate position in a chemical laboratory, and you do not have to give up what you are doing now to learn it. During evenings and week-ends you can work at home on the fascinating experiments and the delightfully simple but comprehensive lessons.

### Laboratory Outfit Free

THE COMPLETE CHEMICAL OUTFIT and APPARATUS supplied to you as part of your course, without extra charge, makes you the owner of a laboratory, containing all the materials and instruments used by a full-fledged chemist. This working kit, which is shipped to you at the outset of the course, becomes your permanent property. It is a sturdy fitted wooden cabinet containing over 100 pieces of laboratory apparatus and chemical supplies.

### Big Money in Chemistry

CHEMISTS ARE WELL PAID MEN. Not only will our training help you to get a better job, but a worthwhile start on a new level. You can patent the work of your hands and your brain, and perhaps make millions of dollars on a new chemical discovery. Every day the newspapers and magazines are full of new items reporting new chemical discoveries—in mining, in electricity, in foodstuffs, in sanitary and medicinal appliances, in paper-making, rubber, steel, iron, dyestuffs, textiles, in fact in every well known industry—and behind each of these discoveries stands a well-trained chemist who knew how to take advantage of opportunity!

### No Exaggerated Claims

THE INSTITUTE DOES NOT CLAIM that every chemist makes millions, nor do we guarantee that you will immediately get a job paying \$10,000 a year. But many have done it and there is no reason why you can not do it too. Often enough you read or hear about men who have found the highest recognition, from small, inconspicuous beginnings, and you wonder how they got the "lucky break." Why, you wonder yearningly, couldn't you be such a "lucky" fellow? You can be—but you have to meet luck half way.

### Get Started Today!

IF YOU WOULD LIKE TO KNOW MORE ABOUT CHEMISTRY, and if you are sincere in your desire to get out of the treadmill of job anxiety and wage dependence, if you have ambition enough to want to become a chemist, and perhaps a famous one some day, you will not wait until tomorrow to find out how to go about it. MAIL the coupon below today. There is no charge and no further obligation. You will be simply asking us to write you about something that you want to know.

Chemical Institute of New York, Inc.  
Dept. RC-831  
19 Park Place, New York, N. Y.

Please send me at once, without any obligation on my part, your Free Book "Opportunities for Chemists," and full particulars about the Experimental Equipment given to every student.

NAME .....

ADDRESS .....

CITY..... STATE.....

direction of the British Radiostat Corporation, which first brought out the Stenode; and it is one of these which is illustrated in Fig. A. Arrangements, however, were completed recently for their manufacture in America. The vacuum-tube mounting shown is the most efficient method of protecting the crystal and ensuring it practically unchanged operating conditions.

The Stenode Corporation, which is introducing the new system, is a holding and development corporation only, and not a

manufacturer. It is stated that, within a very short time, several types of kits and commercial receivers will be available from their licensees. Other developments, such as Stenode television receivers, for which special high-frequency compensators will be necessary, and Stenode telegraph and printing equipment, especially for land-line work, are still in the laboratory stage; but promise to be highly interesting. RADIO-CRAFT will as usual, keep its readers informed as new developments come up.

## Volume-Control Replacements

(Continued from page 95)

is to be recommended where there is space for the deeper unit.

Fig. 6 is practically the same as Fig. 5; except that separate units are employed for the "C" bias and the antenna. The biasing unit may vary the grid voltage of all of the R. F. tubes, if desired. A 75,000-ohm unit mounted on the same shaft as the 10,000-ohm antenna unit is made for this purpose (the PR5-10-75A volume control). If more than two tubes are controlled by the one biasing resistor, wire-wound Clarostats are recommended; in which case a 50,000-ohm resistor may be substituted.

The antenna and screen-grid voltage control with a double unit (Fig. 7) is preferred by many manufacturers; for it is thought to be less likely to affect the tone quality than the method of Fig. 6. The antenna unit may be hooked up according to the circuit of Figs. 2 or 4, if preferred. By varying the screen-grid voltage of the R. F. tubes, the sensitivity of the amplifier is varied together with the variation of the signal input. A duo-control unit (PP5-10-50A), with a 10,000-ohm antenna resistor and 50,000-ohm voltage divider resistor, is recommended. If wire-wound resistors are desired, the 20,000-ohm Clarostat should be used for the screen-grid voltage control.

Fig. 8 shows the volume-control method employed in the Victor R-32 and RE-45 receivers. One unit controls the antenna signal input, and the other shunts an R. F. absorption coil which is coupled to one of the following tuning units. A special duo wire-wound unit (the V-32) is made for this circuit.

### Other Methods of Control

A common method of controlling volume when using screen-grid tubes is shown in Fig. 9; a potentiometer is employed to vary the screen-grid voltage. The 50,000-ohm graphite unit (P5-50A) is extensively used for this purpose; although the wire-wound 20,000- to 30,000-ohm resistors will stand up better under the heavy bleeder current.

Fig. 10 is somewhat similar to Fig. 4, except that the unit shunts one of the R. F. transformer primaries; a 100,000-ohm tapered resistor (the R5-100A), is recommended for this circuit. This is a simple method of volume control, employed in many old radio sets, but it has the disadvantage of broadening the tuning.

A better method is illustrated in Fig. 11; here a lower-resistance potentiometer is employed, such as the P5-10A, 10,000 ohm one. (It varies both the plate D. C. and the R. F. energy transfer—Tech. Ed.)

In receivers not using screen-grid tubes,

one of the most effective methods of volume control is shown in Fig. 12; this method varies the plate voltage applied to one or more of the R. F. tubes. It permits of operating the tubes at the optimum point of their characteristic, and makes a simple oscillation control—grid suppressors and other forms of "lossers" being unnecessary. A wire-wound Clarostat is recommended by the writer for this circuit, because of the heavy current flowing through it. A 20,000- to 30,000-ohm resistor is usually employed; the correct value depending upon the plate voltage and number of tubes under control.

The circuit of Fig. 13 produces the same effect as that of Fig. 12; however, instead of shunt-connecting the resistor, a series connection is used. Therefore, a resistance of much higher value, about 500,000 ohms, is necessary. Carbon compression or graphite types may be employed, the P5-500A being suitable.

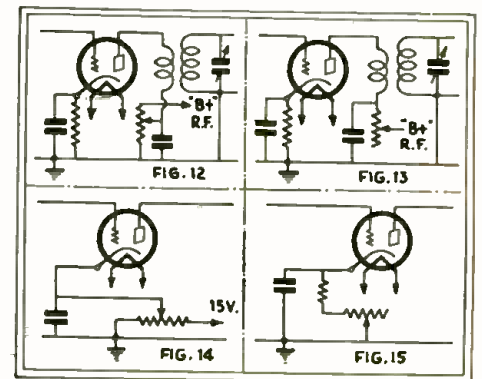

Above, potentiometer and rheostat plate-voltage control. Below, potentiometer and rheostat control of cathode bias. The fixed resistance sets a minimum negative bias.

A "C"-bias potentiometer method of volume control is illustrated in Fig. 14. Wire-wound resistors are necessary in this circuit because of the heavy tube and bleeder or "waste" current. Since this resistor is usually part of the voltage-divider circuit, when substituting a volume control for a bias resistor, one having the same resistance and current-carrying capacity as that removed should be employed.

A series resistor may be used in the "C" bias circuit, as in Fig. 15; here a resistance much higher than that used in the circuit of Fig. 14 is necessary, one of 75,000 ohms being about right. This is similar to part of the circuit of Fig. 6 but, of course, not as critical.

### A. F. Volume Controls

Although it has been previously stated that volume controls should not be placed in the audio amplifier circuits because of

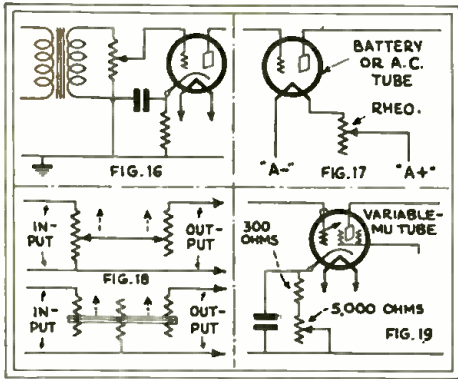

Above, old methods of volume control; below, two of the latest systems. See the text.

the possibility of overloading the detector, there are cases where it is necessary to use a volume control in an audio circuit. For instance, in using the audio amplifier for amplifying phonograph music, or for home recording, no R. F. amplifier is employed; and the volume control must be placed somewhere in the audio circuit. Fig. 16 shows one common method. It consists of a potentiometer (usually 500,000 ohms) connected across the secondary of one of the audio transformers. This method was used on many old radio sets; but it should be replaced or supplemented by one of the methods previously described, unless the set is used for phonograph amplification. In any event, a volume control for the radio end should be installed.

Another method of volume control found in many old receivers, both battery and A. C., is shown in Fig. 17; here a rheostat is used to vary the filament temperature. Whenever a set of this type is encountered, it is advisable to install a modern volume control, as in circuits 2, 3 or 13, and adjust the filament rheostats so that rated filament current is obtained.

In Fig. 18 are shown two circuits gener-

ally employed in sound amplifiers, phonograph pick-ups, microphone circuits, and wherever more than one loud speaker is operated from one amplifier. In these circuits, it is necessary to control the volume of one instrument without changing the impedance of the other circuits or affecting them in any way. The fader, as used in sound projection installations, for fading in one pick-up or the other, employs this general type of circuit.

By using two or three potentiometers on one shaft, various combinations are possible. It is customary to design the circuit so that the load on the input device remains constant, regardless of the adjustment of the control knob. Many combinations are possible; but the present demand is for 25-, 200-, 500-, and 50,000-ohm "constant-impedance" units.

From the foregoing, it is apparent that the Service Man should be well informed regarding the various resistance units available and the generally accepted circuits for using them. The subject of volume control is an important one, so much so that new developments are still under way. Many of the latest receivers employ the new variable-mu tubes for the purpose of controlling volume without introducing distortion, caused by cross-modulation from local stations. This means that the Service Man will be called upon to install these tubes, in older sets, and he must also install the proper volume controls with them. Fig. 19 is the recommended circuit. A "C" bias control is employed, comprising a fixed 300-ohm resistor in series with a 5,000-ohm variable wire-wound unit.

The average radio set owner usually calls in a Service Man as he would call a doctor; after it is too late, or when something drastic has happened. There are millions of radio sets that can be improved with a few modern refinements; and Service Men find it profitable to investigate this angle.

## Short-Wave Coil Data

(Continued from page 99)

short waves; the LxC column represents microhenries multiplied by micromicrofarads, for ease in figuring.

It will be seen that the large capacities used for broadcast tuning would demand inductances so small as to be impracticable, below 100 meters. For all-wave receivers, tuning capacities from .00014- to .000175-mf. (140 to 175 mmf.) have been popular; but for specialized short-wave receivers, the tendency has been to go lower yet. Even 32-mmf. midgets have been used successfully. It is true that, the smaller the capacity, the narrower the band covered; but the better results obtained, and the easier tuning in the band covered, are compensations.

The rule ("Nagaoka's") laid down in the textbooks for determining the inductance of a plain tubular or "solenoid" coil, expressed in familiar standards of measurement, may be thus simplified: first, multiply the square of the diameter of the coil, in inches, by the number of turns on the coil, and then by the number of turns to the inch.

The result is to be divided by a number which varies indirectly with the ratio between the diameter of the coil and its length. The inductance in microhenries is

about 1/40 of the product above obtained, for a coil very long in proportion to its diameter; about 1/200 of the product, for a coil of very few turns.

The number ("Div.") to be used for the division varies, as follows, for different proportions of the coil; "D/L" represents the diameter of the coil divided by the breadth of the winding.

TABLE II

D/L	"Div."	D/L	"Div."	D/L	"Div."	D/L	"Div."
8	100	3½	101	1½	71	8/8	61
7	155	3	93	1½	67	1/2	49
6	159	2½	89	1½	63	3/8	47
5	125	2½	85	1	58	1/4	44
4½	117	2½	81	7/8	55	1/8	42
4	109	2	76	3/4	53	Limit	40

Thus, for example, a coil is 2 inches in diameter and has a winding of 60 turns, in a space of an inch and a third. Then 2 x 2 x 60 x 45 (number of turns to the inch) divided by 67 (corresponding to the D/L ratio of 1½) equals 161 microhenries.

In the previous article, however, Mr. Denton gave a formula easier to memorize

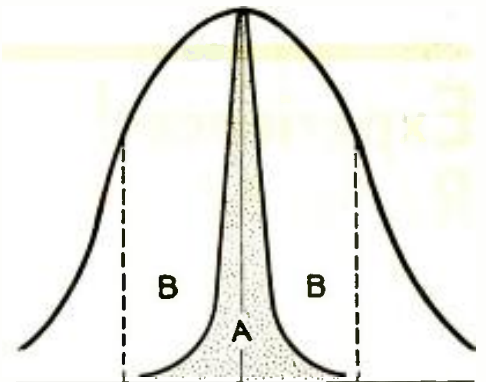

Inner curve shows Stenode's selectivity, outer curve that of ordinary receiver. Lines BB are 5 k. c. distant from Line A. All background noise included in the light portion between A and BB is eliminated by the Stenode.

## Data, Parts List and Blue Prints

Complete Schematic Diagrams and Construction Details for building:

## THE STENODE CIRCUIT

Price \$10.00

Developed under the patents of James A. Robinson, M.B.E., D.Sc., Ph.D., M.I.E.E., F. Inst. P., and former Chief of Wireless Research, British Royal Air Force, by the engineers of the Stenode Corporation of America.

No Stenode diagrams are genuine without approval and signature of—

*James Robinson*

Several reliable American manufacturers are now making all parts meeting Dr. Robinson's specifications for the Stenode circuit. The special quartz crystals—in tube form for convenient handling and mounting—are obtainable from us until the American Tube Manufacturers licensed by us are in sufficient production to supply the demand.

The Stenode Corporation of America now throws open to serious investigators the study of this revolutionary circuit, which is the greatest single advance since Morse invented the telegraph.

"If it isn't a STENODE it isn't a modern receiver."

**STENODE**  
CORP. OF AMERICA  
(Formerly American Radiostat Corp.)  
Hempstead Gardens, L. I., N. Y.

STENODE CORP. OF AMERICA  
Hempstead Gardens, L. I., N. Y.

Enclosed find  Personal Check,  P. O. or  Express Money Order for \$10.00 for which please send me complete diagrams, details and list of Parts for constructing the Stenode Circuit.

Name .....

Street .....

City ..... State .....



# Experienced Radio Men!

YOU Have had enough Experience in Radio to appreciate the need for **ENGINEERING TRAINING!**

Mail coupon for details **TODAY!**

**CAPITOL RADIO ENGINEERING INSTITUTE, INC.**

3166 Mt. Pleasant St., N. W., Washington, D. C.

Please send me, without obligation, your new illustrated booklet explaining your advanced course in Practical Radio Engineering.

Name \_\_\_\_\_

Address \_\_\_\_\_

Position \_\_\_\_\_ RC-8

**WORLD-WIDE SHORT WAVE RECEIVER**  
 ONLY \$6.45  
 Span the World with this Set!

A new radio thrill for you! Listen in DIRECT to London, Paris, Berlin, Buenos Aires and other broadcasting stations throughout the world via short waves. Enjoy unique foreign programs from strange lands. Your ordinary receiver cannot tune in these low wave stations. **WORLD-WIDE RECEIVER** gets 14 to 550 meter stations with surprising clarity. **SEND NO MONEY!** Just write your name and address on a postcard and ask us to send you this wonderful guaranteed short wave set. Pay postman \$6.45 plus a small delivery charge. All orders West of the Rockies must be accompanied by \$1.00 deposit. Price in foreign countries, \$7.75 delivered. Order today!

### NEW RADIO BARGAINS

- Low Power Transmitter adaptable for phone or code. With plug-in coils .....\$14.75
- B** Eliminator, Bone Dry with 280 tube, 180 volts, will operate up to ten tube set, fully guaranteed.. 6.75
- AC-A B C** Power Packs, completely assembled..... 8.75
- Tubes: UX type, 30-day replacement guarantee. No. 210, \$2.25; No. 250, \$2.45; No. 281, \$1.85; No. 245, \$1.25; No. 224, \$1.25; No. 227, 75c; No. 226, 65c; No. 171, 75c.
- International Microphone, two button for public address system and transmitters, speech or music.....\$9.75

**CHAS. HOODWIN CO.**

4240 Lincoln Ave., Dept. H-15, CHICAGO

**New! For AUTO Radio**  
 Types to Fit All Makes of Cars  
**LYNCH**  
 Spark Plug and Distributor Suppressors  
 Metalized Principle Insures Dependability and Long Life. Write for Illustrated Catalog CS  
 LYNCH MFG. CO., Inc., 1775 Broadway, N. Y. City

and which is of equal accuracy for practical purposes: divide, by 5, the square of the product of the diameter by the number of turns; then divide the result again by the sum of three times the diameter and nine times the breadth of the winding. The problem above works out at 160 microhenries, which is close enough.

### Effect of Coil Spacing

The first thing which is apparent on looking at these figures, is that the inductance, with the same number of turns and spacing, increases very nearly as the square of the diameter, if the coil form is not too long. A coil of twice the diameter, other things being equal, has four times the inductance, only twice the wire, and twice the ohmic resistance. However, short-wave coils have been getting smaller and smaller, just as have broadcast coils, for various reasons; including the need of complete shielding at a respectful distance from the coil itself.

As a matter of interest, it has been calculated that a coil, the diameter of which is equal to two-and-a-half times its length, is most efficient in the use of wire.

We also see that, with the same diameter and same spacing, a coil's inductance increases very nearly as its length; particularly as it becomes long and thin in shape.

Now, a short-wave coil requires very little wire, because its inductance is low. On the other hand, low capacity is more important at high frequencies. Instead of winding the wire closely together, as in a broadcast coil, we may space it without reaching an inconvenient size. Spreading a certain number of turns, if they are few, reduces the inductance comparatively little in a coil which is very narrow. Six turns on a 2-inch form, for instance, if they are wound at the rate of 30 turns to the inch, give an inductance of 3.7 microhenries; to be compared with 3.5 if they are wound at the rate of 24 to the inch. But, supposing that we use No. 22 wire in both cases, the spacing between the copper of the wires would be doubled, with considerable reduction in the self-capacity of the coil.

Instead of giving, therefore, the specifications of the coils with the wire, of different insulations, wound closely, we shall give them in turns to the inch.

It is customary, for ordinary purposes, to divide the short-wave band below 200 meters into four ranges, to be covered by as many sets of coils. This gives us, allowing a moderate overlap of the bands, a capacity ratio of about 4 to 1 over each band. It is impossible, of course, to specify the range which a short-wave coil will cover, without reference to the receiver in which it is placed; for very slight stray capacities have a much greater effect than in long-wave circuits.

(To be continued next month)

TABLE IV

ONE-INCH FORM: (Inductances in Microhenries)						
No. of Turns on Coil	Number of Turns of Wire Per Inch					
	7	11	17	25	33	50
3	0.26	0.32	0.38			
5	0.54	0.69	0.86			
7	0.85	1.13	1.42	1.72		
10	1.35	1.85	2.43	2.94	3.53	
15	2.12	3.11	4.0	6.4	6.2	7.6
20		4.4	6.2	7.5	9.5	11.8
25		5.8	8.3	10.8	12.8	16.6
30			10.2	13.9	16.6	21.6
40			14.8	19.6	24.4	31.8
50				25.5	31.8	43.4
60					31.25	39.8
75						61.6
100						102.0

THREE-QUARTERS INCH FORM:						
No. of Turns on Coil	Number of Turns of Wire Per Inch					
	7	11	17	25	33	50
3	0.14	0.18				
5	0.30	0.37	0.46			
7	0.48	0.64	0.80			
10	0.75	1.03	1.37	1.66		
15	1.24	1.76	2.24	3.04	3.5	
20		2.48	3.40	4.46	6.3	6.6
25		3.22	4.60	6.08	7.2	9.3
30			6.74	7.61	9.3	12.1
40			7.97	11.03	13.8	17.9
50				14.36	18.0	25.2
60					22.3	31.1
75						29.0
100						57.4

## The Latest Radio Appliances

(Continued from page 75)

otherwise, it is left unused.) The direct-current output of the filter is 300 volts, with taps at 220, 180, 135, 90, and 45 volts; the output is 125 milliamps, sufficient for push-pull pentodes. The rectifier is the standard '80, which is heated from an additional secondary. The pack thus contains all elements for a receiver or amplifier of ordinary heavy-duty requirements; its circuit is illustrated in Fig. 2.

(Manufacturer, Pilot Radio and Tube Corp.)

### MOTOR CAR RADIO SET

A N inexpensive automotive receiver, illustrated in Fig. E, is designed for ready installation; it operates from the car's storage battery and necessary dry-cell combinations for plate and grid voltages. As the schematic diagram (Fig. 4) shows, it

comprises three '24-type screen grid tubes two '27s, and a '45 output tube; in a very sensitive circuit. The control unit, at the left of the chassis, is fixed wherever it is most convenient; on the instrument panel, steering pillar, etc.

(Manufacturer, Charles Hoodwin Co.)

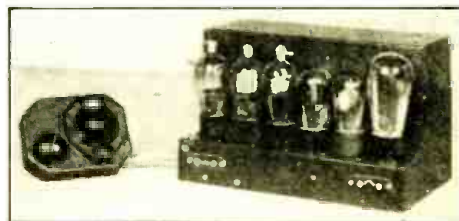

Fig. E

A readily-installed automotive set.

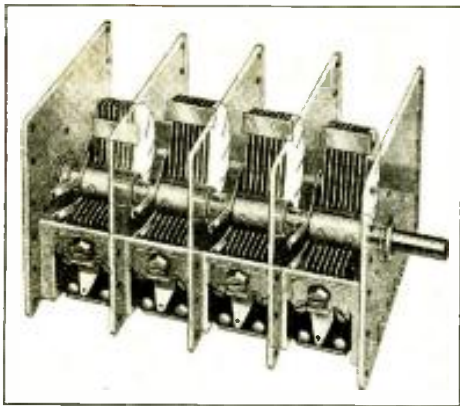

Fig. F

Note the smaller plates at the left.

**SUPERHETERODYNE TUNING GANG**

IN a new type of condenser gang, illustrated in Fig. F, the capacity variation of one set of plates differs from the rest. The purpose is that, in superheterodyne operation, an oscillator condenser tuning an inductance of 144 microhenries will preserve a resonance point removed just 175 kilocycles from the signal frequency, to which the other variable condensers tune 240-microhenry inductances. The frequency-changing circuit is thus simplified by the elimination of external "padding" condensers; and the number of adjustments needed in servicing is reduced. The instruments may be obtained in two-, three- and four-gang units, corresponding to one, two and three tuned circuits ahead of the I.F. amplifier. (Manufacturer, DeJur-Amsco Corporation.)

**RADIO FOR THE DEAF**

FOR those whose hearing is insensitive, or defective, a novel device (Fig. G) has

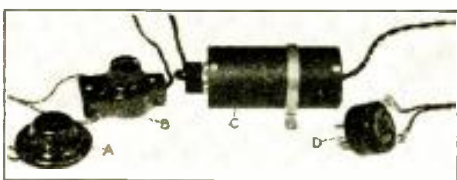

Fig. G

A, phone; B, volume control; C, coupling condenser; D, adapter, of the "Radio Deaf-Aid."

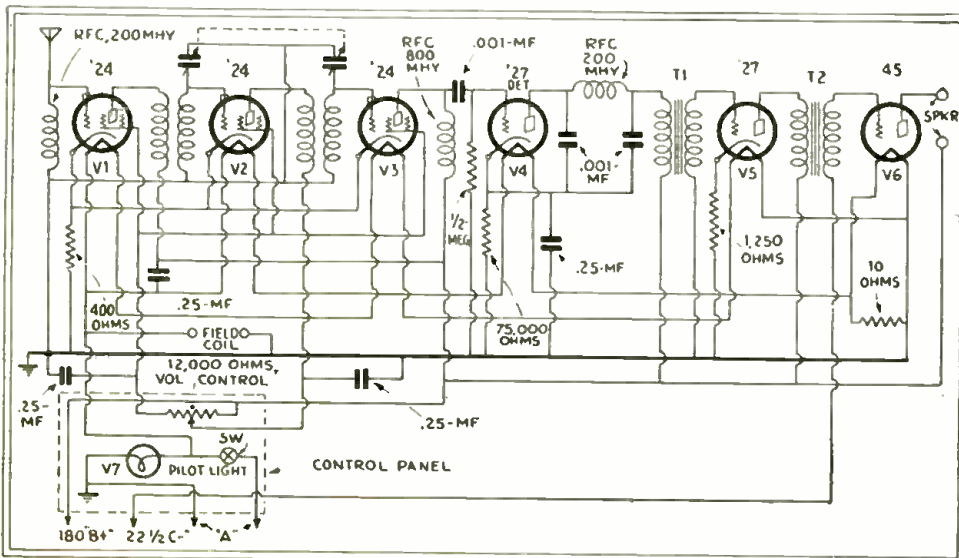

Fig. 4

Schematic circuit of the compact six-tube automotive receiver of Fig. E. It has high amplification and an output of large volume. Note series-parallel filaments.

been produced for use in connection with the output of a radio receiver. Reception on this device, which an adapter connects in parallel across an audio tube, has its own volume control, independent of the ordinary reproducer which may or may not be in operation at the same time. Fig. 3 shows the connections, and gives the constants of the device.

The small, light phone unit is of special design for the purpose; the equipment includes also an adapter and fixed condenser, together with the volume-control unit and extension cord. The device lends itself also to late-hour reception, when silence should be preserved in the home.

(Manufacturer, Sonotone Mfg. Co.)

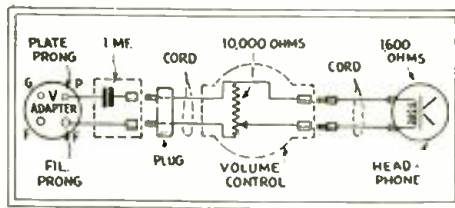

Fig. 3

Schematic circuit of the device for the hard-of-hearing, illustrated in Fig. G.

**NINE TO FIVE**

PRELIMINARY reports of the census of 1930, completed for twenty-five states and the District of Columbia, show that, on the average, there are nine homes without radio for five which are so equipped. In the District, however, there are six owners for every five without radio; while in the state of Mississippi, less than one home in eighteen has a set. The total for the country, at this rate, is about 11,500,000, a smaller number than previously estimated—but these figures, of course, do not include any of the midgets and other sets purchased since April 1, 1930, the date of the census.

**NEW DRY-CELL VALUE**

TO meet the conditions of tube operation in Europe, a large German manufacturer has produced a dry-cell with a voltage of 0.9, instead of the 1.5 hitherto standard. A battery with units based on this voltage would be convenient for many purposes; even in this country.

**SEE the artist  
you HEAR**



Look in on arrival of new radio art—**TELEVISION!** More stations are broadcasting better pictures for longer hours each month.

**JENKINS THE PIONEER**

Start right—with the ten years' experience behind Jenkins. It's yours through

**TELEVISION EQUIPMENT  
BY JENKINS**

**Receiver Kit**—ideal half-tone reception. Full A. C. operation. Complete parts, matched, ready to assemble and wire. \$69.50.

**Radiovisor Kit**—complete, machined, ready to assemble and wire. Ideal with Jenkins receiver. \$42.50; with lens, \$50.00.

**Ready-to-Use Models**—receivers and radiovisors, stripped or in walnut cabinets—up to \$350.00.

**ORDER NOW!** Be first to enjoy television in your territory. Use coupon below. Literature on request.

JENKINS TELEVISION CORP. (RC)  
Passaic, N. J.

Here is my order for  
 Radiovisor Kit  
 Television Receiver Kit  
 Check or M. O. attached  C.O.D.

Name .....

Address .....





**GET OUR LATEST CATALOG**

**2-Tube High Grade "HAM" Receiver Kit**  
\$20.00 Net

National AC 5 SW Short Wave Receiver  
Mershon Condensers

Send Ten Cents for Catalog  
CHICAGO RADIO APPARATUS CO.  
Established 1921 Dept. CF-8  
415 S. Dearborn St., Chicago, Ill.

**CLAROSTAT**

REPLACEMENT LINE BALLASTS AND VOLTAGE REGULATORS

When replacing voltage regulators install a real, long-lived, guaranteed CLAROSTAT LINE BALLAST and insure against voltage troubles. A better unit . . . for less money. Specified by leading set manufacturers. Write for list of receivers and the proper Ballast or Regulator required.

CLAROSTAT MFG. CO., Inc.  
285 N. 6th Street Brooklyn, N. Y.

**ALUMINUM BOX SHIELDS**

Genuine "ALCOA" stock, silverdip finish.  
5 x 9 x 6, \$1.89—14 x 6 x 6, \$3.85, 10 x 6 x 7 Monitor size \$3.25, 5 x 5 x 5 Coil Shield (like picture on right) \$1.00.  
Any Size to Order.



Pentode tubes—BALDWIN RIVAL UNIT (makes excellent mike) 95c. Make and break push buttons, 20c. Flexibio shafts for Auto Sets.

**"BUDDY" TEST PROD**

Always sharp pointed, using phonograph needles, 4-ft. wires, spade or phone tips. Colored nipples identify each lead, \$1.50 pair.  
We specialize in radio parts exclusively—parts furnished for any kit in any magazine. Please include Postage.



BLAN, THE RADIO MAN, Inc.  
89 Cortlandt St. Dept. RC-831 New York, N. Y.

**Study RADIO in CANADA**

CANADA'S PIONEER COLLEGE, endorsed by leading radio manufacturers, offers DAY, EVENING, HOME STUDY and SPECIAL TRADE COURSES with free scholarships and trip to Toronto (all expenses paid). Write for booklet to Principal.

RADIO COLLEGE OF CANADA Limited  
310 Yonge Street - - - Toronto

**PUBLIC ADDRESS EQUIPMENT**



MILES REPRODUCER CO  
26 E. 22<sup>nd</sup> ST. NEW YORK CITY

**PATENTS**

Write for Free Guide Book, "HOW TO OBTAIN A PATENT" and Record of Invention Blank. Send model or sketch and description of your invention for our Free Opinion whether it comes within Patent Office Rules. RADIO and ELECTRICAL Cases a Specialty. Prompt Efficient Service. PAYMENT OF FEES IN INSTALLMENTS  
VICTOR J. EVANS & CO., 923 - 9th, Washington, D. C.

**Pentodes and Their Use**

(Continued from page 97)

**Pentode Direct-Coupled Amplifiers**

Much interest attaches to the high gain theoretically obtainable in well-designed "direct-coupled" amplifiers; in which the plate of one tube is directly connected to the control-grid of the following tube.

The writer believes that the diagram shown in Fig. 2 is the first to appear in print, specifying the new pentode tube for the power audio stage in a direct-coupled amplifier.

Note the specifications as to power requirements; amplifier design lends itself very well to use in conjunction with a microphone or a phonograph pick-up, in addition to its adaptability to the requirements of the audio (or audio and detector) end of standard radio receivers.

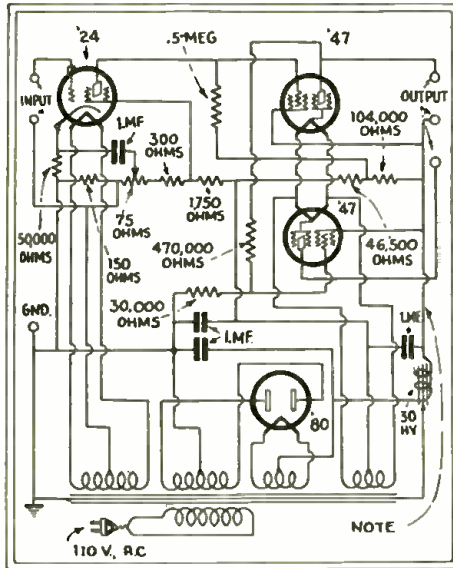

Fig. 3

Design of a five-watt amplifier using two A.C. pentodes in a very interesting circuit. Drawn, 80 ma. at 435 volts.

All electrical values are given in the diagram. It is presumed that the constructor will use conveniently available instruments; since no make or model numbers are specified in this engineering circuit.

**Push-Pull Pentodes**

Push-pull operation continues to interest not only the engineer, who is familiar with its principle, but also the customer, who recognizes its effect. Manufacturers are responsive to the opportunity; Crosley, Clarion, Fada, Bosch, Apex, Lyric and

Brunswick have announced push-pull pentodes in their latest models.

The writer, therefore, takes pleasure in presenting to the fraternity of constructors what is, probably, the first published diagram of a direct-coupled audio amplifier, using American standard pentodes in push-pull, and serviceable wherever a 5-watt power amplifier of exceptionally fine frequency characteristics is required. (Fig. 3.)

The method of obtaining the phase shift is exceptionally interesting; since the voltage gain of the pentode is 14.7 (approx.) per stage. A tapped resistor, or two resistors in series, connected between plate and the ground or "B—", are of such value that the voltage appearing between the ground and the connection to the opposite tube grid is equal to 1/15th the voltage between the plate and ground. (These resistors must have high resistance values, so that no appreciable direct current flows through them.)

The output is conventional.

(In the next issue of RADIO-CRAFT, Mr. Denton will give additional information about the pentodes, and the characteristics which distinguish their performance, when used in audio amplifiers.—Editor.)

**The Open Forum**

(Continued from page 83)

happen to be situated, we Service Men pull together and never try to put anything over on the next fellow. We even go so far as to help him out with a part which he may need and cannot get quickly; thus saving him the annoyance of delay. I certainly am glad I am not in Fremont, Nebraska. However, I have the consolation that the only reason a man may be loth to give any information to the next fellow is that he has none to give, and depends on the information he gets from the other fellow to do his own servicing.

It is common knowledge that engineers of national reputation are always willing to give information of help to any one who may need it.

In closing I want to express my wishes to the continued success of RADIO-CRAFT and thanks to the men who help to keep it a success.

J. P. MAZZA,

68 Silver Avenue, Hillside, N. J.

(We admit the first impeachment: this

The interested reader may consult these articles: "A Bureau of Standards Audio Amplifier," Sept., '29; "Constructing the Loftin-White Amplifier," Sept., '30; "How to Build a Direct-Coupled '45 Amplifier," Dec., '30; diagrams of commercial receivers incorporating direct-coupled amplifier circuits, on page 407, Jan., '31; and the official "Electrad Loftin-White" direct-coupled amplifier circuit on page 25 (and the companion R.F. chassis, on page 40), of the July, '31 number of RADIO-CRAFT.

For the theory on push-pull circuits, see the series of four articles by Edgar Messing in the December, 1930, January, 1931, March and May issues of this magazine.

A direct-coupled push-pull pentode amplifier was described in the August, 1930 issue of RADIO-CRAFT (page 100); but this was designed for tubes which are not available in the United States.—Technical Editor.

**New! A NON CORROSIVE QUICK ACTING SOLDERING FLUID**

ZYLENE, Used in leading laboratories. A perfect solvent for carbon and allied metallic oxides. All traces of flux non-toxically eliminated. Prevents "Rosin Joints". Acid Free. Unsurpassed for short wave, and all low loss circuits. Rapid, efficient. Easy to use. Guaranteed.

**BIG BARGAIN SPECIALS!**  
Flexible Multi-Stranded Drum Dial Cable, 25 ft., 59c; 50 ft., 87c; 100 ft., \$1.69. Majestic, R.C.A. Cables 17c; 6 for \$1.00. Wiring Diagrams, for any set 35c. Send check, money order or stamps.

**RADIO MERCHANDISOR**  
315 E. 96th St. Brooklyn, N. Y.

**FREE REFUSE**

error was corrected in subsequent issues. The diagram of the tube checker carried all the values on the manufacturer's blueprint; others, undoubtedly, were calibrated to the individual instrument in a testing laboratory. With reference to the oscillator, if Mr Mazza will apply a little arithmetic, he will find that the value of 6.2 millihenries is required, with a .0005-mf condenser, to tune from 1,200 to 3,333 meters—90 to 250 kilocycles. The LxC product—see page 55 of the same issue—is 3.129 for the lowest frequency. As to the policy of cooperation among the Service Men in a neighborhood which he describes, it cannot be commended too highly.—*Editor.*)

**MORE ABOUT THAT TESTER**

By Vincent T. Campbell

**I**N regard to the "Simple Tube Tester" which I described in the March issue, and

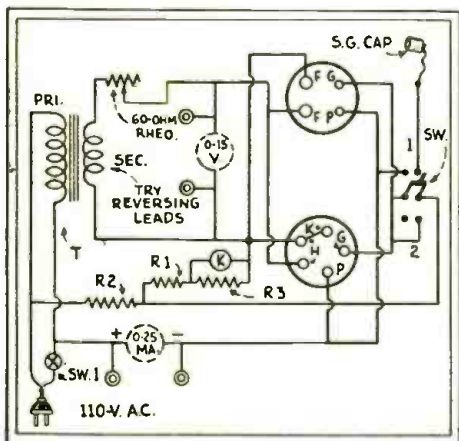

Latest version of the Campbell tube tester.

which has caused some discussion, permit me to make a few remarks:

Instead of the 9½-volt transformer first suggested, I am now using the 5½-volt winding of a Pilot transformer from a "Universal 'B'" eliminator; this will supply current for all tubes except a '10, a '50 or an '81. I think that it might be possible to get a comparative reading, even on a tube of these types, which would give a fair test; however, I do not make any such assertion positively, as yet.

Secondly, to obtain almost perfect regulation, I use a 60-ohm rheostat; I know this to be suitable, and it will save one control, when compared with Mr. Sanguinetti's method, explained in the June issue.

Again, let me specify the use of a power switch in the A. C. line, for two reasons. First, as a matter of safety in case of blowing out the tube under test, because we will, surely, some time forget to set the rheostat at full resistance. Second, it is more convenient to have a switch than to go down, often, on hands and knees to search for an A. C. receptacle.

I wish to thank Mr. Sanguinetti for his valuable reminder as regards the correct polarity of the filament. This is important; but it is easily arranged by reversing the leads, as he says.

I have combined the tester, as above described, with two other meters in a convenient circuit, making all the scales involved available. It is housed in a metal tool box (Utileco), cost only \$18 and is a jim-dandy.

(More interest has been aroused in this tester than in any other piece of service apparatus we have described. This has been heightened by the difficulty the artist has found in making the proper connections to the switch. The corrected diagram is reproduced here.—*Editor.*)

**Radio Typewriter**

(Continued from page 74)

ing the ring of commutator segments; and the next dot which comes will print the letter corresponding to whatever segment the contact arm is resting on at the instant. It is obvious, of course, that the two commutators, at transmitter and receiver, must rotate in exact step; and that the signal must be sharp and clear. A burst of static may literally "punctuate" any sentence; but the receiver may be very selective, in both R.F. and A.F. channels.

The idea, however, lends itself to secret, or at least code communication. The order of letters on the commutator may readily

be changed, according to a preconceived plan; so that a "letter-transposition" cipher would result, on a machine not corresponding arranged. While this can be read easily by a cryptographer who has time to work on it, a further change in the synchronizing speed would make the message a little more elusive for any "reader-in" who tried to tap the communications.

For clearness in the details, only four of the commutator segments are shown in each diagram; the number, however, may be adjusted to the number of characters which it is desired to reproduce.

A circuit, used for the oscillator at the transmitting station, is shown in Fig. 3, with some of its constants; others depending, of course, upon the frequency which it is desired to reproduce. The receiver may be of the usual type for short-wave reception; it can employ regeneration effectively.

Demonstrations were recently given by Mr. Watson and his associate, Fred Wardell, to the newspapers of Detroit and representatives of the federal and state governments, of the practical operation of the "Watsongraph" which, its inventor believes, is especially suited to official intercommunications of a police nature, etc.

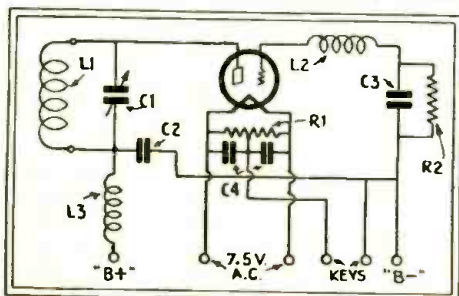
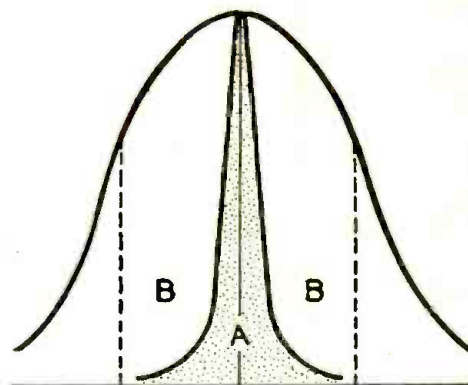

Fig. 3

Oscillator used to transmit the typewriter signals: C1, .0005-mf.; C2, .002; C3, .00025; R1, 50 ohms; R2, 10,000 ohms. L1, "tank" inductance, L3, R.F. choke.



Inner curve shows Stenode's selectivity, outer curve that of ordinary receiver. Lines BB are 5 k. c. distant from Line A. All background noise included in the light portion between A and BB is eliminated by the Stenode.

**Stenode Tubes**

Until the American Tube Manufacturers licensed by the Stenode Corporation of America are in sufficient production, we can supply the rapidly growing demand of laboratories and serious investigators for:

**QUARTZ CRYSTALS**

Suitably Mounted in Tube Form To Fit Standard Tube Sockets

These crystals are all approved by our own laboratory after actual tests in a standard Stenode developed under the patents of Dr. James A. Robinson, M.B.E., D.Sc., Ph.D., M.I.E.E., F. Inst. P., and former Chief of Wireless Research, British Royal Air Force, by the engineers of the Stenode Corporation of America.

All crystals are ground to respond to a frequency of 175 kilocycles, which is the frequency accepted as standard in all modern superheterodynes, and are mounted in vacuum tube form.

**STENODE TUBES** (Standard UX Socket Base) Price \$15

Demand for Stenode Tubes is creating imitators. None is genuine without this signature.

*James Robinson*

"If it isn't a STENODE it isn't a modern receiver."

**STENODE CORP. OF AMERICA**  
(Formerly American Radiostat Corp.)  
Hempstead Gardens, L. I., N. Y.

STENODE CORP. OF AMERICA  
Hempstead Gardens, L. I., N. Y.  
Enclosed find  Personal Check,  P. O. or  Express Money Order for which please forward me.....Stenode Tubes.  
(state number)

Name.....  
Street.....  
City.....State.....





# The key to every radio problem



2,201 Definitions  
1,253 Illustrations

352 pages.  
Size 9" x 12"  
Flexible Red Morocco-Keratol Gold-Stamped Cover.

## A SYMPOSIUM OF INFORMATION TOPICALLY ARRANGED IN ALPHABETICAL ORDER

This book is not a dictionary, but a true Radio Encyclopedia, covering Radio from A to Z.

It is a large book of 352 pages, 9 inches wide by 12 inches high, and weighs three pounds. There are 2,201 radio definitions, A B C indexed like any dictionary, making every bit of radio information you want "findable"; 1,253 detailed technical

illustrations; 34 tables and charts; 24 pages of Appendix, etc. The binding is flexible red morocco-keratol, with title gold-stamped on cover and backbone. The text is printed on durable, fine ledger paper, and the loose-leaf construction permits of new material being added, such as notes, addenda data, etc.

### WHAT THE NEW SECOND EDITION RADIO ENCYCLOPEDIA GIVES YOU

It gives you an explanation of every word used in radio. These explanations—or, rather, definitions—are not brief outline information like those of an ordinary dictionary, but they give in fullest detail, and at considerable length, the meaning and application of every word, phrase, general and special term used in the science of radio. They are written in plain, everyday English, easily understood by anyone.

Practically every definition in the book is illustrated by drawings, photographs, diagrams, or charts. All you need to do is to look up the word or phrase

about which you are in doubt, under its proper heading. ALL THE SUBJECT MATTER IS ARRANGED IN ALPHABETICAL ORDER.

Numerous tables, charts, and maps are distributed throughout the text. A large section of the Appendix contains information of commercial value, such as lists of all radio receivers, their manufacturers, trade names, tubes used, styles, etc. There are charts of tube-socket lay-outs of all makes of sets; broadcast stations listed by wave-lengths, call letters, towns and states, etc.

### ABSOLUTE GUARANTEE

If the book does not come up to your expectation, or is not as represented, or if you do not want it, for any reason whatsoever, you can return it and

have your money refunded, without question. Use the order blank below for convenience in ordering, and mail it to S. Gernsback Corporation.

S. GERNSBACK CORPORATION  
98 Park Place, New York, N. Y.

Kindly send me one copy of the new Second Edition S. Gernsback Radio Encyclopedia. I will pay postman \$3.98 plus a few cents extra for carrying charges. (Foreign and Canada must remit with order, add 35c. extra for postage). If the book does not come up to my expectations, or is not as represented, I can return it, and have my money refunded in full.

Name .....  
Address .....  
City ..... State.....

### SEND NO MONEY

Just fill in coupon at left and mail it TODAY.

We want you to be satisfied—keep it or return it—you have the option.

## Service Men's Testing Equipment

(Continued from page 86)

sets as a choke. Any type of speaker can be tested on the bench, and compared with the speaker mounted in the hench, by throwing switches. The bench also has an outlet from the phonograph to plug into sets on test.

While a set is using the speaker in the bench, another speaker can be put on the bench for test. The amplifier can then be turned on, with phonograph attached; and the set can use either speaker, or be switched to the amplifier and either speaker used, without touching an outside wire.

The apparatus includes a thermogalvanometer, ammeter, milliammeters, ohmmeter, microfarad meter, A. C. and D. C. meters.

The bench is finished in dark green duco; the panel is of ivory formica, with chromium hardware. The flat top is covered with "battleship" linoleum. The bench is 74 inches long and 31 inches deep; the test panel rises 66 inches. Two months was required to complete its construction.

## Hints to Manufacturers

(Continued from page 87)

### FOR EASIER REPLACEMENTS

SINCE small bypass condensers frequently short, I suggest that manufacturers bolt them to the chassis, rather than brad them down. This will help quite a lot when the occasion for replacing them arises.

M. EDOUARD DE BEAUCHAMP,  
228½ No. 15th St., Muskogee, Okla.

### REMOVABLE CHASSES

I WOULD like to suggest that manufacturers fasten chasses so that they will be easy to remove from the cabinet. Most sets are fastened with enough bolts to hold an auto together. The Sparton "930" has a very nice method, and I recommend other manufacturers to take a look at it.

FREDERICK E. BARBER,  
506 Tyson Place, Syracuse, N. Y.

### OR "TRANSPORTABLE" SETS

SOME kind of roller, or slider, under the legs of console models, would make the cabinets much easier to move without damaging floors, and also help to protect the receiver itself.

RUSSELL LEACH,  
Glen Rose, Texas

## Short-Wave Converters

(Continued from page 93)

frequency amplification, a first oscillator, and a first detector (or modulator), all in the converter, followed by; one stage of first intermediate frequency amplification (formerly the broadcast R.F. stage), second oscillator, second detector, second intermediate frequency amplification, third detector, first or power audio, all in the broadcast set. This may sound formidable, but all follow in natural sequence.

Converters will not work so well with supers, unless there is, in the broadcast set, some amplification ahead of the first detector to successfully transfer the converter beat signal. With a stage of amplification following the converter's output, the beat-frequency produced by the converter may be amplified at 1500 kc. The oscillator and modulator in the super will again change this to the lower frequency to which the intermediates in the super are adjusted.

Two main methods of changing the tuning band are used in converters. One calls for a coil tap-switch, and the other, for plug-in coils. In the switching system, the connection between the lever and contacts must be perfect. The introduction of resistance, through a faulty contact, may cause either lack of oscillation, broad tuning, or lack of sensitivity.

Where the plug-in coil system is in use, the contacts of the pins and jacks must be kept clean.

**Selective Circuit Design**

Although, when the converter is operating correctly, broadcast signals should not be heard, at times strong signals may be

picked up inductively by the wiring or components and reproduced. To avoid this, the converter's output may be tuned in the very simple manner shown in Fig. 1.

A tube 1 1/4 inches in diameter is used. First, 80 turns of No. 28 enameled wire are wound for coil L5. About 1/8-in. space is left, and thirty turns of No. 28 wire are then wound for coil L6, tapping it at the 10th and 20th turns. A .0002-mf. Hammarlund "midget" condenser with "midline" frequency variation, fits the tuning job very well. The device will work best when placed in a shield can; since all possibility of broadcast pick-up will then be eliminated. This case must be at least two inches from the coil unit at every point.

The ground may be used when the converter is of either the battery type, or the AC type using only a filament supply. If the converter contains its own "B" supply (Fig. 2) the extra ground is not necessary; since one side of the line is grounded. Consequently, if the line plug is wrongly inserted in the 110-volt outlet receptacle, a faint hum will be heard; in which case, it is best to leave the set's ground unconnected.

(To be continued in September RADIO-CRAFT)

# The Short-Wave Superregenode

(Continued from page 93)

broaden slightly the tuning of our acceptor-trap, a 5,000- to 10,000-ohm variable resistor R (Fig. 11) may also be connected in series at X and adjusted for best effect.

The thrill of working great distances is not a new one for the short-wave fan; but obtaining this result at excellent loud-speaker volume, with low current consumption and extreme circuit simplicity, is something further. The beauty of the design is that much may be learned through working with it; extraordinary loud-speaker results may be gained; and in the A.C. model, the Superregenode does not present the complications that exist in even the ordinary regenerative short-wave A.C. receiver.

**Variations and Applications**

Countless ideas can be developed by the fellow with a little inventive ability and the initiative to push them through. For instance, there is before us the use of variable-mu tubes in place of the more standard screen-grid type. Again, it is possible to modulate the screen-grid circuit with the output of a microphone amplifier and "mike"; when you will have a low-power speech transmitter!

Indeed, by suitable switching arrangement and parts selection it is possible to build up a portable combination transmitter and receiver with very great range for the tubes used and power expended; something in the order of 5 miles as a transmitter, and thousands as a receiver.

Instead of speech transmission, code may be sent by breaking with a key the detector circuit when adjusted for oscillation. The local oscillator, instead, may be keyed, if desired; and thus modulation of the oscillating detector's output signal may be obtained and varied by adjustment of the local oscillator.

Acknowledgement is here made of the

courtesy of York Engineering Service for the use of their equipment and laboratory facilities for the construction and testing of this interesting receiver.

If any of the readers of RADIO-CRAFT wish to write to obtain any assistance in the construction of the Superregenode, the writer will be glad to oblige if a stamped and return-addressed envelope is enclosed with the inquiries. It is hoped that constructors will not deviate too greatly from the parts recommended and constructional data just completed, in their choice of apparatus, and the individual arrangement of the chassis. Nevertheless the ramifications of the Superregenode are legion, and the writer expects to receive some mighty interesting comments on the results obtained by some of the more advanced technicians.

**List of Parts—Battery Model**

- Two Hammarlund "MLW-125" 125 mmf. Short Wave condensers, C1, C2, and two Kurz-Kasch vernier dials;
- One Hammarlund 14-to-110 meter "Model LWT-4" short-wave kit, L1;
- One Hammarlund 14-to-110 meter "Model LWC1" short-wave kit, L2;
- One Hammarlund "Type RFC 250" 250-nh. R.F. choke, RFC1;
- One Hammarlund "Type EC 80" 80 mmf. equalizing condenser, C4;
- One Flechtheim filter block (five 1-mf. units), C6, C7 (2 mf.), C8 (1 mf.);
- One Ferranti "Type AF-5," 3.75-to-1 ratio audio transformer, T;
- Two Sangamo .001-mf. fixed condensers, C3, C5;
- Two Electrad 50,000-ohm "Super-Tonatrols," R1, R2;
- One Acme 30-kc. I.F. transformer, L3 (see text);
- One Yaxley 7-wire cable, 3 to 9;

(Continued on page 116)

## Make Depression Pay!

Take advantage of the present demand for repair of old receivers! Build strongly for the future, and increase your business by giving GUARANTEED REPAIRS.

You can do this safely by using Radio's Finest Parts—

## POLYMET PRODUCTS

Standard of the Industry

FOR FILTER BLOCK REPAIRS THE POLYMET KIT of 25 UNCASED CONDENSER SECTIONS illustrated below—is the most useful Kit ever assembled for service work. Many capacities and sizes, all in strict accordance with R.M.A. ratings.

Mail the Coupon for special low-price introductory offer. It will also bring you the new 1931 Polymet Parts Catalog, containing many service helps.

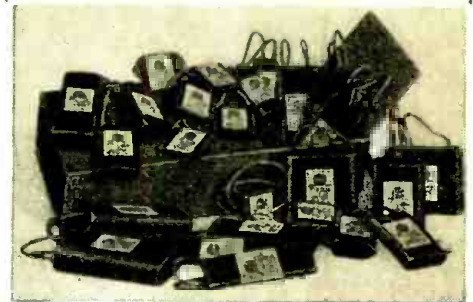

**POLYMET MFG. CORP.**  
829 East 134th St.  
New York City.

Send me your sensationally low-priced introductory offer on the Polymet Condenser Repair Kit. Also include the new 1931 Polymet Radio Parts Catalog, without charge.

Name \_\_\_\_\_  
Address \_\_\_\_\_  
City \_\_\_\_\_  
State \_\_\_\_\_

Mark Proper Square  
 JOBBER       DEALER  
 SERVICE MAN     CUSTOM SET BUILDER

## AUTO RADIO

**Long Distance Receiver**

**Amazing Low Price!**  
**Quality Performance**

Six tube triple screen-grid using 3-224, 2-227, and 1-245 power tube. Easy to install. Will fit any car. Single dial control. We guarantee that this set will pull in stations within a radius of 1,000 miles and that it will deliver the volume and tone qualities of an electric set, or your money refunded.

**PRICE OF SET ONLY \$20.00**

Price Complete, including tubes, batteries, dynamic speaker and suppressors, all ready to install and use, \$39.50. Send \$5.00 deposit with order, balance C. O. D. On foreign orders remittance in full required. **ORDER TODAY.**

**CHAS. HOODWIN CO.**  
4240 Lincoln Avenue, Dept. H-150, Chicago, Illinois



# The Two Latest Books on RADIO SERVICING

## Official Radio Service Manual

and Complete Directory of All Commercial Wiring Diagrams

Edited by HUGO GERNSBACK



\$3.50  
A Copy

THE OFFICIAL RADIO SERVICE MANUAL is the greatest achievement ever attempted in the Radio Service Field. It is not only the OFFICIAL RADIO SERVICE MANUAL and Complete Directory of all Commercial Wiring Diagrams, but it contains a complete and comprehensive course of instruction for radio service men. Just off the press and more than 27,000 copies sold. And why not, when it fills such a universal need among Manufacturers, Jobbers, Dealers, Service Men and all interested in radio? The OFFICIAL RADIO SERVICE MANUAL is complete and gives you every circuit of every set manufactured of which there is any information. Its looseleaf and flexible leatherette covers enable additional servicing data to be added periodically. There are hundreds of time-saving kinks which will help to increase your business and profits.

As the NEW YORK SUN says, "It is difficult to see how any service man can conduct his business satisfactorily and efficiently without this 350-page volume."

Over 1,000 Diagrams and Illustrations — 352 Pages

## Radio Service Man's Handybook

With Addenda Data Sheets

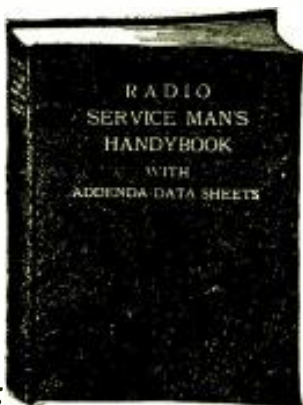

THE RADIO SERVICE MAN'S HANDYBOOK contains a tremendous amount of authentic material and practical information on Modernizing old receivers; Servicing obsolete sets; Repairing power packs; Construction of test laboratory equipment; Vacuum tubes; Set testing with analysers and hundreds of other similar subjects. Among the contributors are Bertram M. Freed, Leon L. Adelman, Paul L. Welker, Sylvan Harris, C. W. Palmer and others.

The HANDYBOOK enables service men to record notes, diagrams and charts on the special 48-page section of specially ruled sheets included in the book. Over 200 pages in all—size 9 x 12 inches.

\$2.00 Hundreds of Diagrams, 200 Pages, 9 x 12 inches

**BOTH BOOKS  
for \$5.00**

**MAIL COUPON  
TODAY!**

GERNSBACK PUBLICATIONS, Inc.  
96-98 Park Place, New York, N. Y.

RC-8

I enclose herewith check or money order for \$..... for which you are to send to me postage prepaid the  
 Official Radio Service Manual..... \$3.50  
 Radio Service Man's Handybook..... 2.00  
**OR BOTH BOOKS FOR \$5.00.**

Name .....  
 Address .....  
 City .....  
 State .....

Two Eby lettered binding posts, 1 and 2;  
 One output connection block, 10-11;  
 Two Pilot 4-prong UX sockets, V1, V2;  
 One Pilot 5-prong UY socket, V3;  
 One aluminum cabinet 7 x 9 x 18 x 3/32-in. thick;

Two aluminum sheets (partitions), 7 7/8 x 9 5/8 x 3/32 in. thick;

Miscellaneous hardware (screws, nuts, lock-washers, wire, etc.).

The kit of coils designated as LWC1 consists of single windings with the same number of turns as the secondary in the Type LWT4 kit. Data on the latter are as follows:

Meter Range	Sec. Turns
14- 24.....	3
22- 40.....	7
36- 65.....	15
60-110.....	24

The first two coils are wound with No. 16 D.S.C. wire, 11 turns to the inch; the last two coils, No. 18 D.S.C., 17 turns to the inch; all on forms two inches in diameter. The adjustable antenna primary has 6 turns of No. 28 D.S.C. wire on a two-inch tube.

## Remote Control

(Continued from page 79)

on the R.F. tubes. The complete attenuator circuit is shown in Fig. 11.

It should be noted that this arrangement makes possible the use of four different inputs. In the New Yorker, only two are available; but there is an additional amplifying channel through which a third program may be handled. The relationship of the two systems is shown by diagram in Fig. 12.

In the interconnection between two or more circuits, where there are attenuators, it is required that the impedance of both circuits shall remain constant when the attenuators are varied. The reason for this is that the greatest amount of energy is transferred only when a resonant or perfect

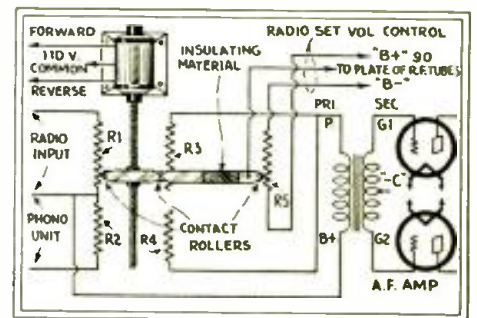

Fig. 14

The remote-control, motor-driven attenuator: R5 is connected at a suitable point in the R.F. tuning unit.

matching condition is approximated. Line transformers may be perfectly matched with one another but, if the volume control, inserted in the line between the transformers, does not uphold the impedance value (but instead varies the impedance with the attenuation) then the frequency output is very poor. A "constant impedance" control raises or lowers the energy level between two circuits without affecting the impedance.

Of several types of constant-impedance controls, three are shown in Fig. 13. The





# Hotel Directory of the Radio Trade

The hotels on this and opposite page are patronized by the Radio Trade. Make them your headquarters.



## HOTEL CONTINENTAL

Conveniently located just across from the Union Station Plaza  
**ALL OUTSIDE ROOMS**  
*Excellent Food*  
**DINING ROOM & COFFEE SHOP**

**C. J. COOK**  
*Manager*

**RATES**  
 WITHOUT BATH  
 \$2.00 to \$2.50 single  
 \$3.00 to \$3.50 double  
 WITH BATH  
 \$2.50 to \$5.00 single  
 \$4.00 to \$7.00 double

**GARAGE**  
 IN CONNECTION

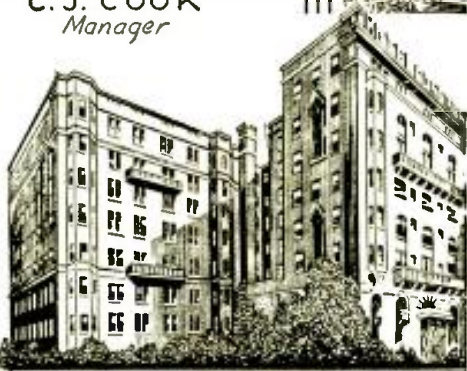

**WASHINGTON D.C.**



## Chicago's Favorite Hotel

The most experienced travelers select the BISMARCK as Chicago's outstanding hotel. Right in the heart of all business, social and civic points of interest. An ultra-modern building equipped with every comfort-contributing luxury. Famous for its cuisine and excellence of service. All dining rooms and coffee shop are artificially cooled. Write for booklet with downtown map.

Rooms, \$2.50 up—With Bath, \$3.50 up

**NEW**  
**BISMARCK**  
 HOTEL CHICAGO  
 RANDOLPH AT LASALLE

## The Home Hotel of New York

Homelike in service, appointments and location... away from noise and congestion, yet but a few minutes from Times Square... garage facilities for tourists.

Room and Bath from  
 \$3 single \$4 double  
 500 Rooms

Home folks will like this hotel

**HOTEL**  
**BRETTON HALL**  
 BROADWAY at 86th ST.  
**NEW YORK**

A SPECIAL OFFER TO NEW READERS  
 — Eight months subscription to RADIO-CRAFT for \$1.00. Send remittance to RADIO-CRAFT, 98 Park Place, New York, N. Y.

more expensive (though some manufacturers sell it for less than the "H") and, also, the "H" type can be constructed from ordinary potentiometers, the former is not as common as the latter.

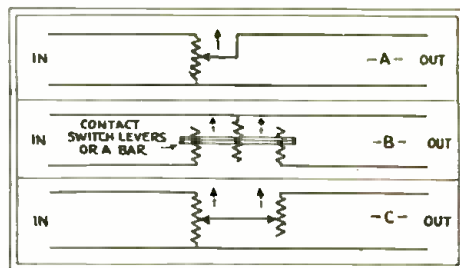

**Fig. 13**  
 The simplest attenuator, the "L" type, is shown at A; the "T" type at B; and the "H" type, which is more common at C.

## Recording Equipment

(Continued from page 81)

### New Best Apparatus

The Best Manufacturing Co's. recording apparatus, shown in Fig. D, is very similar to the "Recordovox" except for the method of weighting the recording head, which is very ingenious. No external weights are added to the recording head. When the unit is to be used for recording, the lever L is pushed over to the side marked "R," locking the recording head and preventing it from swinging about a joint A. For reproduction, the lever is moved to position "P," and motion takes place at joints A and B. The balance of the recording head is such that, when its weight is fully applied to the record, it exerts enough pressure to make a good recording. This novel method of increasing the effective weight of the head possesses an advantage in that no weights are required; at the same time, it has the disadvantage that, should the turntable motor develop insufficient torque to pull the record at a constant speed, because of the great weight of the head, a poor recording will result. Under this condition, the lever is dispensed with, and weights are substituted to mount on top of the recording head. The method of installation and operation are the same as described for the Paent unit.

### Late Model Ungrooved-Disc Recorder

In Fig. E is shown the newest development in the way of home recording equipment, of Presto Machine Products, Inc. In this one kit are contained all the mechanical units (cutting head, feed-screw, worm, worm gear, etc.) necessary for recording on blank ungrooved discs. This entire mechanism is so constructed that it can easily be lifted from the turntable, for changing records, by simply pulling upward a handle, H.

Installation is very simple. The only requirement is to fasten the plate to the motor-board, first making sure that the clamp-worm CW will couple easily to the spindle of the turntable when the handle H is brought down. The clamp comprises a double-thread worm that is driven by the spindle of the turntable. This worm meshes with a pinion gear (PG, Fig. F) mounted at one end of the feed-screw shaft FS. This screw has 12 threads to the inch;

the threads being of the "buttress" type. Since the ratio between the worm and pinion gears is 8:1, and the feed-screw has 12 threads to the inch, the number of lines per inch that will be cut into the record will be 96.

The cutting head is weighted with a 3-pound weight, W, the bottom of which is recessed and lined with leather at V, so that it will mesh in noiseless and proper manner with the buttress thread of the feed-screw.

The Presto recorder is supplied in kit form; and contains, besides the cutting unit, a control box, microphone, microphone pre-amplifier, using a type '27 tube, pick-up and turntable. The operation of the control box (not shown here, but illustrated in the June issue) is similar to the above-mentioned control boxes, except that when the knob is turned to "Phono," the phonograph pick-up is cut into the circuit.

The cutting mechanism can be used with either the Pacent "Recordovox" or the Best control box, by simply inserting the recording head leads into the receptacles marked "Phono." It must be borne in mind that this unit is not suitable for the playback; and, when the latter connection is desired, it is necessary to remove the recorder leads and substitute pick-up leads.

This about completes the description of the home recording equipment now on the market. There are many other phases, of this fascinating and rapidly growing offspring of the radio and phonograph arts, which so far have not received the attention of any books or magazines. In due time, the writer will consider each of them in their proper sequence. Meanwhile, if there are any questions in the minds of readers of this department (A huge stack of mail attests that there are—varied and numerous.—*Tech. Ed.*), answers to them may be obtained by writing, enclosing a stamped return envelope, to the attention of the Sound Recording Department of RADIO-CRAFT.

### Fifty-Watt Amplifier

(Continued from page 97)

former PT2 for the plate supply, and also makes it possible to use much smaller condensers without danger of breakdown due to voltage surges. This design is desirable when mercury-vapor rectifiers are used.

#### Operating Data

The operation of the amplifier is not different from that of the usual low-power push-pull stage; but it is necessary that the tubes be balanced, if long life is to be expected. The split secondary of the input transformer T3 contains a 400-ohm potentiometer R13 for this purpose; it should be so adjusted that the plate-current swing during operation is the same in each tube. Loss of emission in one tube or softening of the tube may be readily indicated by use of the two meters M1 and M2 in the jacks J1-J2, J3-J4, which should be mounted on the panel.

It is essential that the full filament voltage be applied to the rectifier tubes V7, V8 if they are to have long life; lowering the filament voltage increases the internal

## Hotel Directory of the Radio Trade

### HOTEL CUMBERLAND

54th Street and Broadway

New York City

3 Minutes to Times Square

*Close to Everywhere—but Removed  
from the Noise and Clamor*

A modern fireproof hotel with every modern hotel convenience. Within walking distance of theatres, shops and business sections.

**DAILY RATES: Room and Bath, \$2 and \$3 per day**

Special Weekly Rates

Under the Personal Management of Joseph Goulet

formerly of Hotel Woodstock, New York City

FREE CATALOG FROM ANY RAILROAD DEPOT



Typical room, converted at night into a sleeping room.

*Enjoy the Comfort of a  
Real Home in*

NEW YORK'S FINEST  
RESIDENTIAL HOTEL

*The*  
**GEORGE WASHINGTON**  
*Lexington Ave. 23<sup>rd</sup> to 24<sup>th</sup> St.*

Only a few quick minutes from business, shopping and amusement centers, yet you will enjoy the quiet repose of a country town at evening. Such is the fortunate location of the George Washington Hotel, a distinguished residential hotel.

**ROOM WITH BATH**  
DAILY \$2.50 to \$3.00 WEEKLY \$14 to \$17.50  
THE BEST FOOD IN NEW YORK



**\$5,000 WILL BE PAID TO ANYONE WHO PROVES THAT THIS IS NOT THE ACTUAL PHOTO OF MYSELF SHOWING MY SUPERB PHYSIQUE AND HOW THE ROSS SYSTEM HAS INCREASED MY OWN HEIGHT TO 6 FT. 3 3/4 INCHES. HUNDREDS OF TESTIMONIALS. CLIENTS UP TO 45 YEARS OLD GAIN FROM 1 TO 6 INCHES IN A FEW WEEKS!!**



First in 1907  
First To-day

No Appliances—No Drugs—No Dieting. ROSS SYSTEM NEVER FAILS. Fee Ten Dollars Complete. Convincing Testimony and Particulars 5 cents stamps. Allow time for return mails across the Atlantic. G. MALCOLM ROSS, Height Specialist, Scarborough, England, (P. O. Box 15).



### Become a Reporter!

Thousands of opportunities for young men to enter the Newspaper field. Fascinating work. You will meet interesting people; interview celebrities. A famous New York reporter with twenty years of practical experience has written a whole course of journalism and reporting in six easy lessons. He shows you the short-cut to success. He tells you what to do and what not to do, to become a successful reporter. Send today for the "PRACTICAL COURSE IN JOURNALISM," by Henry John Brockmeyer of *The New York Evening Post*. Just drop us a Postal Card—no need to send money. We will mail you the whole set of six books and you pay the Postman \$3.00 plus a few cents for postage. No more to pay. Money absolutely refunded if not satisfied.

P R E S S G U I L D

16-E Murray Street Dept. D-831 New York

Be sure to read the announcement on page 70 of this issue which tells the important message about the first three Supplements to the OFFICIAL RADIO SERVICE MANUAL.



## HOTEL DIRECTORY OF THE RADIO TRADE

### WELCOME to NEW YORK and The HOTEL GOVERNOR CLINTON

31<sup>ST.</sup> ST. AND 7<sup>TH.</sup> AVE.  
opposite PENNA. R.R. STATION

1200 Rooms each  
with Bath, Serv-  
idor and Circulat-  
ing Ice Water.

ROOM AND BATH 3<sup>00</sup> UP

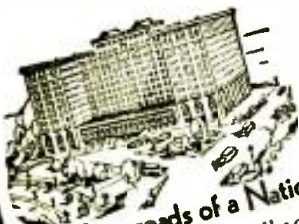

### The Crossroads of a Nation

THE DRAKE is admittedly one of the great hotels of the world... the stopping place of seasoned travelers. Rooms are spacious and smartly elegant... continental in atmosphere. Available, also, is an experienced Travel Bureau... to relieve you of every travel detail. Rates begin at \$4 per day. Permanent Suites at Special Discounts.

THE  
DRAKE  
HOTEL, CHICAGO  
Under Blackstone Management

"AN ADDRESS OF DISTINCTION"

Full details about the OFFICIAL RADIO SERVICE MANUAL and the RADIO SERVICE MAN'S HANDYBOOK appear on page 116 of this issue. If you have not yet familiarized yourself with the contents of these important radio servicing books do not fail to read the announcement which tells all about them.

resistance of the tube and causes rapid deterioration.

The complete system, as shown in the diagram, will make an ideal installation for auditorium or open-air use, where a high quality of output at a high power level is needed. The two amplifiers may be remote from one another and connected by a twisted pair. If an exceedingly long line—a mile or two—is necessary, the loss in high-frequency response due to the line may be easily compensated by adjustment of the tone-compensated amplifier. Where a microphone is employed, an additional booster stage will be necessary. This may well be battery-operated and incorporated in the microphone stand. (The design of such booster equipment is described in detail in the article, "A Public-Address Adapter Unit," by Howard Smith, in the October issue of RADIO-CRAFT.—*Technical Editor.*)

If there is sufficient interest in this class of equipment, the writer will be pleased to furnish details on subsidiary apparatus such as mixing panels for several microphones or a combination of microphones, phonograph pick-ups and radio, together with volume-level indicators, etc.

The DeForest tubes employed are obtainable without the slightest restriction, and are guaranteed for a life of 1000 hours.

#### List of Parts Used

One Amertran 245 power block (PT1, L1, L2);  
One Amertran AF-8 transformer (T1);  
One Amertran 3332 output transformer (T2);  
One Amertran 3842 choke, 300-henry (L3);  
One Amertran 641 choke, 400-henry center-tapped (L4);  
Five Electrad "Supertonatrols": four No. 3, 50,000-ohm (R1, R2, R3, R5); one No. 5, 100,000-ohm (R4);  
One Electrad 1,500-ohm flexible resistor (R6);

Three Electrad enamelled resistors: one 100,000-ohm (R-7); two 50,000-ohm (R8, R9);  
One Electrad Truvolt B-8 resistor, 800-ohm (R10);  
Two Polymet 400-V fixed condensers, 2-mf. (C1, C6);  
Three Polymet 200-V fixed condensers; two 1-mf. (C3, C4); one 4-mf. (C7);  
Two Polymet fixed condensers, .01-mf. (C2, C5);  
One Polymet condenser block, 2-4-4-mf. (C8, C9, C10);  
One De Forest type-427 audion (V1);  
Two De Forest type-445 audions (V2, V3);  
One De Forest type-480 rectifier (V4);

#### 50-Watt Amplifier

One Electrad TS-500 line pad (P1);  
One Amertran No. 3664-line-to-tube transformer (T3);  
One Amertran No. 4116A tube-to-line transformer (T4);  
One Amertran 11-4201 filament transformer (PT3);  
One Amertran P-4656 plate-supply transformer (PT2);  
One Amertran 557A filter reactor (L5, L6);  
One Amertran No. 3377 autotransformer (L7);  
One Electrad C-10 resistor 1,000-ohm, (R11);  
One Electrad D-500 resistor, 50,000-ohm, (R12);  
One Electrad "Truvolt" 400-ohm potentiometer (R13);  
Two Pilot condenser blocks, 1-mf. per unit (four in C11, six in C12);  
One Pilot condenser, 4-mf. (C13);  
Two Weston D. C. meters: one 0-500-ma., M1; one 0-10-ma., M2;  
Four Carter closed circuit jacks (J1, J2, J3, J4);  
Two De Forest type-545 audions (V5, V6);  
Two De Forest type-566 mercury-vapor rectifiers (V7, V8).

## Modernizing Old Radiola Supers

(Continued from page 99)

#### Altering Other Models

Most of the data given above apply also to the "AR-810" and "AR-812" series of receivers. However, inasmuch as the internal construction of the latter receivers is different from the "25," detailed instructions will be given below for the "AR-810" and "AR-812" series.

Remove the cat from its container, as previously described for the "25" and "28," (but do not remove the whiskers from the small holes in the panel).

The first thing to do is to locate a grid return for the sixth tube. Turn the unit right side up, with whiskers away from you; note the one long machine-screw to the right. On the top side a wire joins the extreme left screwhead—remove this wire. Now run a hot soldering iron down around the extreme right screw, melting the wax on both sides and rear; you will find two wires making contact to this screw. That at the right is the grid return for tube No. 6—leave it as connected. Cut the lead at the left, which is the grid return

to tube No. 5. In case of doubt concerning these wires, you can run a continuity test between the grids, of sockets 5 and 6, and the grid returns. The grid return of socket No. 5 is connected to the extreme-left machine-screw, which has a wire leading to hole No. 6. The head of the extreme-right screw (top side) is the return for socket No. 6. A tone-control connection is obtained by soldering a wire to the thin strip which is second from the right. This connection is completed as described for the "25."

The procedure in locating the "B+" connection for tube No. 2 of the "AR-812" is slightly different from that with the "25." Turn the unit right side up, with the whiskers toward you. Between sockets 3 and 4 is a bakelite stud; just behind this is a connection marked 10. Cut this wire; the left end is "B+" for tube No. 2; the right end is left connected to No. 10. The "outside" terminal No. 6 is connected to "outside" No. 10 ("A+") to complete the grid return for tube No. 2.

The grid leak of the second detector is

found connected from grid to filament; while the grid condenser is in series with the lead. Cut the pigtail leads to the red carbon grid leak, and short the grid condenser with a wire, as before, so that a grid bias may be applied. Next, the "grid-return" wire which is soldered to the core of the third I.F. transformer, must be located. Turn the unit right side up; and run a hot iron along this core, gradually working upward between it and the first A.F. transformer core. The grid return is soldered to an eyelet, on the core of the third I.F. transformer; the wire is very fine—be careful. Remove, and solder to it a fine wire bringing it out through the panel, for the "C-12" connection.

The cat. now may be replaced in the container.

You will have four extra connections which are to be connected to free soldering lugs, after other changes have been made; one of these extra wires is the tone-control lead. If a '33 pentode is used, a fifth extra connection must be provided for the suppressor-grid lead. The three leads to be connected to free lugs are the "C-13½"; "C-12"; and "B+45" (for tube No. 2). To get a "B+135" connection for tube No. 6, remove the wire between "outside" No. 12 and the jack J1; cut the lead from jack J1 to switch No. 2, at the switch, and reconnect it to "outside" No. 2 (which will be "B+135" for socket No. 6.) Switch No. 2 is not needed; and the three wires leading to it may be cut short at the switch, after they have been removed from "outside" leads 13, 14, and 15.

"Inside" No. 12 is now connected to the same screw-head as "inside" No. 13; the wire through hole No. 13 can now be removed altogether. (Connecting 12 to 13 merely connects the "P" of the transformer directly to the plate of socket 5, instead of this connection's being completed externally by switch SW2.) We now have two free holes—12 and 13. Connect a wire from the screw-head behind socket 6 and bring it through hole 13 for the "C-13.5" connection. Hole No. 12 can be used for either the tone-control or the suppressor-grid lead.

Bore smaller holes alongside the others, for the "C-12" and "B+45," of tube No. 2; connect these to free lugs 14 and 15 respectively.

Battery connections to the lugs are as follows: lead No. 10, "A+B-"; 8, "A-C+"; 15, "B+45"; 12, "B+90"; 2, "B+135", for power tube; 11, "B+135" (for second detector); 6, "C-4.5"; 13, "C-22.5"; 14, "C-12" negative."

#### Use of Adapters in UV Sockets

Before the two-volt tubes can be used in the "AR-810" and "AR-812" series, it will be necessary to procure seven adapters; six of the Na-Ald "Type 999," and one "Type 934." In socket 3, you will have two adapters; one of the "999's," and the "934" with attached 1,000-ohm resistor. If a pentode '33 tube is used as the last stage A.F. amplifier, a No. "999" adapter will not be required here; since you will be using a UY 5-prong socket.

A '33 pentode tube can also be used on the remodeled "28," by including an extra 5-prong socket as described for the "AR-812" and "25," and applying the proper grid

voltages. A further improvement in the "28" may be made by shorting the grid leak and condenser of the second detector. The grid return is found by melting the wax with a hot soldering iron, as described above for the other Radiolas.

If the filament supply is a 6-volt storage battery, insert a 7-ohm resistor between "A—" of the battery and the "A—" connection of the receiver. If two dry cells are the "A" source, use a 1½-ohm resistor. If an Air-Cell battery is utilized, the receiver rheostats can be adjusted to give correct voltage. The filament voltage should be checked often with a good high-resistance voltmeter, to insure long life of the tubes; it should not rise above 2.1, nor fall below 1.8 at any time.

(In his previous article on the "28," Mr. Sprayberry pointed out the convenience of Amperites as filament-current controls. The present story, however, covers a large number of tube combinations; each with a different current requirement. Nevertheless, these automatic resistors are available with any rating desired for the circuit and batteries used.—*Tech. Ed.*)

#### An Outside Antenna

Using an indoor aerial about 60 feet long, the writer tuned in stations as far south as Florida, as far north as Montreal and as far west as Los Angeles, with the receiver located in the basement of his home in Washington, D. C.

An "antenna coupler" (Fig. 2) was used. It was wound with a secondary of 55 turns of No. 24 D.C.C. wire on a 2½ in. tube; and 15 turns for the primary. The aerial was connected to one end of the primary, the other end of which was connected to center of the secondary and to ground. A wire was also connected from this point to the negative side of the filament circuit, to decrease body capacity. The secondary leads were then connected across the loop compensating condenser, which is located at the left end of the chassis, as shown in the former article on the "28".

After constructing and connecting the antenna coupler, the compensating condenser (C, Fig. 1 of the former article) is adjusted; it is above the neutralizing condenser. Tune the receiver to the signals of a weak station and adjust with an insulated screwdriver for maximum volume; do this at several points on the dial. A point will be found, with reference to others on the dial, where maximum signals will be obtained. If the dial reading for a given station is not the same for maximum volume as when the loop is used, it may be necessary to add or subtract a secondary turn of the antenna coupler.

A similar type of antenna coupler may be used for the "AR-812" and the "25" models, connected as in Fig. 1; without the center tap, as may be seen. The latter, however, will be required with the "28," if the loop is to be used at times. Much better results are obtained, however, with the loop connections removed from all models.

The coupler used with the '28, as shown in Fig. 2, has its secondary directly across the compensating and tuning condensers which resonated the loop. If the center tap is not to be used, the "C-4½" bias will be applied to the filament side of this

## Just Out —

# NA-ALD

New Adapters for testing Pentode tubes in your present analyzer or checker.

Latest Price Sheet—showing hundreds of adapters of interest to service men, experimenters, inventors and manufacturers.

New Analyzer Plug that locks to adapters.

ADAPTERS for pickups, microphones, voice recording outfits, short wave sets, tone control, tube changes, the new 2-volt tubes, set analyzers and tube checkers.

SOCKETS for replacement and experimental work.

SPEAKER PLUGS, multi-wire cables and outlets.

Send for Price Sheet Today

ALDEN MANUFACTURING CO.

Operated by Alden Products Company

715 Center Street Dept. T

Brockton

Mass.



"It's the contact that counts"

### CLASSIFIED ADVERTISEMENTS

#### BUSINESS OPPORTUNITIES

\$200 WEEKLY. Building, operating Miniature Golf Courses. Lawrence, 419 Erie Bldg., Cleveland, Ohio.

#### DETECTIVES

DETECTIVES Earn Big Money. Excellent opportunity. Experience unnecessary. Particulars Free. Write, George Wagner, 2190B Broadway, New York.

#### ELECTRICAL

ELECTRIC FUN! 200 stunts, 110 volts, \$1.00. Curring Sons, Campbell, Calif.

#### FORMULAS

MAKE AND SELL your own products. We will furnish you any formulas. Write for our literature. Chemical Institute, 19R Park Place, New York, N. Y.

#### PERSONAL

IF YOU want to get acquainted? Send for my big (free) list of introductions! One may be your ideal. Box 100 N.A.A. Detroit, Michigan.

#### PRINTING

200 BUSINESS Size Letterheads, 150 Standard envelopes, printed to order \$2.00 prepaid. Central Printing Company, Box 7623D, Kansas City, Mo.

#### RADIO

SERVICE MEN. ATTENTION—Speakers re-wound, magnetized, repaired, \$2.00 to \$2.75. Complete Power Pack Service—Transformers re-wound, condenser blocks repaired, resistors duplicated. Guaranteed. Clark Brothers Radio Co., Albia, Iowa.

SERVICE SHOPS—we specialize in rewinding power transformers. Try us. Supreme Radio Laboratory, 16 Fulton Ave., Rochester, N. Y.

#### SONG POEM WRITERS

SONG Poem Writers. Composer of many hits offers wonderful opportunity. Ernest Shonfeld, 1920, 455 Alvey, Pasadena, Calif.



# SKINDERVIKEN



**The Most Sensitive Microphone Button**  
(ACTUAL SIZE NOT BIGGER THAN A QUARTER)

You can easily make a highly sensitive detectophone by using a Skinderviken Transmitter Button to collect the sound waves. You can build your own outfit without buying expensive equipment. Think of the fun you can have with such an instrument.

You can install an outfit in your home and hear the conversation being held all over the house.

Full directions for connecting up the button for use as a detectophone are given in our 12-page booklet.

These wonderful little SKINDERVIKEN microphone buttons may be used for hundreds of uses, such as:

- |                              |  |
|------------------------------|--|
| RADIO AMPLIFIER DETECTOPHONE | PHONOGRAPH AMPLIFIER TELEPHONE AMPLIFIER |
| STETHOSCOPE                  | LOUD SPEAKER AMPLIFIER                   |
| MICROPHONE                   | CRYSTAL SET AMPLIFIER                    |
| HOME RECORDING OUTFIT, ETC.  |  |

**95c EACH**      Two for **\$1.75**  
**12-PAGE INSTRUCTION BOOKLET**  
containing suggestions and diagrams for innumerable uses, furnished with each unit.

EVERY AMATEUR SHOULD HAVE TWO OR THREE OF THESE AMPLIFIERS IN HIS LABORATORY

WE PAY \$5.00 IN CASH for every new use developed for this unit and accepted and published by us.

## SEND NO MONEY

When the postman delivers your order you pay him for whatever you have ordered, plus a few cents postage.

(Canada and Foreign: cash with orders)

PRESS GUILD, Inc., RC-831  
16 Murray St., New York, N. Y.

Please mail me at once as many of the following items as I have indicated.

...Skinderviken Transmitter Units at 95c. for 1; \$1.75 for 2; \$2.50 for 3; \$3.20 for 4.

When delivered I will pay the postman the cost of the items specified plus postage.

Name .....

Address .....

City..... State.....

## Radio Dealers! Radio Service Men!

Guaranteed Replacement Condenser Blocks and Transformers

Atwater-Kent 37 Cond. Block with chokes	Net \$3.95
Atwater-Kent 37 Power Transformer	2.95
Atwater-Kent 40 Pack Complete	7.50
Zenith ZE9, Stewart-Warner, Mohawk Blocks	3.45
Majestic "B" Eliminator Cond. Block	2.95
Crosley Electrolytic Condenser, 2 Anode	2.10
Crosley Electrolytic Condenser, 3 Anode	2.75

Hard-to-get parts—We have them  
Send us your repair work for estimate

Write for our FREE CATALOGUE

Grant Radio Laboratories  
6521 1/2 South Halsted St., Chicago, Ill.

winding, as in Fig. 1. A 50,000-ohm potentiometer may be advantageously shunted across the primary, as indicated in Fig. 1, to serve as a volume control; this will, of course, be mounted on the panel.

Alternative specifications for the coupler are 25 turns of No. 26 D.C.C. for the primary, spaced 5/8-inch from a 48-turn secondary, on a 2 1/2-inch tube. This will be less selective, and the local reception conditions must be taken into consideration. (Other specifications for such a coil may be taken from Table II, on page 55 of last month's RADIO-CRAFT.)

The writer wishes to take this opportunity to thank the great number of RADIO-CRAFT readers who wrote to him in connection with the "23" story (and possible treatment of the "25" and "812,") for their helpful and considerate attitude. It is hoped that this story will be as well received, and will be of equal value to owners of the early-model Radiola superheterodynes.

## Two-Volt Tubes

(Continued from page 101)

be made quite compact and tucked away in a corner of the console. The ballast lamps are best mounted outside the cabinet, as they develop a fair amount of heat when totally enclosed. The negative side of the light line is connected to the "A—" lead of the receiver; this means that the chassis will now be alive—electrically speaking. It is

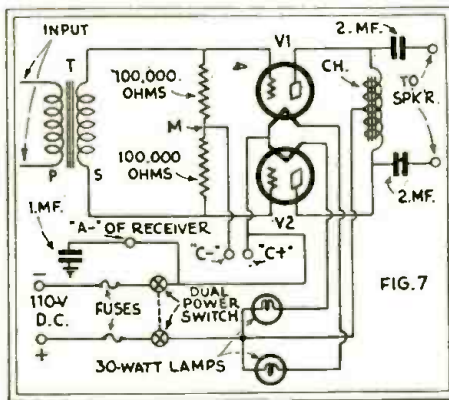

Mr. Oldroyd's 110-volt D.C. amplifier works from his 2-volt battery set, with tubes like 71As; an experimenter might see what is possible with the new '38 D.C. pentodes.

essential that a condenser of about .005-mf. capacity be placed in the antenna lead, as well as a 1-mf. condenser in the ground lead, since one side of the light-line is grounded.

Even on exceedingly "rough" lines, such as the writer is forced to use, no hum will be heard from the speaker, provided the tubes are well matched.

Now, with a power amplifier of the kind described, we have all the output we require from the receiver, and free from distortion too; while the two-volt tubes are more than able to take care of the earlier stages of the set, where they have to deal with voltage amplification only.

Incidentally, the battery will be relieved of the additional drain imposed by the power tubes and, when the filaments are fed from one of the new air cells, this is no mean advantage.

- - no greater magazine published on development of Television - -

Published every other month



On All Newsstands

TIMELY developments in radio's latest wonder, Television, are published in every issue of TELEVISION NEWS—Mr. Hugo Gernsback's latest magazine. Rapid advancement in this art today is becoming a repetition of the radio cycle of years ago. Daily broadcasts are becoming more numerous and experimenters are following in quick order in building television sets for experimental purposes. Foresight of its development can be seen by the pioneers of radio—they are equipping themselves now with television experience.

The articles published in TELEVISION NEWS are of primary importance to experimenters—they are simple in construction, understandable and replete with diagrams, photographs and illustrations.

### A Brief Summary of the Contents

- The Jenkins New York Studio Television Here and There
- How I Get Television on a Broadcast Receiver
- The Glow Tube Problem in Television
- How a Cathode Tube Scans in Television
- Jenkins Television Projector
- How to Build a Scanner
- Short Course in Television
- Principles of Scanning
- Color Television Transmitter
- Some of the Problems of Television
- The "Find-All" Television Receiver

COMPLETE TELEVISION COURSE

Over 200 illustrations, Diagrams, Circuits and Photographs—Actual Television Transmitters and Receivers.

### FULL DETAILS IN COUPON ABOUT SPECIAL OFFER

TELEVISION NEWS RC-8  
98 Park Place, New York, N. Y.

Enclosed find \$2.00, check or money order preferred, for which you are to send me TELEVISION NEWS for One Year (Canada and foreign \$2.50). I understand that the regular subscription price is \$3.00 and this Special Offer will be void after July 31st.

NAME .....

ADDRESS .....

CITY AND STATE .....

TRY-MO RADIO carries the largest and most complete stock of speakers, pick-ups and speaker accessories. Specialists in speaker repairs, we can repair any speaker. Write for our estimate. We can build power amplifiers and public address systems to any specifications. We can supply any thing in radio. Write us for our price.

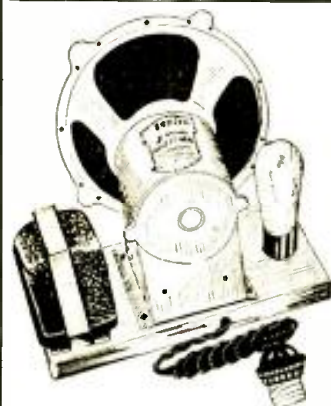

### Jensen Dynamic Speaker

Jensen Speakers are noted for the quality. Standard equipment on the highest priced radios.

Concert Jr. Model with 280 rectifier	<b>\$13.50</b>
Concert Model D8-110V A. C.	<b>\$14.95</b>
Concert Model D7-110V D. C.	<b>\$7.50</b>
Concert Model D9-110V D. C.	<b>\$7.95</b>
Midget Model D12-110V D. C.	<b>\$5.95</b>
Midget Model, 6 Volt D. C.	<b>\$5.95</b>

### Radiola Speakers

#### Model 106

Famous R. C. A. speakers in models for every set.

Model 106 with 280 rectifier	<b>\$12.50</b>
Model 106, 200 Volt D. C. with output transformer	<b>\$5.50</b>
Same as above but less output transformer	<b>\$4.50</b>
Model 106, 110 Volt D. C. field	<b>\$7.50</b>
Model 100A Magnetic Chassis	<b>\$2.75</b>



### Loftin White Amplifier

Licensed



Loftin White amplifiers in striking modernistic finish. Ideal for phonograph or public address work.

245 Model uses 1-224, 1-245, 1-280	<b>\$12.50</b>
250 Model uses 1-224, 1-250, 1-281	<b>\$15.95</b>

### Hammarlund Variable Condenser

Straight line frequency. .0005 mfd. maximum capacity. Brass soldered plates, low loss construction

Special at **95¢**



### Tips-Jacks-Plugs Handy Connectors

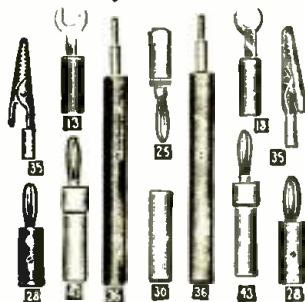

Complete Kit—\$2.00 As Shown.

These are the finest connectors ever made. Insulation colored for easy identification.

No. 35—Crocodile Jaw slip, fits Nos. 25, 23, 42	<b>10¢</b>
No. 13—Spade Terminal for Nos. 28 and 42	<b>15¢</b>
No. 25—Plug with chuck to hold phonograph needle for testing	<b>15¢</b>
No. 2—Plug with tip for branch connection	<b>15¢</b>
No. 43—Plug with long shank	<b>20¢</b>
No. 36—Universal Test Prod	<b>25¢</b>
No. 30—Coupling for No. 25 to No. 42 or No. 36	<b>15¢</b>

Order by number. All other types in stock. Write for complete list.

### Peerless Dynamic Speakers

#### Peerless DYNAMIC SPEAKER CHASSIS

Peerless, the finest of dynamics at big savings. Sonora Model with double A. C. rectifiers as illustrated.



Peerless 14" 110 V. D. C.	<b>\$19.50</b>
Peerless 14" 110 V. A. C. with 280 rectifier	<b>\$14.50</b>
Peerless 14" 110 V. A. C. with 280 rectifier	<b>\$17.95</b>
Peerless 12" 110 V. D. C.	<b>\$7.25</b>
Peerless 12" 110 Volt A. C. with 280 rectifier	<b>\$14.50</b>

### Shielded

#### Radio Frequency Chokes



Mounted in copper shielding can. Single screw mount. Available in 85 or 50 millihenry **95¢**

### Amplion Hand Microphone



Single button hand microphone of the transverse current type 500 ohm type. Very sensitive and stable. A real buy at **\$4.95**

### Best De Luxe Theatre Pick Up



Unexcelled for tone quality reproduction, the BEST stands far above any other pick-up. Volume control is built in conveniently on the base **\$7.25**

### Farrand Inductor Dynamic



One of the best sounding speakers. Requires no power for field excitation. Reproduces with dynamic quality.

9" speaker	<b>\$6.95</b>
12" speaker	<b>\$7.95</b>

### Faradon Condenser Blocks



12 mfd. block tapped at 5, 5, 2 mfd. Working voltage 600 D. C.	<b>\$1.95</b>
7 mfd. Working voltage 300 D. C.	<b>79¢</b>

## BARGAIN LISTING OF LAST MINUTE SPECIALS

Carryola Pick up Head	<b>\$2.49</b>	Benjamin 5 prong sockets	<b>.35</b>	0-600 D. C.-A. C.	<b>\$3.25</b>
Powertone 2 way Relay	<b>.75</b>	B. B. L. Magnetic Chassis	<b>\$3.25</b>	SANGAMO AUDIO TRANSFORMERS	
Powertone 4 way Relay	<b>.99</b>	B. B. L. Magnetic Unit	<b>\$2.95</b>	Type BX push pull input	<b>\$1.95</b>
Powertone Tone Control	<b>\$1.50</b>	FLECHTHEIM METERS		Type HX push pull output	<b>\$1.95</b>
Powertone Tone Control for panel mount	<b>\$1.05</b>	0-300 Volts D. C.	<b>\$1.95</b>	Type BX and HX, per pair	<b>\$2.75</b>
Air King Short Wave Coils, set of 4	<b>\$1.59</b>	0-500 Volts D. C.	<b>\$2.50</b>		

Speaker Specialists

**TRY-MO RADIO CORP.**  
177 Greenwich St., New York City

Amplifiers Designed To Specifications



# CROSLEY Electro Dynamic Speakers

FIRST TIME SOLD AT THIS PRICE

YOUR CHOICE **\$6.50** Net



Model "A"—7" Chassis housed in beautiful metal cabinet Equipped with output transformer.  
 Model "B"—Same as Model "A" Chassis only.  
 Model "C"—9" Chassis with 900 ohm field and output transformer. Can be used with any set employing 1-171A or 1-245 power tube. Also can be used in Majestic Model 71.  
 Model "C"—9" Chassis with 725 ohm field and push-pull output transformer.  
 Model "E"—6 Volt Chassis for operation on storage battery or "A" eliminator. 85 ohm field and push-pull output transformer. Can be used with sets using the new 232 tubes. Can be converted for A.C. by use of a step-up transformer and 280 tube.

# CROSLEY Type F Dynacone Speaker



This Crosley Speaker is meeting the increasing demand for an automobile radio reproducer which can be expected to give a full measure of satisfaction. Dynamic Tone!

OUR PRICE

**\$2.95** Net

## MUSIC MASTER Model "PETITE"

110 Volt A.C. 50-60 Cycle  
**THE SMALLEST**  
 17" x 13" x 7 1/2"  
**THE LIGHTEST**  
 Net 18 1/2 lbs. Ship'g. Weight 23 lbs.  
**THE MIGHTIEST**  
 in performance.



That, briefly describes this NATIONAL- LY and INTERNATIONALLY FAMOUS Midget Receiver. Made by a well known manufacturer. FULLY GUARANTEED to us and by us.

The chassis is a masterpiece of compact radio engineering, sturdy, clean construction. Uses three 224 screen grid, one 245 Power and one Rectifier tubes, Loftin-White amplification, Electrolytic Condensers, Magnavox or Jensen Dynamic Speaker, and all housed in a beautiful Walnut Veneer Cabinet of graceful lines.

The manufacturers' price is \$49.50 less usual trade discount.

OUR NET PRICE **\$25.45**

Optional: A set of good tubes supplied with each Receiver at \$1.25 additional. Convince yourself of the tremendous value of this offer. Order samples at once, examine and test them, your order for as many as you can handle will follow quickly.

## GENERAL ELECTRIC HIGH VOLTAGE FILTER CONDENSER

3 MFD. — 800 VOLTS  
 Size: 5x2 3/4 x 1 Inch.



Encased in a sturdy metal container with 8 inch flexible insulated wire leads. Equipped with handy mounting brackets.

OUR PRICE **95c** Net

**\$10.00** per dozen

## MAXIM "Silent" Power Supplies Reduced



DRY "B" POWER

Contains no liquids. A distinct radio bargain that will be of interest to the experienced radio buyer. (Complete with tube.) For A.C. Current.

OUR PRICE **\$6.50**

Net



DRY "A" POWER

Regardless of price no finer "A" Power Eliminator can be procured. No need of bothering with expensive "A" batteries. Complete—for A.C. current.

OUR PRICE **\$9.00**

Net



DRY "A-B" POWER

Ultra modern design. Compact. Simple to install. Only one switch. Comes complete with a 280 tube ready to operate.

OUR PRICE **\$16.50**

Net

## SONORA ELECTRIC MOTORS WITH 12" TURNTABLES



FULLY ASSEMBLED and MOUNTED

on 1/2 inch thick, warp proof, five-ply boards, size 15 x 15, ready to install into cabinet. These motors are absolutely NOISELESS, of very rugged construction, operate on 110 volt A.C. current, and are equipped with Speed Regulator and 6 foot cord and plug. The 12" turntable will take any standard size record.

By a special adjustment (at no extra cost) these motors will operate on D.C. current. Please specify when D.C. current is wanted, otherwise A.C. motors will be supplied.

An exceptional Value.

OUR SPECIAL PRICE **\$9.75**

## RADIART STEP-DOWN TRANSFORMERS

INPUT 220-250 Volt 50-60 cycle A.C.  
 OUTPUT 110-120 Volt, Rated at 150-160 Watt



For use in localities where 220 volt, 60 cycle A.C. current is supplied. These Transformers adapt current of that voltage to any A.C. Radio or other Electrical Appliance which consumes up to 160 watts. Encased and easily mounted. Size: 4x3 1/4 x 5 3/4" Ship'g w't: 6 1/4 lbs.

VERY SPECIAL

**\$3.75**

## List \$5.00 NATHANIEL BALDWIN RIVAL UNIT



OUR PRICE

**65c** Net

This Nathaniel Baldwin unit is one of the finest made by that company. Can be used for Phonograph, Automobile and Portable Radio Outfits. Order your supply today before it is too late.

## JENSEN "CONCERT" D. C. ELECTRO DYNAMIC SPEAKERS

Model D 7 D C 10" Diameter  
 2500 ohm field 8 ohm voice coil



These units contain suitable push-pull transformers and are absolutely hum-free. Connect directly to the set, no outside wires.

As most standard manufactured A.C. sets are re-engineered for D.C. speakers of this ohmage, the possibilities for replacement with this really good speaker are practically unlimited.

The wise merchant or repair-man will take advantage of this real "buy". Never before offered at a cut price. The quantity available at this price is limited. Act quickly.

List \$27.50

OUR NET PRICE **\$7.90**

Original factory packing of 2 in a carton.

All offers are F.O.B. New York, and subject to prior sale. Terms: A deposit of 20% is required with every order. Balance may be paid on delivery. Or, deduct 2% if full amount is sent with order.

**DO NOT WRITE FOR CATALOG!**

**GRENPARK CO., Dept. RC, 245 Greenwich Street, New York, N.Y.**



# QUALITY! SERVICE! PRICE! SATISFACTION!

A COMBINATION THAT A DEALER CAN NOT DO WITHOUT AND BE SUCCESSFUL

THOUSANDS of dealers throughout the entire world have found it profitable to deal with THE RADIO SURPLUS CORPORATION. We pride ourselves on our service and merchandise quality. The items listed here are just a sample of values to be found throughout our 48 page book, a copy of which is yours for the asking. Where quality, service and price are factors, you may depend on us to give complete satisfaction. We have the most complete line of replacement parts in stock and feature short wave receivers, transmitters and public address equipment of all types and for all purposes. There will be a great demand this summer for public address systems. It will be to your advantage to cash in on this demand now. Our listing of electric accessories is complete and offers a new source of profit to the progressive dealer. Order from this page. Orders are filled the same day received.

## Reliable Senior Set Analyzer



A three meter job that will perform every necessary test. Test all tubes including pentode and 280. Charts furnished enables measurements of capacity and resistance.

Meters can also be used individually.

A real buy.

**YOUR PRICE \$14.70**

## Guaranteed Reliable Tubes

These tubes are guaranteed 15 days from date of purchase. All tubes triple tested.

5% discount in lots of 30 or more.

U X 201A	30¢ each	U X 171A	45¢ each
U X 226	35¢ each	U V 199	50¢ each
U Y 227		U X 120	
U X 215		U X 200A	
U X 280		U X 112A	
U X 221	75¢ each	W D 11	1.59 each
Pentode		W D 12	
U X 217		U X 230	
U X 222		U X 231	
U X 291	1.10 each	U X 232	1.59 each
U X 250		B. H. Raytheon	
U X 210			
U X 235			



## Pentode Midget Set R. C. A. Licensed

The latest in midgets. Uses Pentode Power Tube, two Multi-Min Super Control Screen Grid tubes, a screen grid 224 and a 280 rectifier. Has a static reducer, full vision dial, antenna compensation and local, distant switch. Uses a full range Jensen dynamic. Complete with RCA licensed Triad tubes and cabinet.



Complete with tubes — nothing else to buy.  
**YOUR PRICE \$27.75**

## Toggle and Jack Switches



The switches listed are made by H. & H. Bryant General Electric, Cutler Hammer, etc.

S. P. S. T. Toggle	ea.	.16
S. P. D. T. Toggle	ea.	.22
Double Circuit Toggle	ea.	.35
Carler S. P. D. T.		
Phone Switch	ea.	.19
Carter 4 pole D. T.		
with Neutral position	ea.	.69
Cutler Hammer Three Point Toggle	ea.	.35
Long neck Toggle	ea.	.23
Bryant Rotary Switch	ea.	.16
Carter Television Switch	ea.	.15
Cutler Hammer Lock Switch	ea.	.25

In lots of doz. or more less 10% of above price.

## Variable Volt-amp Dividers



75 Watt rating for use in all power packs.

10,000 ohm, 2 sliders	59¢
<b>YOUR PRICE</b>	
25,000 ohm, 3 sliders	72¢
<b>YOUR PRICE</b>	
50,000 ohm, 6 sliders	89¢
<b>YOUR PRICE</b>	
Bradleyometer 400 ohm Per-	
tentimeter, 25 watt	95¢
<b>YOUR PRICE</b>	

## Neutralizing Tools



Used for neutralizing and aligning condensers. Fits all standard receivers.

Five foot long with insulated polarity prods. For the service man.  
**YOUR PRICE 35¢**

## Pentode Adapters

Make your set modern at a cost at most nil. No labor whatever. Replaces all 215 tubes with the Pentode. No need to touch wiring. Just plug adapter into 245 socket and Pentode into 245 socket, to get the full benefit of the Pentode tube.



**YOUR PRICE \$1.29**

## Allen Hough Phonograph Motor



The Allen motor is priced so low that now you can afford to make combinations up very cheaply. Starts at flick of the finger. For 110 volts 60 cycle A. C. only. The most compact motor made.

**YOUR PRICE \$2.95**

## Webster Pick Up



The finest reproducing pick up unit made. Reproduces evenly over the entire range. Scratch noise kept to a minimum. Volume control built into the base. Oxidized bronze finish.

**YOUR PRICE \$4.95**

## Victor 2 Stage 245 Push Pull Amplifier



This is the same amplifier as used in Victor 1132, 1132, RE45, and RE75. Uses 1-226, 2-245, and 1-280. Has tone control, D. C. speaker field outlet and plate and filament power supply for tuner. Will operate with any speaker. Special while they last.  
**YOUR PRICE \$12.50**

# FREE

As a special offer to the serviceman and dealer who should have this utility resistance kit, we are giving this \$2.50 resistance ohm meter absolutely free with each serviceman's resistor kit ordered at our regular price of \$2.25. This offer is good only this month. ONLY ONE TO A CUSTOMER.

**SEND FOR OUR WHOLESALE RADIO CATALOG**

## Pentode Amplifier Loftin White Licensed



Far superior to the regular Loftin White 245 amplifier, this Pentode amplifier gives more volume with greater power handling capacity. Ideal for all public address systems. Uses 1-224, 1-247 Pentode and a 280 rectifier.

**YOUR PRICE \$17.50**

## Faradon R. C. A. Condensers

Made by Faradon for R. C. A. Victor. Impregnated. 650 volts D. C. ratings.

.1 mfd.	15¢
.25 mfd.	15¢
.5 mfd.	15¢
1 mfd.	20¢
2 mfd.	20¢
4 mfd.	25¢
.5-C-.5	20¢

## Reliable 245 Power Transformer

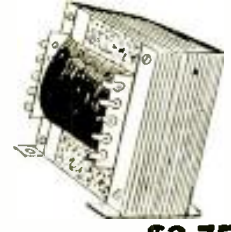

**YOUR PRICE \$2.75**

## Super Het Intermediate Transformers



These intermediates peak at about 175 K. C. with a 220 mmfd. condenser. Wound on a convenient mounting core.  
**YOUR PRICE 19¢**

## R. C. A. Super Het Intermediate Tuning Condenser



Designed for use with the super-het intermediate transformer. Mounted on insulating base of isolanite. Capacity 145 to 220 mmfd.  
**YOUR PRICE 69¢**

## Reliable 250 Power Transformer



**YOUR PRICE \$5.25**

## General Electric Double Filter Choke



D. C. resistance 500 ohms per choke, 50 henry at 80 milliamperes.  
**UNSHIELDED. YOUR PRICE \$1.15**  
**SHIELDED. YOUR PRICE \$1.95**

## ORDER FROM THIS PAGE

We sell wholesale and cannot accept orders for less than \$5.00 if C. O. D. shipment is desired, please remit 20% balance on delivery. We reserve the right to ship via express collect any order on which insufficient postage has been remitted. If shipment is to be made via Parcel Post be sure to enclose enough for postage. We pay Parcel Post insurance charge when full remittance, including Parcel Post charges is made.

## REPLACEMENT PARTS FOR ALL SETS

Peerless Condenser Bank	\$3.25	Majestic "A" condenser	3.50
Peerless Transformer	3.00	R. C. A. 17 Condenser Block	3.00
Victor Power Transformer	2.50	R. C. A. 17, 18, 33, 51 Transformer	3.00
Majestic Master B. Elm. Cond.	2.75	R. C. A. 44-46 Transformer	3.50
Majestic Super B. Elm. Cond.	2.95	R. C. A. 60-62 Transformer	5.25
Majestic sets using 171 tubes (Cond.)	4.25	R. C. A. 66 Transformer	4.15
Majestic sets using 245 tubes (Cond.)	4.50	A. K. 37 Condenser Block	3.25
Majestic sets using 250 tubes (Cond.)	4.65	A. K. 37 Power Transformer	3.50
Majestic type 90B (Cond.)	4.50	Zenith Z. F. 11 Condenser	5.25
		A. K. 40 Pack complete	9.75

## Flechtheim 1000 VOLT Filter Condensers

Mounted in metal cans. Fork type connectors. Rated at 1000 volt D. C.

HSM5 .05 mfd.	79¢
<b>YOUR PRICE</b>	
HSM10 .1 mfd.	82¢
<b>YOUR PRICE</b>	
HSM25 .25 mfd.	85¢
<b>YOUR PRICE</b>	
HSM50 .50 mfd.	89¢
<b>YOUR PRICE</b>	
HSM100 1.0 mfd.	95¢
<b>YOUR PRICE</b>	
HSM200 2. mfd.	\$1.65
<b>YOUR PRICE</b>	
HSM400 4. mfd.	\$3.15
<b>YOUR PRICE</b>	

**RADIO SURPLUS CORPORATION**  
**56R Vesey Street New York, N. Y.**



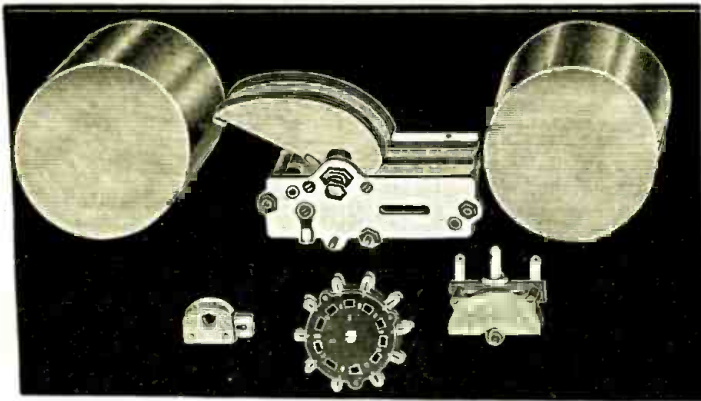

# Switch!

**I**F YOU USE plug-in coils, or contemplate using them, for wide wave coverage, switch over to switching!

A Foundation Unit gives you the convenience of front-panel knob selection of the wave band for tuning in from 15 to 550 meters. Two tuned circuits, but only a single switch. The two-gang condenser has brass plates and is straight frequency line. You know the advantage of shielding in broadcast sets. Enjoy the same advantage in short-wave and all-wave reception. Use cadmium-plated copper shields. The Foundation Unit has them.

The All-Wave Foundation Unit is made in two different models, so as to be applicable to both types of circuits, TRF or Super, whether a.c.-operated or battery-operated.

For the popular circuit comprising one stage of tuned radio frequency amplification and a sensitized detector, the double shield assembly is used (Cat. AWTRF at \$15).

For a converter to be used with a broadcast set, or for any other circuit using the double detector system of reception, the unit has the same appearance as the other but the coil windings differ (Cat. AWSS at \$15).

Full constructional data supplied with the units.

## 175 KC. BAND PASS FILTER TRANSFORMER



**A** DOUBLY TUNED fixed-frequency transformer, 1 to 1 ratio, tuned to 175 kilocycles, but adjustable from 100 to 190 kc., is a precision product. Two loosely coupled duolateral-wound high-inductive choke coils constitute primary and secondary, and afford a flat-tuning characteristic, i.e., band pass filter. Suitable for all uses where high selectivity, without sideband cutting, is desired. The transformer may be mounted on the side of a chassis, in horizontal position, or upright either above or below the chassis top. Tuning condensers are across primary and secondary, both accessible: in aluminum shield (which must be grounded) 2 1/4 inches diameter, 2 1/2 inches high, with removable bottom. For screen grid tubes, Order Cat. FF-175, net price....\$3.00

### 450 KC. TRANSFORMER

Same as above, except that frequency is 450 kc., adjustable from 400 to 550 kc. For screen grid tubes. This intermediate frequency is particularly suitable for short-wave Superheterodynes. Order Cat. FF-450, net price....\$3.00

### OTHER FREQUENCIES

We can make intermediate frequency transformers to order for any frequency, utilizing our band pass filter circuit. State frequency and write for prices.

## FULL BAND SPACE-WOUND COILS

**S**PACE-WOUND tuning coils for shielded circuits, designed with special care to insure identity of inductance and minimum distributed capacity, with assurance of covering the whole broadcast wave band, and more, with .0005 mfd.

With each coil is supplied a drawn aluminum finished shield, 3-inch diameter, 3 1/2 inches high. Copper shield extra.

**ANTENNA COIL** for all circuits, also interstage coil where the primary is in the plate circuit of a general purpose tube. Order Cat. 15-85, net price.....\$2.50

**INTERSTAGE COIL**, where primary is in the plate circuit of a screen grid tube. Order Cat. 25-85, net price.....\$2.50

**OSCILLATOR COIL**, consisting of secondary, fixed flecker and small pickup coil winding, each winding wholly independent of the others. Order Cat. 8-30-85, net price...\$2.75

**COPPER SHIELD**, bracket, Cat. CS-II @ \$1.15 (Copper shield, 3" diam. x 4 1/4" high, with bracket, substituted for aluminum shield above, extra 65c.)

## DYNATRON OSCILLATOR

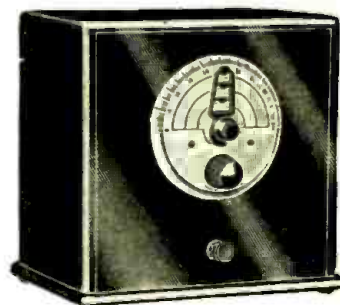

An oscillator for battery operation, using one 232 and one 230 tube. Wave coverage, 15 to 550 meters. The screen grid tube (232) is used as a dynatron oscillator and there is one stage of radio amplification to permit putting a load on the circuit, without stopping oscillation. Cat. DYNO at .....\$12.50 Calibration Charts (4) at... 1.00

Send for our Short-Wave Pamphlet, with Time Table of Short-Wave Stations. Ask for Pamphlet GB.

# ROLAND RADIO CO.

137

Hewes Street

Brooklyn, N. Y.

# \$

# Prices YOU can make a REAL profit on!

# \$

### Famous Model "G" Gordon Phono-Motor and Turntable

First time at this price. Ruggedly constructed throughout. Spanish felt gears assure silence. Equipped with automatic stop control. Induction type, no brushes. Easy to install—exceptionally quick starting torque. For 110 volt 60 cycle alternating current. Proven dependability has made this New Gordon Electric Phonograph Motor and Turntable the accepted standard of excellence for the industry.

First time at this price. Make a nice profit and build good will with everyone.

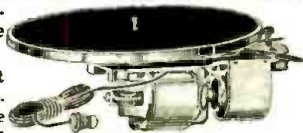

List \$30.00  
**OUR PRICE \$9.95**

### Farrand Dynamic Chassis

Famed for its simplicity and reliability. Easily installed in all types of radio or phonograph consoles. Tonal range and fidelity superior to any other reproducing unit in general use. Dimension: Height 9 inches, width 8 3/4 inches, depth 7 inches. For A.C. current.

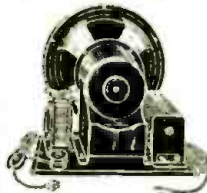

**OUR PRICE \$5.95**

### Condenser Block for Majestic "B" Eliminator



**OUR PRICE \$2.75**

Replacement for defective blocks in "B" Eliminators—identical in electrical characteristics and outside dimensions. Can also be used in any make "B" Eliminator as well as most power packs

### Gordon Acme 4 Pick-Up with Volume Control

Genuine Bakelite arm with beautiful natural wood finish will not show wear as will plated metal. Faithfully reproduces the entire musical range.



**OUR PRICE \$4.50**

**I.C.A. Test Leads**—a necessity to the dealer or serviceman. Unsurpassed for testing sets and tracing shorts, opens and other common defects. Easily attached to testing meter or electrical apparatus. **40c**

### R. C. A. Radiola Magnetic Chassis



Will stand up to 600 volts without distortion. Contains output transformer. Used in 100B. and 103 speakers. Outside diameter 9 in.; depth over all 4 1/2 in. Ideal for any radio installation. Complete with 5 ft. radio cord.

**OUR PRICE \$2.95**

### R. C. A. Loudspeaker 103

A beautiful speaker, superb in its faithful reproduction. Molded frame and pedestal resemble hand carved oak. Mechanism concealed by attractive tapestry.



(Genuine R.C.A.)  
List \$18.00

**OUR PRICE \$4.25**

### Atwater-Kent Condenser & Filter Block

For Model 37 and 38 Sets

Ideal filtering system for ANY make A. C. set using 171-A tube. Contains proper chokes and high voltage condensers. Flexible wire colored leads same as original.

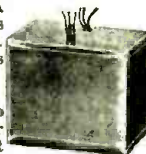

**HOOK-UP**  
Green wire to 280, black to R.F. plate, yellow to Power Tube plate, white to first audio by-pass, white to C.T. of 226 resistance, red to detector plate. Wire from PRICE can to ground.

**\$3.60**

### Kolster K-6 Speaker

Magnetic type cone speaker. Remarkable tone quality; volume to spare. Beautifully curved, fine Walnut cabinet. Equipped with highly sensitive oversize magnet and driving unit. Faithful reproduction from the faintest whisper to fullest volume of a brass band.



List \$20.00  
**OUR PRICE \$3.95**

### AIR-KING

### Superheterodyne S.W. Converter

The greatest converter ever built.

Brings in European stations clear as a bell. Converts any set into a short wave receiver. Employs 3-227 tubes; covers from 20 to 115 meters. Coil switch covers all wave lengths. Single dial control, no body capacity, no squeals. Has built-in filament transformer to heat the 3-227's. All you need from your receiver is a positive B. voltage from 45 to 180 volts. Voltage is not critical; no molestation of the receiver. Size 7x10x5 in. Weight 8 lbs.

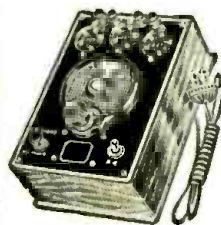

**OUR PRICE \$14.70**

### New Type Elkon Dry Disc Rectifier

Standard on "A" Eliminators for Majestic, Mayolian, Webster, Elkon, Bernard, Pada, Knapp, Sentinel, Metro, General Instrument, Philco (Elkon equipped) and also on Elkon 3 amp., and Briggs & Stratton chargers.

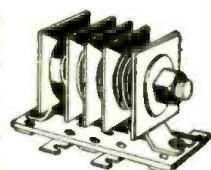

**OUR PRICE**

**\$3.45**

List \$7.00

### Baldwin Rival Unit



This Nathaniel Baldwin unit is one of the finest. For phonograph, automobile and portable radio outfits. We offer this famous unit now at a sensationally reduced price.

**OUR PRICE 65c**

### VICTOR ABC Power Transformer

For use with 6-226, 2-245, 1-227 and 1-280 tubes. Magnetically shielded preventing hum. Can safely be overloaded 30%. High voltages, 400 volts at 150 mils on either side of center tap. Extra large case especially designed to prevent overheating.

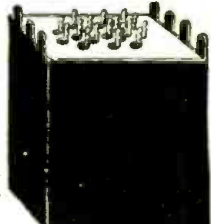

Can Be Used For Any Power Amplifier Using 245 Tubes

Size: 4 1/2 x 5 x 5 1/2 inches.  
No. 1—Center tap of 9 and 14 (5 volts).  
No. 2 and 4—2 1/2 Volts.  
No. 5 and 7—1 in. V. High amp. (226).  
No. 3 and 6—Primary (110V. input).  
No. 8—Center tap of 12 and 17 (2 1/2 V.)  
No. 9 and 14—5 Volts (280).  
No. 10 and 15—High voltage for B supply.  
No. 16—Center tap of above.  
No. 12 and 17—2 1/2 in. volts high amp. (224).

**OUR PRICE \$2.75**

**FREE Catalog—means money to you**

These are only a few samples of the values to be found in our catalog. It is full of items on which you can make from 50% to 300% profit. And the best of them is, they are sound, well known, trademarked articles you can depend upon.

Send 20¢ with the order and articles will be shipped C.O.D. Order any of the above articles direct from this page. And be sure to ask for the catalog. It means money to you!

**RADIO CIRCULAR CO.**

225 Varick St. New York City

## ORDER DIRECT...from this page! TEAR IT OUT NOW!

**RADIO CIRCULAR CO., 225 Varick Street, New York City**

Enclosed find \$..... This is 20% of items listed below. I will pay balance upon receipt of merchandise.

Name.....  
Address.....  
City..... State.....  
 Also please send catalog.

### Send for FREE catalog!

**RADIO CIRCULAR CO.**  
225 Varick Street, New York City

Please send me your catalog of radio bargains I can make a profit on.  
I understand this obligates me in no way.

Name.....  
Address.....  
City..... State.....



# STOP SHOPPING!!

HERE'S A NEW plan, which saves you money. Stop shopping—the lowest prices are right on this page. Yes, lower than in our own catalog. Why? Because no house can get out a new catalog every month, but by advertising in this magazine we can bring

you the latest and lowest prices up to the time this ad is printed. We watch our competitors and do not allow anyone to undersell us. We meet ANY price on NEW merchandise. Order direct from this page and save money. 100% satisfaction on every transaction.

## NEW! NEW!

Several months ago we sent out a questionnaire to 2,000 radio service men and asked them what their ideas were on a radio service kit. 865 answered us, and their ideas are now embodied in the Official Radio Service Kit which we herewith present to you.

This kit is a marvel in compactness, a marvel in price, a marvel in time saving. For the first time you are offered a comprehensive kit that contains EVERYTHING that the service man requires in making calls.

### ARE YOU A 50 PER CENT SERVICE MAN?

Too often so-called service men go on a job with an analyzer and a pair of pliers. Nine times out of ten they have to run back to the shop to get tools, and thus their usefulness is set down, as a rule, 50% and over. Why not take along, on every job, a business-looking like service kit that looks just as business-like as your analyzer?

When you call upon a prospect and you arrive with this fine-looking kit, your prospect knows that you mean business. It gives you a professional appearance that every service man requires more than anything else today.

### AND YOU CAN COMMAND MORE MONEY ON YOUR SERVICE CALLS WITH THIS KIT

because the prospect will look upon you as a professional, and not as a tinkerer.

When you visit a medical specialist today, you are impressed by his instruments, for which you pay. An ordinary doctor commands no such fees. It should be clear to you that if you are a professional, you can get professional prices today too. That is why this marvelous kit will pay for itself inside of three months or less.

Herewith, are the Official Radio Service Kit specifications: Size, small and compact, not larger than a good analyzer; 17 in. long, 6 1/2 in. wide and 10 in. high.

Construction, wood veneer throughout, entirely covered with black leatherette, all nickel trimmings, giving outfit a beautiful professional appearance.

There are two trays which lift out. Top tray contains the following:

## Official Radio Service Kit



**\$15.75**

Both felt lined trays are built to fit the tools and contents of kit. Everything ALWAYS in place. No hunting for this or that item. Neat. Efficient.

- 1 Pen Flashlight, complete with magnifying dentist's mirror (to look underneath chassis, etc.).
- 1 Automatic alcohol blow torch.
- 1 Box containing 500 assorted screws, nuts, washers, lugs, etc.
- 1 Nickel Bicycle wrench.
- 1 Tap holder with one 6/32 tap and one 8/32 tap.
- 1 Set of Test prods, with 6 ft. cord.
- 1 Telephone type pliers.
- 1 Diagonal pliers.
- 1 Insulated (5,000 volt insulated handle) heavy pliers.
- 1 Electrician's knife.
- 1 Set of 8 drill points.
- 10 Ft. of Phosphor bronze drain dial cable.
- 1 Neutralizing socket.
- 1 Pack extra size pipe cleaners (to clean condensers).
- 3 Small screw drivers.

- Lower tray contains:
- 1 Complete Neutralizing kit with insulated screw driver and five socket wrenches.
  - 1 Electric soldering iron, with 1 extra tip.
  - 1 Large and 1 Medium imported screw drivers.
  - 2 Small files with handles.
  - 1 Large file with handle.
  - 1 1/4 in. Star drill, 1 1/4 in. long.
  - 1 Hand drill, 1/2 in. chuck, 10 in. long.
  - 1 Electrician's metal hammer.
  - 1 Hack saw and blade.
  - 1 Package Sani papers and emery papers.
  - 1 Roll 50 ft. solid push back wire.
  - 1 Can genuine Kester radio solder.
  - 1/2 lb. of 3/4 in. electrician's tape.
  - 1 Bottle Furniture polish.
  - 1 Package Furniture cheese-cloth.
  - 1 Bottle Nujol (for lubricating purposes).
  - 1 Tube special cement (to mend cones, etc.)
  - 1 Socket tool to straighten socket prongs.

## NEW! NEW!

### IMPORTANT!

There is sufficient room in the bottom of the kit to place the Official Radio Service Manual, as well as other data sheets (but at the price quoted Manual is not included).

Both trays, as well as inside cover, are lined with blue felt, giving kit a beautiful appearance.

Nothing similar has ever been offered before. Only by buying the various materials in tremendous quantities are we enabled to sell this kit at such an extremely low price.

If you were to buy all of the articles separately, in the open market, you would have to pay between \$30.00 and \$35.00 for them.

Due to the present depression, we are enabled to buy quantities of these materials at exceedingly low prices. For that reason, our production cost is exceedingly low, but there is no question that this price will have to be increased later.

Size, 17 in. long, 6 1/2 in. wide and 10 in. high; net weight, 16 lbs.; shipping weight, 18 lbs.

No. 1000—Official Radio Service Kit—Your price..... **\$15.75**

### CARRYING CASE

We are prepared to furnish you with the Official Radio Service Case only, without contents, as described above, just the case and the two empty trays, size 17 in. long, 6 1/2 in. wide and 10 in. high.

This case is made entirely of light veneered wood, nickel trimmings, covered entirely with leatherette. Inside of case covered in blue felt.

Net weight, 4 lbs. Shipping weight, 5 lbs.

No. 1001—Official Radio Service Carrying Case only, your price **\$4.85**

View of kit, closed.

### RADIO CARRYING CASES

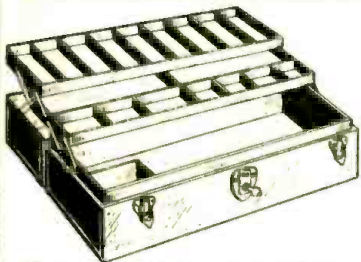

The cases here shown are a new development. They are made in metal throughout with baked olive green enamel finish. These cases are beautifully and strongly made, and will give you a professional appearance. Lock and side locks are of burnished brass.

The smaller illustration shows dimensions and closed view of the cases. As you open the cover, two trays automatically fold out in position, as shown. As you tilt the cover back, the trays fold automatically into the case. The trays are provided with a number of compartments for tools and all other radio appliances that you may wish to carry. The large box accommodates about eight radio tubes in the bottom compartment. The smaller case accommodates about four tubes.

Cases are strong and rugged, and when closed, nothing can spill. They are marvels of ingenuity, and will pay for themselves many times over.

Large size measures 2 1/2 in. high, 7 1/2 in. wide. Net weight 8 lbs. Shipping weight, 10 lbs. List price \$8.50. No. 1002—Carrying Case. Your price **\$4.75**

### SMALL CARRYING CASE

This case is in all respects the same as the one described above, except that the dimensions are less, otherwise the same in all respects.

Size 12 1/2 in. long, 7 1/4 in. high and 7 in. wide. Net weight, 5 lbs.; shipping weight, 6 lbs. List price, \$6.50. No. 1003—Carrying Case—Your Price **\$3.45**

## NEW! NEW!! Superheterodyne S-W Converter

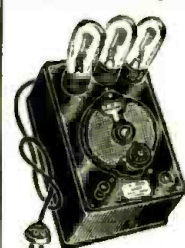

At last a short-wave converter that converts any broadcast set into a superheterodyne short-wave receiver. Employs three 227 tubes and covers from 20 to 115 meters. No plug-in coils! Coll switch is used to cover all wavelengths. Single dial control, no body capacity, no squeals. This converter has built-in filament transformer to heat the three 227's.

All you need to obtain from your receiver is a positive B voltage anywhere from 45 to 180 volts. Voltage is not critical; no modulation of the receiver. So simple a child can operate it. Size 7 x 10 x 5 inches. Shipping weight, 8 lbs. List Price \$25.00.

No. 1614—Super Converter (less tubes). YOUR PRICE..... **\$14.69**

## World-Wide Short-Wave Set NOT A CONVERTER

A perfect radio short-wave receiver for use between 17 and 81 meters. To put into operation, connect antenna, 20 to 40 ft., 45-volt "B," and 6-volt "A" batteries, and headphones to the jacks provided, plug in a type "01A" tube, and tune in! An ingenious circuit makes possible a 4-coil single-winding plug-in design. This little instrument has the same sensitivity as many big, six-timed short-wave receivers costing ten times as much. A power amplifier may be added for any degree of volume. Complete with 4 plug-in coils. Has fine vernier dial for precision tuning. Never has a first class short-wave set sold for so little money. This short-wave set measures 5 1/2 x 7 1/2 in. high, over all. Ship. weight, 3 lbs. List price, \$12.50.

No. 1666—World-Wide S.-W. Set. **\$6.25** Your price.....

## New 36 page Summer Edition No. 23



The new Summer Edition of our greatly enlarged RADIO SERVICE TREATISE has just come off the press. If you liked the Winter Issue, you will like this one a hundred-fold. It contains some 75 new hook-ups, circuit diagrams; and some 350 illustrations. POSITIVELY THE GREATEST BOOK EVER PUT OUT BY ANYONE. Among the new matters listed are:

VACUUM TUBE TREATISE, with many illustrations; full page Vacuum Tube Average Characteristics Chart; How to Take Care of Your Tubes; How to Connect Phonograph Pick-ups; Improving the Tone Quality of Old Sets; Connecting Additional Loud Speakers; all fully illustrated with diagrams.

Other articles: Modernizing Old Radio Sets; How to Convert Battery to Power Sets; Selection of Tubes; Push-Pull Amplifiers; Replacing Audio Transformers; Phono Attachments; How to Choose Power Transformers; Voltage Dividers; Warnings of Power Transformers; Selecting and Installing Replacement Parts in Radio Sets; Filter Condensers; Repairing Eliminators.

WRITE TODAY. Enclose 2 cents for postage. Treatise sent by return mail.

75 New Hook-Ups, etc. 350 Illustrations.

## THORDARSON "245" Power Transformer

A Miniature Power Plant — Supplies All ABC Voltages — 80 Watts

In addition to supplying a full 250 volts to the plates and 50 volts to the grids of two type "6X5" tubes in push-pull, this transformer may be used to light the filaments of seven or eight 2.5-volt filament tubes; and by connecting in series two of the three 2.5-volt filament secondaries it is possible to light 5-volt filaments too. Five secondaries: S1—5 V., 2 Amp.; S2—310 V. Cent. T.; S3—245 V., 3 Amp. Cent. T.; S4—245 V., 10 1/2 Amp.; S5—245 V., 3 Amp. Cent. T. Just the power transformer for building up a high-grade public address amplifier to use a screen-grid A.F. amplifier to boost the output of a microphone or phonograph pick-up; following this with two stages of push-pull amplification consisting of two "27" in the first stage and two "45" in the second. Bottom of transformer has bakelite panel on which are mounted all taps. It outperforms ANY similar transformer. Many Service Men keep this model transformer on hand for emergency replacements in hundreds of makes of radio sets. For 110-120 volts, 50-60 cycles. Size: 5 in. high x 4 x 3 1/2 in. Shipping weight, 8 lbs. List Price, \$15.00.

No. 1450—Thordarson Power Transformer. YOUR PRICE..... **\$3.84**

No. 1450—Thordarson Power Transformer. YOUR PRICE..... **\$3.84**

## High-Voltage Condenser Units

We guarantee these condensers unconditionally. They are ideal for general replacement purposes and can be installed in any new power-pack. All condensers are furnished with 8-inch lengths of tuned "push-back" wire.

600 VOLTS			800 VOLTS		
Cat. No.	Mfd. Capac.	Your Price	Cat. No.	Mfd. Capac.	Your Price
1702	1/2	\$0.25	1706	1	\$0.40
1703	1	.30	1707	2	.70
1704	2	.40	1708	4	1.05
1705	4	.60			

WE ARE A WHOLESALE HOUSE AND CANNOT ACCEPT ORDERS FOR LESS THAN \$3.00. If C. O. D. shipment is desired, please remit 20% remittance, which must accompany all orders. If full cash accompanies order, deduct 2% discount. Send money order—certified check—U. S. stamps.

**Radio Trading Co.**  
23 West Broadway  
New York, N. Y.

ORDER FROM THIS PAGE. You will find special prices from time to time in this magazine. Get our big FREE catalog for the greatest Radio Bargains. Should you wish goods shipped by parcel post, be sure to include sufficient extra remittance for same. Any excess will be refunded.



**Pilot Achieves Radio's Greatest Sensation!**

*The Entire World of Radio*  
**ON A SINGLE KNOB**  
*15 TO 650 METERS* *NO COILS TO CHANGE*  
*The New*  
**PILOT**  
**UNIVERSAL SUPER WASP RECEIVER**

Partly assembled "Universal" for the man who likes to "roll his own". With walnut cabinet, less tubes and speaker.

**85<sup>00</sup>**



Pilot's wonderful wave band changing switch, incorporated in the new Universal Super-Wasp, revolutionizes the short wave art. No longer need numerous coils be changed to cover the various wave bands. No longer need dial settings change each time the same distant stations are tuned in. You can log permanently all the stations you can get throughout the world, you can tune from the short waves to the high ship waves without removing your hand from the single control knob.

**Universal Features Revolutionizing the Short Wave Art**

Complete coverage all wave bands from 15 to 650 meters *without coil changing*. Complete A.C. operated *chassis in cabinet*. (Also available in battery model) . . . All Metal Chassis

. . . Highly sensitive and selective circuit . . . Screen Grid TRF amplifier *plus* Screen Grid *Detector* . . . 227 First Audio Stage . . . Two 245's in push-pull output stage . . . Stations can be logged *permanently on dial* . . . Regeneration control does not alter tuning . . . Provision for *Phonograph Pick-up* . . . Earphone Jack on *Front Panel* . . . Illuminated Dials . . . Handsome Walnut Cabinet . . . Most advanced construction yet used for short wave work . . . In kit form for easy home assembly; no drilling or cutting, all parts fully prepared.

NOTICE TO "HAMS": Pilot will continue building the original Super-Wasp in kit form for licensed amateurs and others who want to spread the tuning on their pet wave bands and add their own audio features. A.C. and battery models.

**PILOT RADIO & TUBE CORP., Lawrence, Mass.**



Chicago: 234 S. Wells St.

New York: 525 Broadway

San Francisco: 1278 Mission Street

OFFICES IN PRINCIPAL COUNTRIES OF THE WORLD



# SM

## 10 TO 550 METERS WITHOUT PLUG-IN COILS

### 726SW All-Wave Superhet

In the 726SW there is available for the first time a combination of the very latest and most modern superheterodyne broadcast and short-wave designs on one chassis. Logically, it is the product of McMurdo Silver and the Silver-Marshall laboratories—foremost superheterodyne designers in America.

### Nine-Tube Vario-Mu Broadcast Super

In the 200 to 550 meter band, the 726SW is a nine-tube vario-mu pentode superhet employing nine tuned circuits. One precedes the '51 r.f. stage, a second is before the '24 first detector, and another with the '27 oscillator. The two tuned circuits ahead of the first detector, coupled with the '51 vario-mu tube, absolutely eliminate all cross-talk or image frequency interference. The two-stage i.f. amplifier, using '51 tubes, has a total of six tuned circuits (three siamese, or dual tuned transformers) which definitely assures uniform and absolute 10 kc. selectivity at short or long waves.

### Pentode Tubes in Push-Pull

A '27 second linear power detector feeds a compensated push-pull '47 pentode audio stage delivering from 5 to 7 watts undistorted power output, and in turn feeds a specially compensated electro-dynamic speaker unit.

### 60 to 100 Broadcast Programs

The broadcast sensitivity ranges from less than one-half to seven-tenths of one microvolt per meter—so great that every station above the noise level can be tuned in easily. The selectivity is absolute 10 kc., and in any large city distant stations on channels adjacent to locals can be readily tuned in. From 60 to 100 different stations can be logged almost any night in any fair location.

### Eleven-Tube Short-Wave Super

The short-wave end of the 726SW is the dream of old—a true eleven-tube superhet using "double-suping" on not one, but

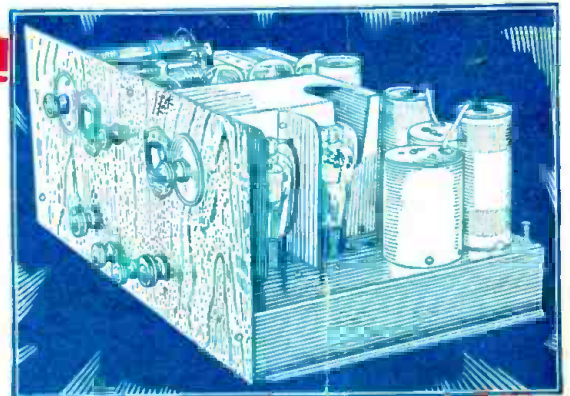

two, intermediate frequencies. Yet it has but one dial—plus a non-critical trimmer! For short-waves, a '24 first detector and '27 oscillator ganged together are added by a turn of a switch, which selects between short-wave and broadcast band reception. A second selector switch chooses between four ranges (from 10 to 200 meters) at will—and all without a single plug-in coil.

### Thousands of Miles of S-W Range

The sensitivity, selectivity on short-waves are exactly equal to the broadcast band—giving thousands of miles of range.

Tubes required: 2—'24's, 3—'27's, 3—'51's, 2—'47's, 1—'80.

726SW All-Wave Superheterodyne, complete as described above, wired, tested, licensed, including S-M 855 electro-dynamic speaker unit. Size 20½" long, 12" deep, 8½" high. To be used on 110-120 volt, 50-60 cycle AC power. Price \$139.50 LIST.

## Write for *New* General Parts Catalog

SILVER-MARSHALL, Inc. Dept. R-C 2  
6419 W. 65th Street, Chicago, U. S. A.

Please send me full details on the S-M 726 SW (enclosed you will find 2c).

Please send me FREE your new General Parts Catalog.

Name \_\_\_\_\_

Address \_\_\_\_\_

The new Catalog gives detailed data on a complete new line of chassis, kits, amplifiers, replacement parts, etc. Everything from a short-wave converter without plug-in coils, to a new line of transformers.

**SILVER-MARSHALL, Inc.**  
6419 West 65th Street • Chicago, U. S. A.

Canadian Division: SILVER-MARSHALL of CANADA, Ltd.  
75 Sherbourne Street, Toronto